

CAVA

Touchscreen Fume Hood Controller



TABLE OF CONTENTS

INTRODUCTION1

- General1
- Product Overview.....1
- Features1
- Installation & Service.....1
- Technical Specifications2

MECHANICAL INSTALLATION3

- Mounting Options3

ELECTRICAL INSTALLATION4

- Wiring4
- Room Information Network (RIN).....5
- Controller Area Network (CANbus)6
- BACnet MS/TP Network7
- Network Architecture Summary8

FUME HOOD ACCESSORIES.....9

- Fume Hood Valve Module (FVM) - Venturi Valve (VV) Applications9
- Fume Hood Valve Module (FVM) - Venturi FX Valve (VFX) and Terminal Unit (TU) Applications11
- Sash Position Sensor (SPS)13
- Sidewall Velocity Sensor (SVS).....15
- Fume Hood Presence Sensor (FPS)18

INTERFACE.....19

- Home Screen19
- Configurable Fume Hood Modes20
- Settings21

MAINTENANCE22

- Troubleshooting22
- Replacement Parts.....23
- Technical Support.....23

APPENDIX A24

- Cava™ Jigsaw Cut-Out24
- Cava™ Circular Cut-Out.....24
- Fume Hood Presence Sensor24

INTRODUCTION

General

In this manual, you will find:

- Cava™ technical specifications
- Cava™ mechanical and electrical installation
- Fume hood accessories
- Cava™ interface navigation and configuration
- Troubleshooting information

Please refer to the project specifications, mechanical and electrical plans, and the Antec Controls project submittal documents for project-specific wiring and configuration details.

Product Overview

Cava™ is an exceptionally versatile fume hood controller that precisely monitors and controls fume hood face velocity. Designed specifically to meet the needs of all fume hood types, Cava™ provides assurance that required fume hood face velocity is satisfied and the work environment is safe, while eliminating unnecessary energy usage. Cava™ delivers effective control using Venturi Valves, Venturi FX Valves, or terminal units on fume hoods and biosafety cabinets. Cava™ is intended for continuous, 24-hour fume hood face velocity control and monitoring, and will automatically resume upon restart after losing power.

Cava™ displays critical fume hood details through its interface, where users can effortlessly view real-time information and update a variety of display parameters. Fume hood status is clearly indicated through a colored display with an excellent viewing angle, along with programmable audible alarms ensuring the safety of all users through immediate notification of changes in fume hood status. Cava™ has two physical buttons, including one that allows users to quickly enter emergency mode without having to remove any protective wear.

Features

- 4.3 in. (109.2 mm) capacitive touchscreen display
- Large tactile buttons for 'glove-handed' use
- Audible and visual configurable alarms
- Works with Venturi Valves, Venturi FX Valves, and terminal units
- Sash position sensing, sidewall face velocity sensing, or hybrid sensing configuration
- Controller Area Network (CAN) for communication between fume hood-level devices
- High-speed Room Information Network (RIN) for communication between all room level and fume hood controllers
- BACnet MS/TP
- Fast, intuitive start-up and balancing software
- User defined fume hood modes
- Commissioning port at every Cava™ that allows for simple fume hood and room level setup

Installation & Service

1. A qualified person must perform installation and electrical wiring in accordance with all applicable codes and standards, including fire-rated construction practices.
2. Do not damage electrical wiring and other hidden utilities while installing this device.
3. Disconnect power at the service panel before performing wiring or maintenance on this device.
4. Intended for indoor installation only, in areas with Pollution Degree 3.
5. Not designed for use in industrial, farming, or humid environments.
6. Not designed for use in residential environments and may not have adequate protection to radio interference.
7. Not designed to operate in a construction environment. Use in these environments may lead to excess or unintended wear, reducing product life and/or performance.
8. The manufacturer assumes no responsibility for personal injury or property damage resulting from improper handling, installation, service or operation of the product.



This mark indicates an important point for the proper function of Cava™ and any of its accessories. Pay close attention to all caution points throughout this manual.

For support and in-depth training on this product and other associated system components, please contact your local Antec Controls Representative.

For more information visit www.AntecControls.com



Technical Specifications

Environmental (Operating)	32°F to 130°F (0°C to 55°C), 5% to 95% R.H. (Non-Condensing)	
Environmental (Storage)	-22°F to 158°F (-30°C to 70°C), 0% to 95% R.H. (Non-Condensing)	
Input Power	24 VAC \pm 10%, 50/60 Hz, 12 VA Max (excluding external loads), Class 2	
Inputs		Binary Input (Contact Closure or Active)
	4 Universal Inputs	Analog Input (0 – 10 VDC)
		Resistance Input – Sash Position (0 – 50 k Ω)
		CANbus Room Information Network
Outputs	2 Binary Outputs (Max: 24 VAC, 500 mA)	
Indicators	Touchscreen Display, 4.3 in. (109.22 mm) TFT	
Housing	UL 94V-0, PC-ABS Plastic	
Communication Protocol	BACnet	
BACnet	Device Type	B-AAC
	Communication Type	MS/TP (RS-485)
	Communication Speed	9600, 19200, 38400, 76800 Baud Rate
	Certification	BTL
	Control Priority Order	1. BACnet 2. Normal operation

NOTE: Technical specifications for the Sidewall Velocity Sensor, Sash Position Sensor, Pressure Sensors, and Fume Hood Valve Module can be found in their respective Product Submittals at AntecControls.com.

MECHANICAL INSTALLATION

It is recommended to mount Cava™ at approximately 5½ to 6 feet (1.67 to 1.82 metres) from the floor. This will allow the interface to be at an appropriate height for use during setup and during normal operation.

Mounting Options

Cava™ can be mounted in one of three ways. Option A uses a pre-cut single gang junction box cut-out. Option B uses an on-site created cut-out using a Jigsaw. Option C uses an on-site created circular cut-out.

CAUTION ▼

There are often disconnect switches and gas/water lines running in the fume hood. Make sure that the marked location for the interface does not conflict with any of the other components that may be installed on/in the fume hood. When cutting and drilling holes in the fume hood, ensure proper precautions are taken to avoid scuffing or scratching the fume hood.

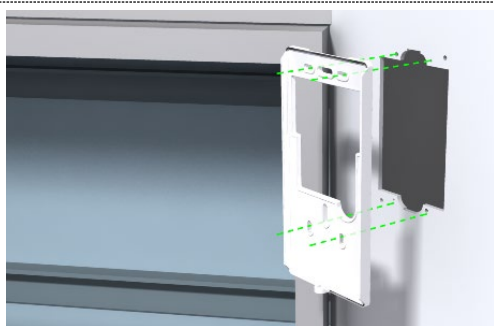

Option A

Mount Cava™ using a pre-cut single gang junction box cut-out.

STEP 1

Mount the backplate to the fume hood using four #6 self-tapping metal screws (minimum 3/8 in. (9.5 mm) long).

STEP 2

Attach Cava™ and tighten the set screw once electrical installation is complete.

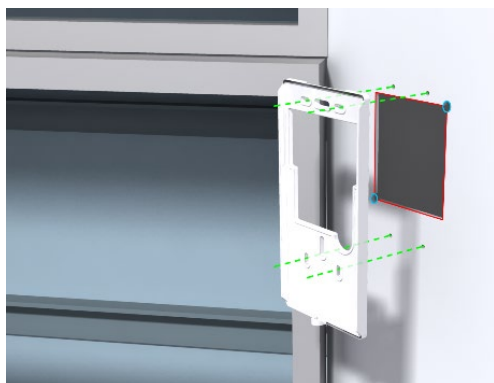

Option B

Mount Cava™ using a Jigsaw cut-out.

STEP 1

Mark the appropriate mounting location for Cava™.

STEP 2

Drill two 1/4 in. to 1/2 in. (6.4 to 12.7 mm) pilot holes at either corner of the provided template in [Appendix A](#).

STEP 3

Using a jigsaw, cut four lines to cut-out a square.

STEP 4

Drill four 7/64 in. (2.8 mm) mounting holes according to the provided template in [Appendix A](#).

STEP 5

Deburr and file any sharp edges if they are present to prevent any edges from cutting the wiring.

STEP 6

Mount the backplate to the fume hood using four #6 self-tapping metal screws (minimum 3/8 in. (9.5 mm) long).

STEP 7

Attach Cava™ and tighten the set screw once electrical installation is complete.

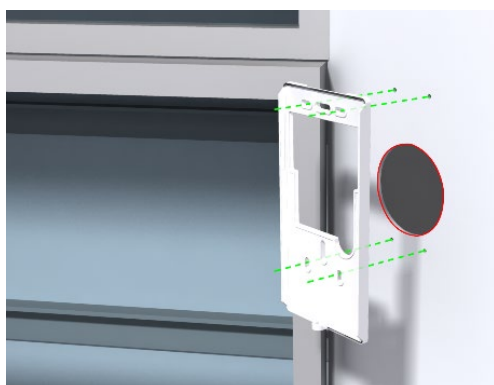

Option C

Mount Cava™ using a circular cut-out. This is the least preferable mounting option, as the hole provides the least access to the wiring terminals.

STEP 1

Mark the appropriate mounting location for Cava™.

STEP 2

Drill a 2.25 in. (57.2 mm) hole in the front panel of the fume hood according to the provided template in [Appendix A](#).

STEP 3

Drill four 7/64 in. (2.8 mm) mounting holes according to the provided template in [Appendix A](#).

STEP 4

Deburr and file any sharp edges if they are present to prevent any edges from cutting the wiring.

STEP 5

Mount the backplate to the fume hood using four #6 self-tapping metal screws (minimum 3/8 in. (114.3 mm) long).

STEP 6

Attach Cava™ and tighten the set screw once electrical installation is complete.

ELECTRICAL INSTALLATION

Wiring

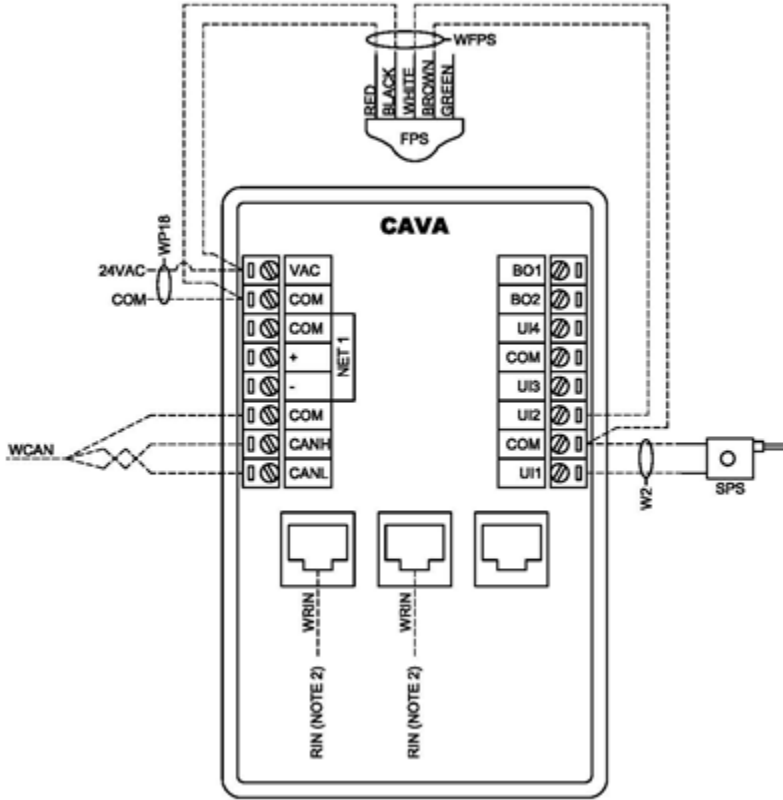

NOTES:

1. For Typical Network Wiring Diagrams, see [Room Information Network \(RIN\)](#), [Controller Area Network \(CAN\)](#), and [BACnet MS/TP Network](#) sections.
2. All wire connections to the Cava™ screw connection terminals must be between 16-26 AWG wire.
3. Current and voltage drop should be taken into consideration when selecting wire gauge.
4. Wiring above may not reflect those required for your project. Refer to your Antec Controls Wiring Diagram Package for typical wiring recommendations.

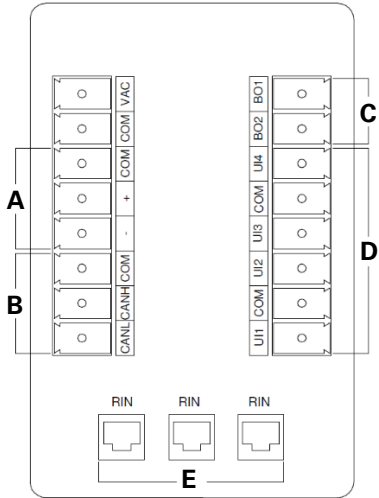

Input / Output Usage

- A** Cava™ has native BACnet capabilities, with the connection being made through the NET 1 terminals.
- B** Cava™ can connect to the Fume Hood Valve Module (FVM) and the Sidewall Velocity Sensor (SVS) through the Controller Area Network (CAN) terminals.
- C** Cava™ can provide a switchable ground binary signal based on a variety of variables and inputs.
NOTE: The high side of the device should be connected to a 24VAC supply, and the common of the device should be connected to a Binary Output terminal.
- D** Cava™ includes Universal Inputs that can be any of the following:
 - Binary Input (Contact Closure or Active)
 - Analog Input (0 to 10 VDC)
 - Resistance Input (0-50 kΩ)
 Universal Inputs are generally used to connect Sash Position Sensors (SPS) or Fume Hood Presence Sensors (FPS).
- E** The Ethernet Ports can be used to connect Cava™ to other room devices through the Room Information Network (RIN) and used for setup or service.

Room Information Network (RIN)

What is the Room Information Network?

The Antec Controls Pace™ and Cava™ operate on an independent high-speed room level network called the Room Information Network (RIN). Together, the Pace™ controllers operating in the room will work to control room level functions such as temperature control, room occupancy, and room pressurization. When used with Cava™, the fume hood flows, face velocities and status will be reported to the room level controllers to ensure all room demands for safety are being met.

Antec Toolbox also uses RIN for room level and fume hood configuration. The user will connect to RIN to communicate with each Pace™ and Cava™ to configure their functionality.

Network Addressing

All Cava™ devices will come from the factory with predefined MAC addresses. If a Fume Hood Valve Module (FVM) is connected during Cava™ setup, the device will populate with a unique name based on the valve tag in the FVM’s linestring. If no FVM is connected, or a different naming convention is required, the name is customizable from the settings menu.

Physical Connection

RIN consists of a 4-wire network architecture (RX-, RX+, TX-, TX+) using a daisy-chain connection between each device on the network segment. A RIN segment has a limit of:

- 12 total RIN devices (Pace™ and Cava™)
- A maximum length of 150 feet (45 meters) between each device.

Users will require an Ethernet Port or a USB-A to Ethernet dongle to connect a laptop to RIN for configuration.

Wiring Requirements

Refer to your Antec Controls Wiring Diagram Package for typical wiring requirements and recommendations.

Typical RIN Wiring

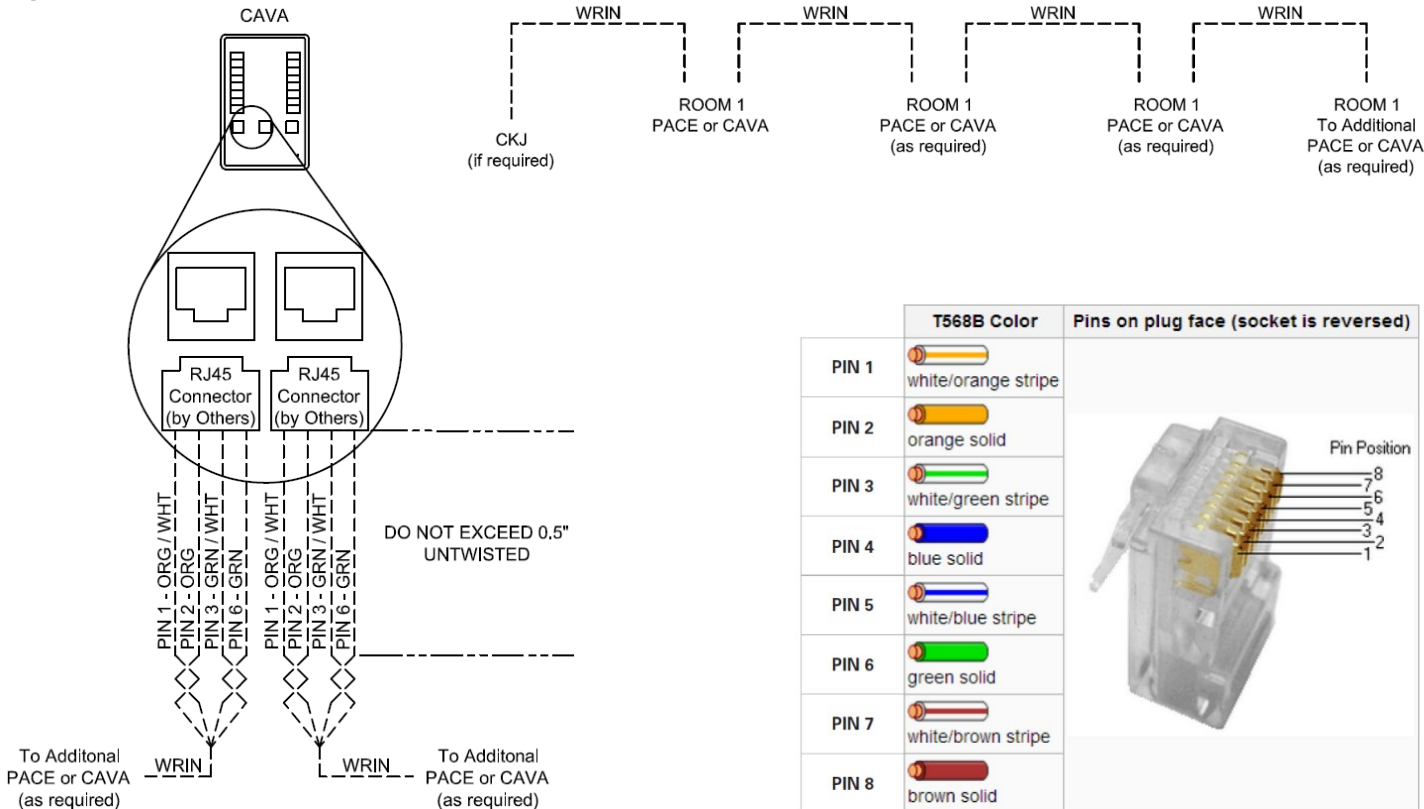

Controller Area Network (CANbus)

What is the Controller Area Network?

The Controller Area Network (CANbus) is a communication protocol that allows the Fume Hood Valve Module (FVM) and the Sidewall Velocity Sensor (SVS) to communicate with Cava™. By transmitting data from the SVS to Cava™ at high speeds and relaying changes to the FVM, Cava™ can ensure that the fume hood is always in safe operating conditions.

Network Addressing

CANbus devices will come from the factory with predefined MAC addresses. No addressing on-site is required.



Power polarity is critical to CANbus communication. To prevent hardware damage, ensure a Class 2 power supply is used and that power polarity is consistent between all CAVA, FVM, and SVS on the same CANbus network.

Typical CAN Wiring

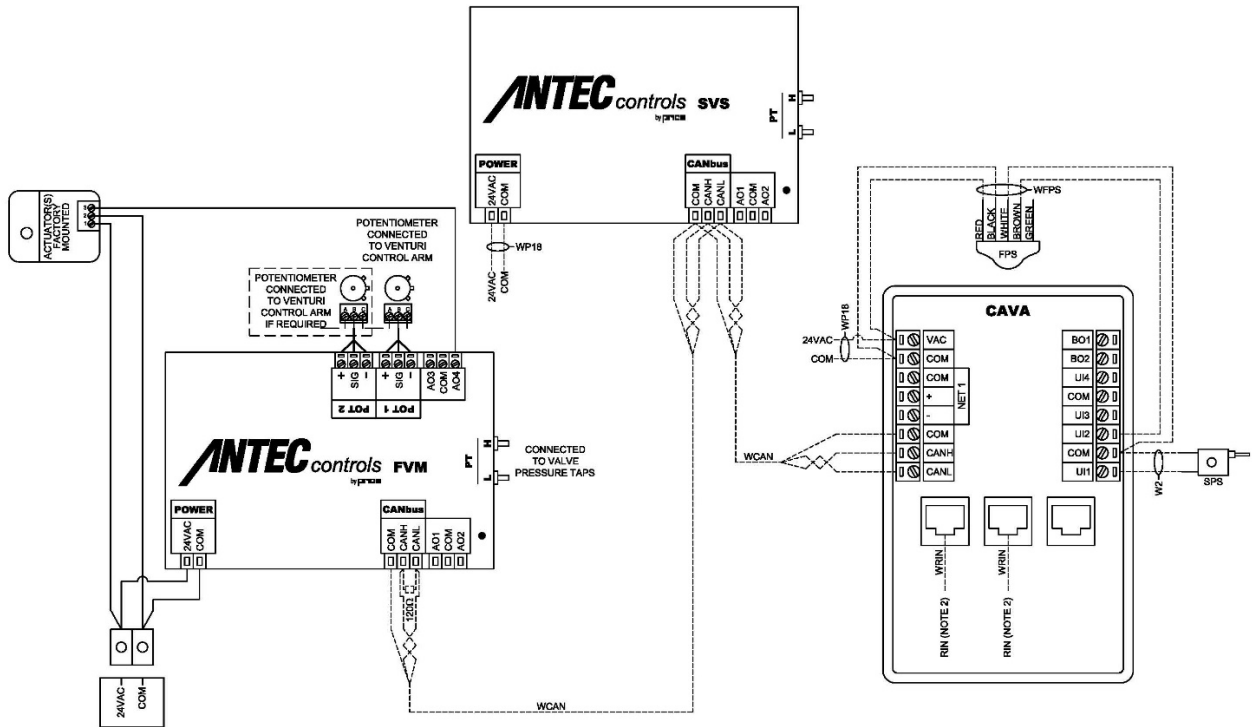

NOTE: Installer must use a 120-ohm resistor at the CANbus end of line termination.

Physical Connection

CANbus consists of a 3-wire network architecture. Daisy chain the CANH, CANL, and COM connections of all devices on the network as shown below. A CANbus segment has a limit of:

- 3 Sidewall Velocity Sensors (SVS)
- 1 Fume Hood Valve Module (FVM)
- A maximum length of 650 feet (200 meters) for the whole segment

When using shielded cable, ground the shield at one end of the network segment only. Connect the shield of the cable entering a device to that of the cable exiting the device.

Terminate the network at the end of line CANbus device by connecting a 120-ohm resistor between the CANH and CANL network terminals. The network may fail to function without the 120-ohm resistors in place. Remove the termination resistor when adding devices to an existing network and re-install it on the new end of line device.

NOTE: Cava™ has a built-in end of line resistor for CANbus and must be an end of line device.

Wiring Requirements

Refer to your Antec Controls Wiring Diagram Package for typical wiring requirements and recommendations.

BACnet MS/TP Network

NOTE: BACnet is only used on Cava™ when it does not have a RIN connection to a Pace™ controller in the room.

What is BACnet?

BACnet MS/TP is a communication protocol for communication between Cava™ and the building automation network. BACnet communication allows the end user to verify rooms and fume hoods are operating as expected and allows them to set up trends to monitor safety, and any alarms that occur.

If no Pace™ controllers are present in the space, a single Cava™ in the room can act as the access point to BACnet. All the fume hood’s information transmits through this one Cava™ to the network.

Network Addressing

When configuring Cava™, the user needs to assign the unique identifying address for the room.

On any BACnet MS/TP network:

- MAC Address can be between 0 and 127 and must be unique to the MS/TP segment.
- Device Instance can be between 0 and 4,194,303 and must be unique to the facility.
- Baud Rate can be 9,600, 19,200, 38,400, or 76,800 and must match that of the Router/System Controller for the MS/TP segment.

Typical BACnet Wiring

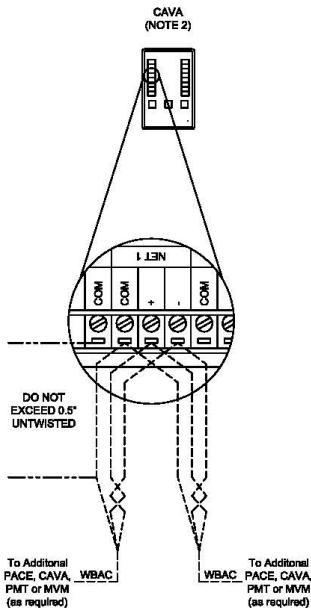

BACnet Points

See Cava™ Product Submittal at AntecControls.com for BACnet Points List.

Physical Connection

BACnet consists of a 3-wire network architecture. Daisy chain the +, -, and COM connections of all devices on the network segment. A BACnet MS/TP segment has a limit of:

- Maximum of 32 devices
- Maximum length of 1050 feet (320 meters) for the whole segment

When using shielded cable, ground the shield at one end of the network segment only. Connect the shield of the cable entering a device to that of the cable exiting the device.

Terminate the MS/TP network segment at each end of the network segment by connecting a 120-ohm resistor between the + and – terminals. Remove the termination resistor or disable any network terminations on all devices when adding devices to an existing network segment.

Wiring Requirements

Refer to your Antec Controls Wiring Diagram Package for typical wiring requirements and recommendations.



When using non-isolated power supplies (i.e. Transformer secondary common connected to ground), do not reverse 24VAC polarity on any device, as it is critical to the network health.

NOTE: Installer must use a 120-ohm resistor at the BACnet end of line termination.

Network Architecture Summary

See the information outlined in the example below for a summary of the network architecture of Cava™.

Typical Laboratory Wiring

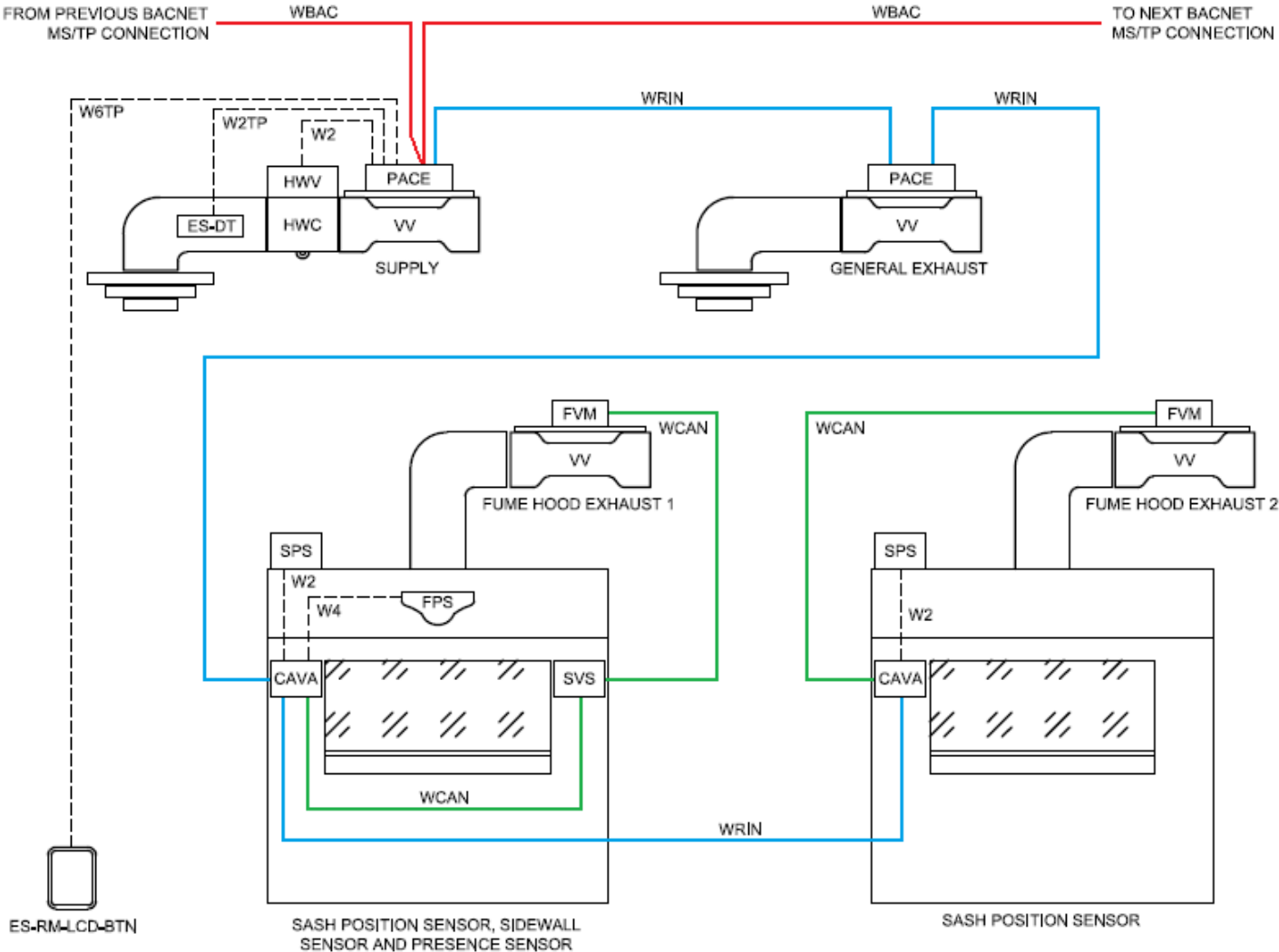

Line Color	Network Type	Considerations
Blue	Room Information Network (RIN)	Up to 12 controllers (PACE and CAVA combined) Daisy chained network wiring between each device on the network NOTE: A connection through a RIN access point is used to start-up and commission the system. An Ethernet Port on the back of any CAVA can act as this access point.
Green	Controller Area Network (CAN)	Maximum of 3 Sidewall Velocity Sensors (SVS) Maximum of 1 Fume Hood Valve Module (FVM) Daisy chained network wiring between each device on the network
Red	BACnet MS/TP	Recommended up to 32 devices (including CAVA, PACE, PMT, MVM, or 3rd party) One BACnet network is allowed per RIN Daisy chained MS/TP segment only connects through one PACE (or CAVA if no PACE is present) controller per room

FUME HOOD ACCESSORIES

Cava™ can take advantage of multiple fume hood accessories to effectively monitor and control fume hood face velocity, reduce energy consumption and keep work environments safe.

Fume hood accessories provided by Antec Controls include:

1. Fume Hood Valve Module (FVM) - Venturi Valve (VV) Applications
2. Fume Hood Valve Module (FVM) - Venturi FX Valve (VFX) and Terminal Unit (TU) Applications
3. Sash Position Sensor (SPS)
4. Sidewall Velocity Sensor (SVS)
5. Fume Hood Presence Sensor (FPS)



Different types of fume hood accessories can be used with Cava™. When using accessories by Others, ensure that the output from or input to the device meets the requirements of the inputs and outputs on Cava™ which can be found on [Page 1](#).

Fume Hood Valve Module (FVM) - Venturi Valve (VV) Applications

The Fume Hood Valve Module (FVM) works directly with Cava™ to accurately meet the target exhaust airflow and fume hood face velocity. The FVM used in Venturi Valve applications uses calibrated position feedback to provide accurate airflow through the valve and provides real-time differential pressure readings to ensure the valve remains within its operating parameters at all times. The FVM delivers this real-time airflow device information to Cava™ for display and communication over CANbus.



See the FVM product submittal on AntecControls.com for Specifications, Dimensions and Wiring.

Mechanical Installation

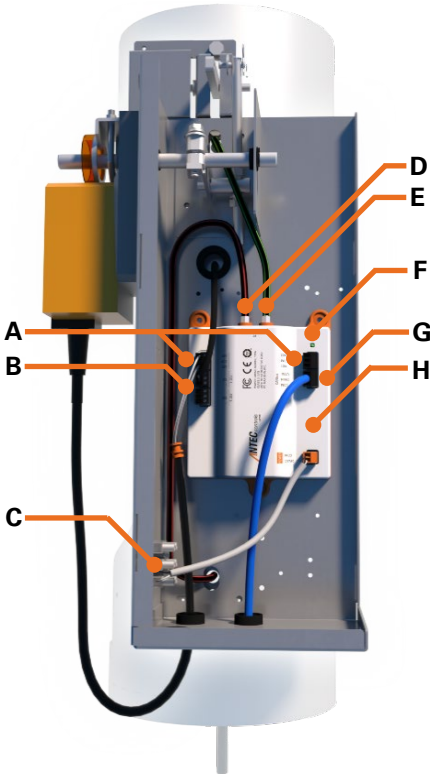

Overview

The FVM is factory calibrated and mounted on the valve with which it was ordered. Only electrical installation is required. Open the controls enclosure on the valve and follow the wiring diagram in the project submittals for electrical installation.

Components

- A** 4 Analog Outputs (0 to 10 VDC, 10 mA Max. Each connected actuator requires 1 output)
- B** 2 Potentiometer terminals (unique to Venturi Valve applications)
- C** Terminal Block to be connected to 24VAC power source (50/60 Hz, 17 VA Max)
- D** High-pressure port
- E** Low-pressure port
- F** Indicator LED
- G** CANbus terminal for connection to CAVA and other CANbus devices
- H** Fume Hood Valve Module (FVM) pre-installed in fume hood valve enclosure

NOTE: The FVM is factory mounted within the enclosure using #8 x 5/16 in. (7.9 mm) screws through three mounting holes.

NOTE: The maximum torque rating for any bushings on the enclosure is 4.43 in-lbs (0.5 N-m).

Electrical Installation

CAUTION ▼

POT1 and POT2 terminations

Wire Color	FVM Terminal
Red	+
Green	SIG
Black	-

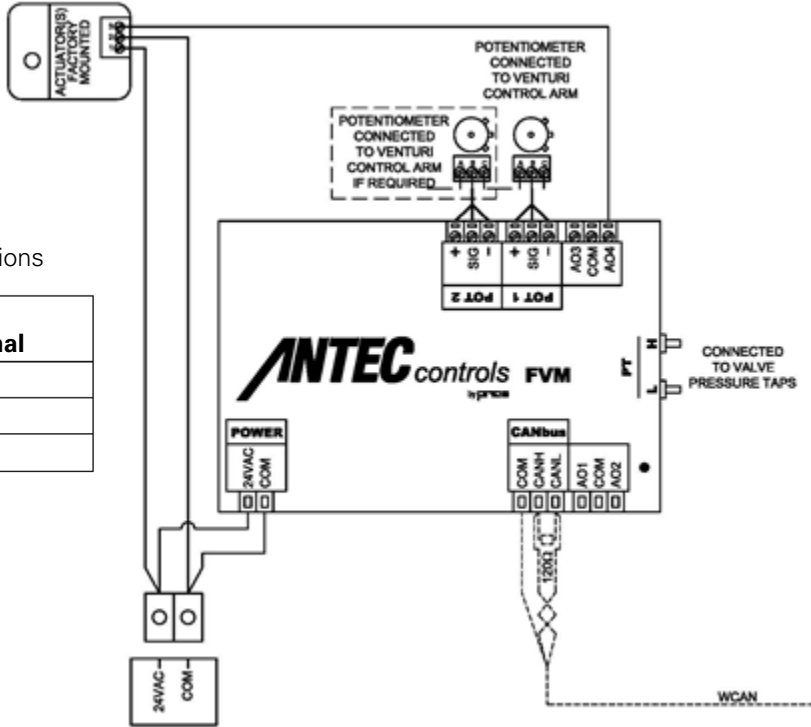

Indicator Color	Description
Solid Green	Device is functioning properly
Blinking Green	Used for ping identification
Solid Magenta	No firmware on device

NOTES:

1. For Typical CAN Wiring Diagrams, see [Controller Area Network \(CAN\)](#) section.
2. All wire connections to the Fume Hood Valve Module (FVM) screw connection terminals must be between 16-26 AWG wire.
3. Current and voltage drop should be taken into consideration when selecting wire gauge.
4. Wiring above may not reflect those required for your project. Refer to your Antec Controls Wiring Diagram Package for typical wiring recommendations.

Fume Hood Valve Module (FVM) - Venturi FX Valve (VFX) and Terminal Unit (TU) Applications

The Fume Hood Valve Module (FVM) works directly with Cava™ to accurately meet the target exhaust airflow and fume hood face velocity. The FVM used in Venturi FX Valve (VFX) and Terminal Unit (TU) applications uses high-accuracy pressure readings to measure the airflow through the valve. The FVM delivers this real-time airflow device information to Cava™ for display and communication over CANbus.

See the FVM product submittal on AntecControls.com for Specifications, Dimensions and Wiring.



Mechanical Installation

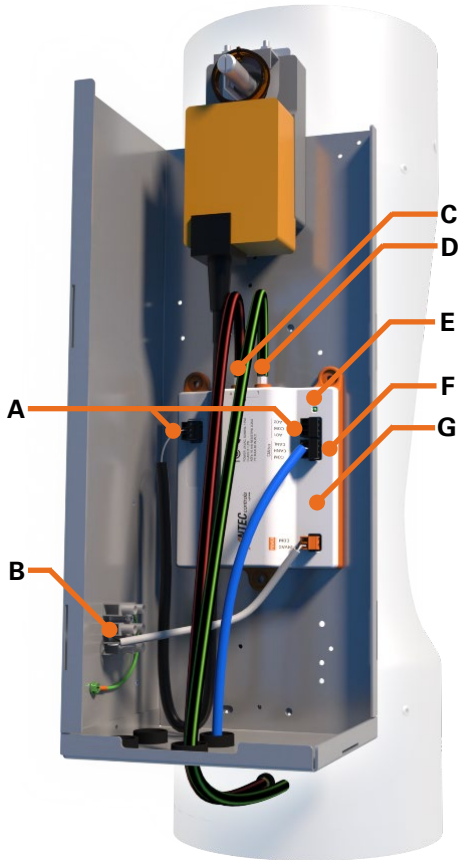

Overview

The FVM is factory calibrated and mounted on the valve with which it was ordered. Only electrical installation is required. Open the controls enclosure on the valve and follow the wiring diagram in the project submittals for electrical installation.

Components

- A** 4 Analog Outputs (0 to 10 VDC, 10 mA Max. Each connected actuator requires 1 output)
- B** Terminal Block to be connected to 24VAC power source (50/60 Hz, 17 VA Max)
- C** High-pressure port
- D** Low-pressure port
- E** Indicator LED
- F** CANbus terminal for connection to CAVA and other CANbus devices
- G** Fume Hood Valve Module (FVM) pre-installed in fume hood valve enclosure

NOTE: The FVM is factory mounted within the enclosure using #8 x 5/16 in. (7.9 mm) screws through three mounting holes.

NOTE: The maximum torque rating for any bushings on the enclosure is 4.43 in.-lbs (0.5 N-m).

Electrical Installation

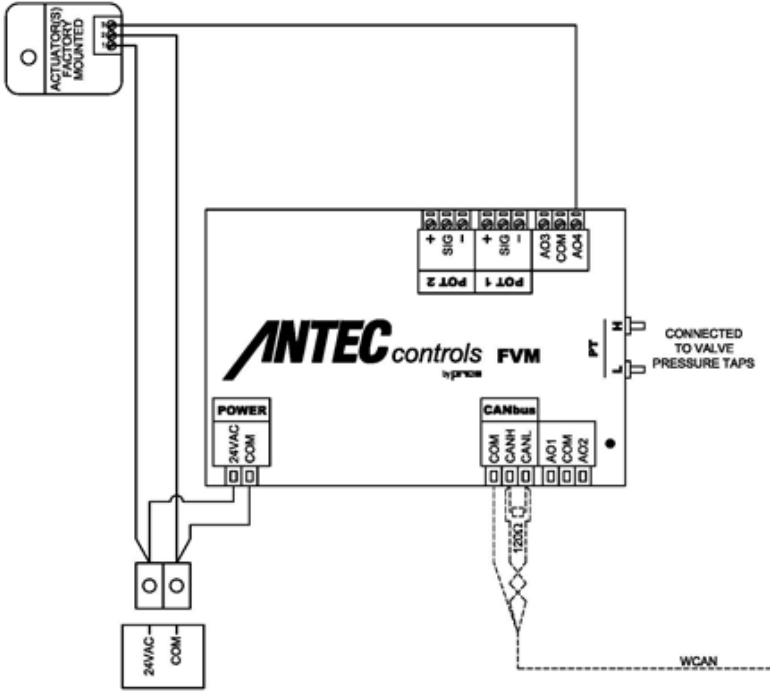

Indicator Color	Description
Solid Green	Device is functioning properly
Blinking Green	Used for ping identification
Solid Magenta	No firmware on device

NOTES:

1. For Typical CAN Wiring Diagrams, see [Controller Area Network \(CAN\)](#) section.
2. All wire connections to the Fume Hood Valve Module (FVM) screw connection terminals must be between 16-26 AWG wire.
3. Current and voltage drop should be taken into consideration when selecting wire gauge.
4. Wiring above may not reflect those required for your project. Refer to your Antec Controls Wiring Diagram Package for typical wiring recommendations.

Sash Position Sensor (SPS)

The Sash Position Sensor (SPS) reports the open area of the fume hood by measuring the vertical height of the sash location. Cava™ uses the SPS measurement to adjust the exhaust airflow based upon the measured sash opening. The SPS contains a long-life potentiometer and is constructed using a stainless-steel cable for stability and a thick plastic cover for protection against airborne chemical agents.



See the SPS product submittal on AntecControls.com for Specifications, Dimensions and Wiring.

NOTE: CAVA can monitor up to three SPS readings. All readings will be summed together to calculate the total open area.

CAUTION

The Sash Position Sensor cable must be mounted as close to parallel as possible with the direction of the sash movement.

Mechanical Installation

The SPS can be mounted in one of four ways. Option A mounts to the counterweight system, Option B mounts directly above the sash outside of the fume hood, Option C also mounts to the counterweight system, and Option D mounts directly in the hood.



Option A

Mount the SPS on the top of the fume hood.

- STEP 1**
Ensure the cable clamp does not pass around a pulley.
- STEP 2**
Run the sensor cable back to the CAVA mounted on the front of the fume hood and connect it to a Universal Input (see [Electrical Installation](#) section).
- STEP 3**
Ensure the sensor cable travels parallel to the counterweight cable.



Option B

Mount the SPS above the sash.

- STEP 1**
Ensure the cable is free from obstruction along the entire length of sash movement.
- STEP 2**
Ensure that the mounting position of the end of the cable will not pass above the SPS even at the maximum sash height.
- STEP 3**
Run the sensor cable back to the CAVA mounted on the front of the fume hood and connect it to a Universal Input (see [Electrical Installation](#) section).

**Option C**

Mount the SPS on the top of the fume hood.

STEP 1

Ensure the cable is free from obstruction along the entire length of sash movement.

STEP 2

The sensor cable may be attached directly to the counterweight. This configuration may be desired when the sash connects to the counterweight with a belt and pulley system.

STEP 3

Run the sensor cable back to the CAVA mounted on the front of the fume hood and connect it to a Universal Input (see [Electrical Installation](#) section).

**Option D**

Mount the SPS on the inside wall of the fume hood. This is the least preferable mounting option, as the sensor is directly in the exhaust air stream.

STEP 1

Ensure that the sensor and cable do not interfere with the mechanical operation of the fume hood sash.

STEP 2

Ensure the sensor is as close to the sash as possible so that the cable is completely parallel to the sash in all positions.

STEP 3

Raise the sash to the fully open position (not just the working height). Screw the metal ring into the sash. Ensure that the sensor is mounted higher than the fully open position of the sash.

STEP 4

Once mounted, raise and lower the sash several times to ensure that the cable is clear of all obstructions and moves freely with the sash.

STEP 5

Run the sensor cable back to the CAVA mounted on the front of the fume hood and connect it to a Universal Input (see [Electrical Installation](#) section).

Sidewall Velocity Sensor (SVS)

The Sidewall Velocity Sensor (SVS) reports face velocity to Cava™ by measuring the differential pressure between the fume hood and the laboratory. Cava™ uses the SVS measurement to adjust the exhaust to meet the target face velocity. The SVS consists of multiple components:

- Sidewall Velocity Sensor (SVS)
- 1 ft x 3.5 in. (304.8 x 88.9 mm) 3M Dual Lock Fastener
- Two brass bulkheads with vent screws
- Two 1.5-foot (457.2 mm) lengths of high-pressure tubing

See the SVS product submittal on [AntecControls.com](https://www.antecontrols.com) for Specifications, Dimensions and Wiring.



Mechanical Installation

The SVS can be mounted in one of three locations. Option A mounts on top of the fume hood, Option B mounts in the side panelling (chase) of the fume hood, and Option C mounts in the front panelling of the fume hood.

Mounting options may be limited by tubing length and vent screw locations. Keep in mind the following considerations when selecting a location.

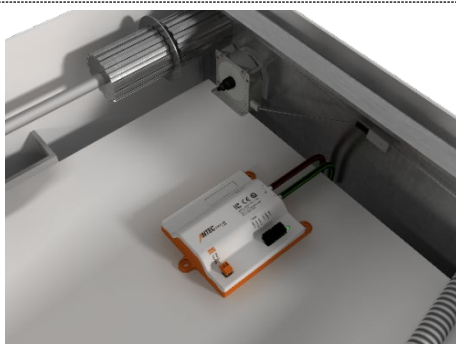

Option A

Mount the SVS on top of the fume hood.

- Tubing runs over the top of the fume hood and down the side panelling (chase) and should not exceed the length of the tubing provided with the SVS.
- Must ensure tubing and wiring do not interfere with the mechanical operation of the fume hood sash.

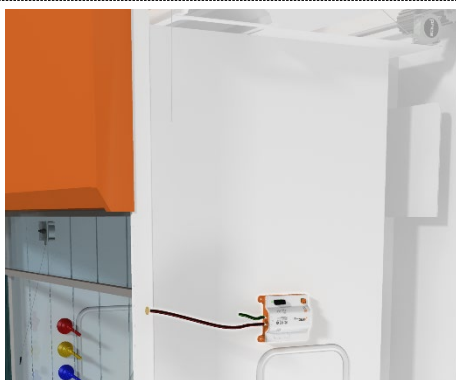

Option B

Mount the SVS in the side panelling (chase) of the fume hood.

- Exterior wall of chase is often removable for maintenance. If sensor is mounted to this wall, it will need to be disconnected for removal.
- Ideal mounting location is on interior wall above the inside wall access panel.



Option C

Mount the SVS in the front panelling of the fume hood.

- Tubing runs from front panelling to side panelling, which may require passthrough holes to be drilled depending on fume hood design.

! CAUTION ▼

Mounting position is critical to ensure the accuracy of the SVS. Ensure that there are no sharp bends or kinks in the tubing during the installation. Improper installation will cause failure of the SVS.

Regardless of where the SVS is mounted, the following steps outline how to install the SVS components.

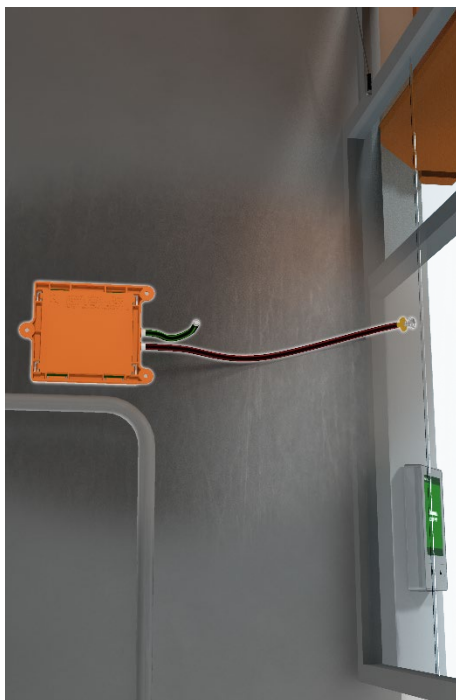

STEP 1

With the sash in the fully open position, drill a 5/16 in. (7.94 mm) hole 5 in. (127 mm) above and 5 in. (127 mm) inward from the base of the sash.

STEP 2

Drill a 5/16 in. (7.94 mm) hole on the front of the fume hood on the same side as the first hole.

STEP 3

Mount the brass bulkheads to the fume hood through the holes.

STEP 4

Select one of the three mounting options on the previous page for the SVS and mount using one of the two methods outlined below:

For 3M Dual Lock Fastener mounting (recommended), clean the mounting surface and the back of the sensor with a cloth or IPA. Wait 5 minutes for IPA to evaporate if used. At room temperature, peel backing from one side of the 3M fastener and apply it to the back of the sensor. Peel backing from opposite side of the 3M fastener and firmly press the SVS and 3M fastener onto the mounting surface for 30 seconds.

For screw mounting, place sensor in desired location and mark the three mounting hole locations on the fume hood. Drill three 1/8 in. (3.2 mm) pilot holes in the appropriate locations on the fume hood. Mount sensor using three #8 x 5/16 in. (7.9 mm) screws.

STEP 5

Use the high-pressure tubing to connect the outer brass bulkhead to the high-pressure port of the sensor. Do the same to connect the inner brass bulkhead to the low-pressure port of the sensor.

Electrical Installation

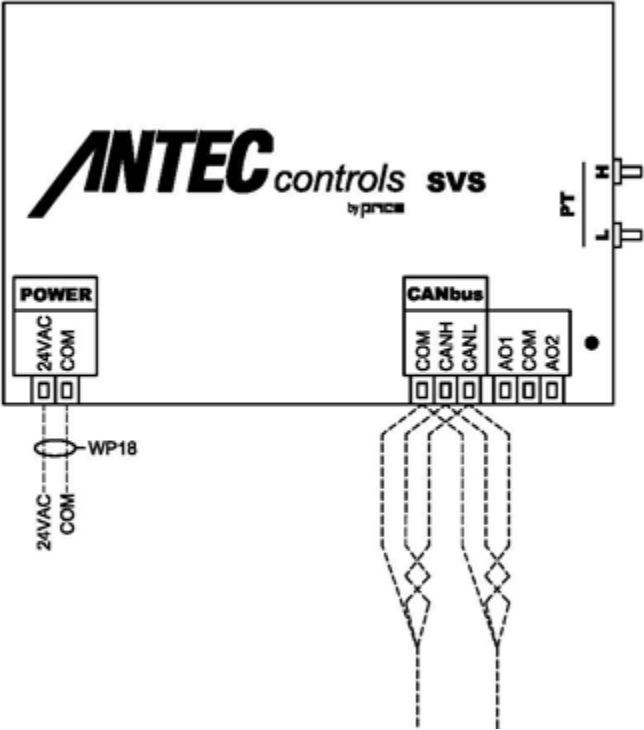

Indicator Color	Description
Solid Green	Device is functioning properly
Blinking Green	Used for ping identification
Solid Magenta	No firmware on device

NOTES:

- 1. For Typical CAN Wiring Diagrams, see [Controller Area Network \(CAN\)](#) section.
- 2. All wire connections to the SVS screw connection terminals must be between 16-26 AWG wire.
- 3. Current and voltage drop should be taken into consideration when selecting wire gauge.
- 4. Wiring above may not reflect those required for your project. Refer to your Antec Controls Wiring Diagram Package for typical wiring recommendations.

Fume Hood Presence Sensor (FPS)

The Fume Hood Presence Sensor (FPS) detects user movement in the vicinity of the fume hood and sends a signal to Cava™. Based on the signal, Cava™ responds by adjusting to a configurable fume hood mode. The FPS boasts a low profile and allows for an adjustable coverage pattern.

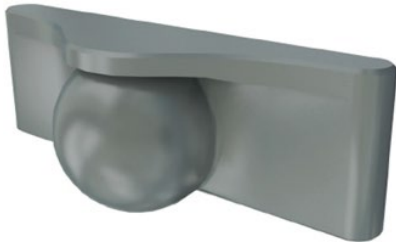

See the FPS product submittal on AntecControls.com for Specifications, Dimensions and Wiring.

Mechanical Installation



STEP 1

Remove the cover of the presence sensor by placing the blade of a small screwdriver in the notch in the right side of the cover and prying upwards as shown. Always remove the cover in this manner.

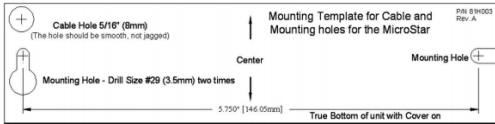

STEP 2

Drill two screw pilot holes and one wire passage according to the provided template in [Appendix A](#).

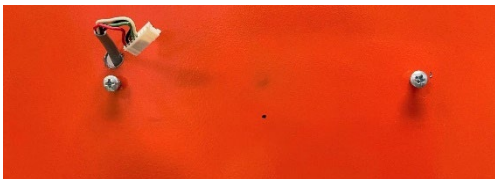

STEP 3

Insert mounting screws partially into holes and route the wire harness through the wire passage hole. Connect the wire harness to power and a Universal Input on the back of CAVA (see [Electrical Installation](#) section).



STEP 4

Route the wire harness through the hole in the presence sensor. Install the presence sensor onto the mounting screws and tighten.



STEP 5

Connect the wiring harness to the presence sensor. Apply power to the unit and wait for the LED to become a solid color. Green indicates no detection and red indicates detection.



STEP 6

Attach the cover by engaging the left side first and then gently snapping the right side of the cover into place.

CAUTION ▼

Shut off power to Cava™ before wiring the sensor. Always ensure wiring is located clear of any moving parts to avoid damage.

INTERFACE

Home Screen

The Cava™ Home Screen will be displayed on the interface once setup has been completed through Antec Toolbox. The Home Screen provides the user with a clear indication of the fume hood status and face velocity reading.

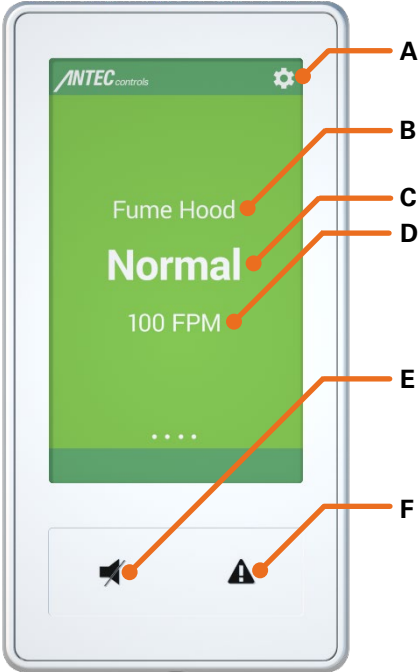

Home Screen Components

Display Component	Description
A Settings Menu	Allows access to settings under password protection. Default password is 1-6-6-4 and can be changed using Antec Toolbox.
B Fume Hood Name	The current name of the fume hood is displayed. This can be changed using Antec Toolbox.
C Fume Hood Status	Indicates the status of the fume hood and any special conditions that may be present.
D Face Velocity	Displays current fume hood face velocity.
E Mute Button	Used to temporarily silence an alarm for a configurable number of minutes (see User Preferences section).
F Emergency Button	Used to quickly enter emergency mode, triggering an alarm. Once triggered, it can be disabled by pressing the Emergency Button for 5 seconds.

Four screens containing additional information regarding the functionality and state of the fume hood can be accessed from the home screen by swiping left. The user can return to the home screen at any time using the home button in the top right corner.



- 1 Displays the control method, fume hood mode, face velocity target and current sash open percentage if a sash position sensor is connected.
- 2 Displays the current face velocity, current valve airflow, current valve pressure (when used with Venturi Valves) and current actuator voltage.
- 3 Displays the sash height of any sash position sensors wired into CAVA.
- 4 Displays information about the Cava™ device and can be accessed through the info button in the bottom right corner.

Configurable Fume Hood Modes

Cava™ comes with four fully configurable fume hood modes. These modes can be configured and updated through Antec Toolbox by using the RIN Ethernet Port on the back of the device.

NOTE: The fume hood modes will be configured during system start-up by your local certified start-up technician. Refer to your start-up technician for changes to your fume hood modes.

Antec Toolbox Fume Hood Mode Options

NOTE: Default Fume Hood Modes = Occupied, Unoccupied, Emergency, Custom

Mode Option	Available Options	Description
Name (Global)	19 Characters	Set the name of the mode that will be displayed on CAVA and reported to BACnet
Control Method	Face Velocity Constant Volume Full Open Full Close	Determines the method with which CAVA will control the fume hood. NOTE: Face Velocity requires a face velocity setpoint, minimum flow, and maximum flow. NOTE: Constant Volume requires a target flow.
Priority (Global)	First Second Third Default	Determines which mode will be entered when multiple modes meet their entry conditions. Default has the lowest priority.
Mode Entry Delay	No Limits	Number of seconds CAVA will wait to enter mode while entry condition is met. NOTE: This is not configurable in the Default priority mode.
Mode Exit Delay	No Limits	Number of seconds CAVA will wait to exit mode while exit condition is met. NOTE: This is not configurable in the Default priority mode.
Color (Global)	Green Red Blue Yellow	Background color on CAVA Home Screen
Trigger Alarm (Global)	On Off	Set whether an alarm will be triggered when the mode is entered.

NOTE: Global mode options are common between each Cava™ in a room to provide consistency between fume hoods.

Alarms



Alarm Notification Screen

If any alarms are triggered, an alarm notification screen will appear and indicate the cause of the alarm. The user can also trigger an emergency purge at any time using the large tactile emergency button.

Silencing the Alarm

When an alarm notification screen appears, the user will have the option to silence the alarm for a configurable amount of time (see [User Preferences](#) section). If the user is wearing gloves, the large tactile mute button can also be used to silence the alarm.

Settings

The settings are accessible through the Home Screen and are password protected (see [Home Screen](#) section).

Settings Menu

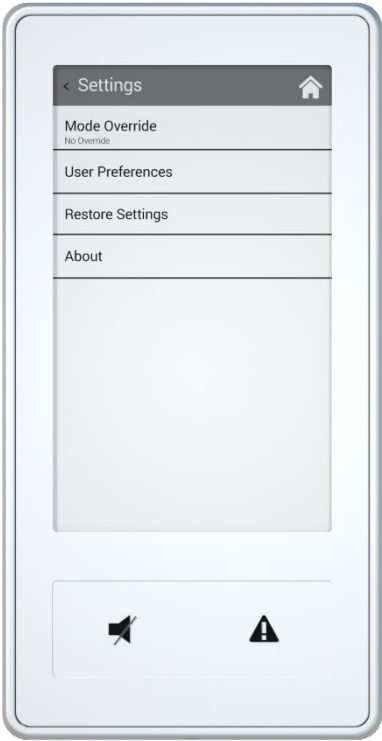

Menu Item	Available Options	Description
Mode Override	No Override [Fume Hood Mode #1] [Fume Hood Mode #2] [Fume Hood Mode #3] [Fume Hood Mode #4]	Used to override current CAVA mode and enter any other mode. All modes are user-configurable from within Antec Toolbox. NOTE: Any overrides done locally through the CAVA touchscreen will take priority over BACnet and Normal Operation.
User Preferences	See below	Allows user to adjust various display and indicator settings.
Restore Settings	OK Cancel	Used to remove all locally changed settings and overrides.
About	None	Displays current details about the CAVA including firmware and part number.

User Preferences

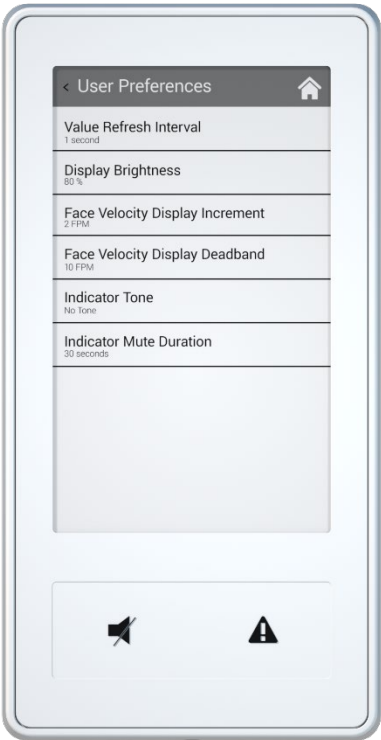

Menu Item	Available Options	Description
Value Refresh Interval	0.5 seconds 1 second (Default) 1.5 seconds 2 seconds	Set the amount of time between the update of the displayed values.
Display Brightness	20% 40% 60% 80% (Default) 100%	Set the display brightness.
Face Velocity Display Increment	1 FPM (0.005 m/s) 2 FPM (0.01 m/s) (Default) 5 FPM (0.025 m/s) 10 FPM (0.05 m/s) 15 FPM (0.076 m/s)	Set the resolution of the face velocity to be displayed.
Face Velocity Display Deadband	1 FPM (0.005 m/s) 2 FPM (0.01 m/s) 5 FPM (0.025 m/s) 10 FPM (0.05 m/s) (Default)	Set the range around the face velocity target within which no updates to the displayed value will occur.
Indicator Tone	Red Alert Wail Steady 2 kHz No Tone (Default)	Set the sound CAVA will emit during an alarm.
Indicator Mute Duration	10 seconds 30 seconds (Default) 1 minute 5 minutes 15 minutes 60 minutes Permanent	Set the amount of time an alarm will be muted for when the Mute button or Silence Alarm button is pressed.

MAINTENANCE

Troubleshooting

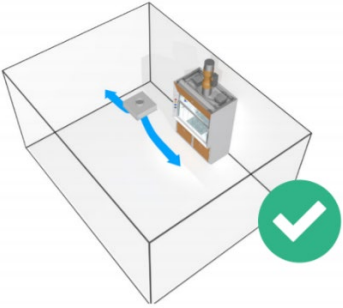
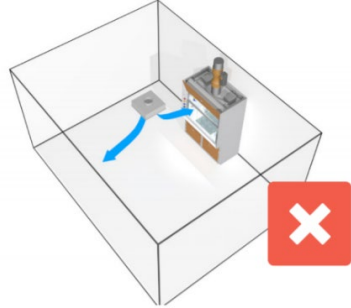
Symptom	Solution
CAVA is non-responsive	<p>Check the power connection to CAVA.</p> <p>Ensure CAVA has 24VAC power with a voltmeter.</p> <p>Cycle power to CAVA.</p>
Binary Output not functioning	<p>Ensure CAVA has 24VAC power.</p> <p>Ensure the Binary Output has been configured to the appropriate usage.</p> <p>CAVA provides a low side binary output. Ensure that the device is connected to a 24VAC supply and that its common is connected to a CAVA binary output.</p>
Sash Height reading does not match the actual sash height	<p>Ensure the SPS is installed according to one of the methods outlined in this manual.</p> <p>If using a cable clamp, ensure it has not slipped.</p> <p>Confirm the sash is not attached to any rotational shafts that might not move linearly with the sash's movement.</p> <p>Check that the cable is free from obstruction.</p> <p>Check that the cable moves smoothly and that there are no breaks in the cable.</p> <p>Recalibrate the SPS.</p>
Sidewall Velocity Sensor (SVS) reading is not stable/accurate	<p>Ensure the SVS is installed according to the method outlined in the Sidewall Velocity Sensor section.</p> <p>Ensure the power and CANbus wiring is fully connected on both ends.</p> <p>Ensure the tubing is fully connected to the SVS.</p> <p>Ensure tubing length is less than 5 feet (1.52 metres).</p> <p>Re-calibrate the sensor.</p> <p>Check diffuser location. If air is flowing across the face of the sash due to diffusers, pedestrians or doors, then you may experience erratic readings.</p> <div style="display: flex; justify-content: space-around; align-items: center;">   </div>
FVM or SVS not recognized by CAVA	<p>Confirm CANbus wiring according to the typical wiring shown in the Fume Hood Accessories section or in the project submittal package.</p> <p>Ensure the end of line device on the CANbus segment is terminated by connecting a 120 ohm resistor between the CANH and CANL network terminals.</p>
Laptop unable to connect to CAVA	<p>Disable any firewalls that may be active.</p>
BACnet is not communicating	<p>Confirm wiring according to the typical wiring shown in this manual or in the project submittal package.</p> <p>Ensure the RJ45 end has been crimped according to T586B.</p> <p>Ensure there are no duplicate MAC addresses on the MS/TP segment.</p> <p>Ensure there are no duplicate Device Instances in the building/facility.</p> <p>Ensure the CAVA's Baud Rate matches the rest of the network.</p> <p>Devices by Others on the BACnet trunk can cause communication issues. If TSI is on the network, make sure their devices are addressed before the Antec Controls devices.</p>

Replacement Parts

Replacement parts are available. Please contact your local Antec Controls Representative.

Technical Support

If technical support is required, please contact us:

By Email: Applications@AntecControls.com

By Phone: 866.884.3524

Hours of Operation: Monday – Friday, 8:00 AM to 4:30 PM CT

NOTE: If you will need support after hours, please contact us 48 hours in advance.

APPENDIX A

Cava™ Jigsaw Cut-Out

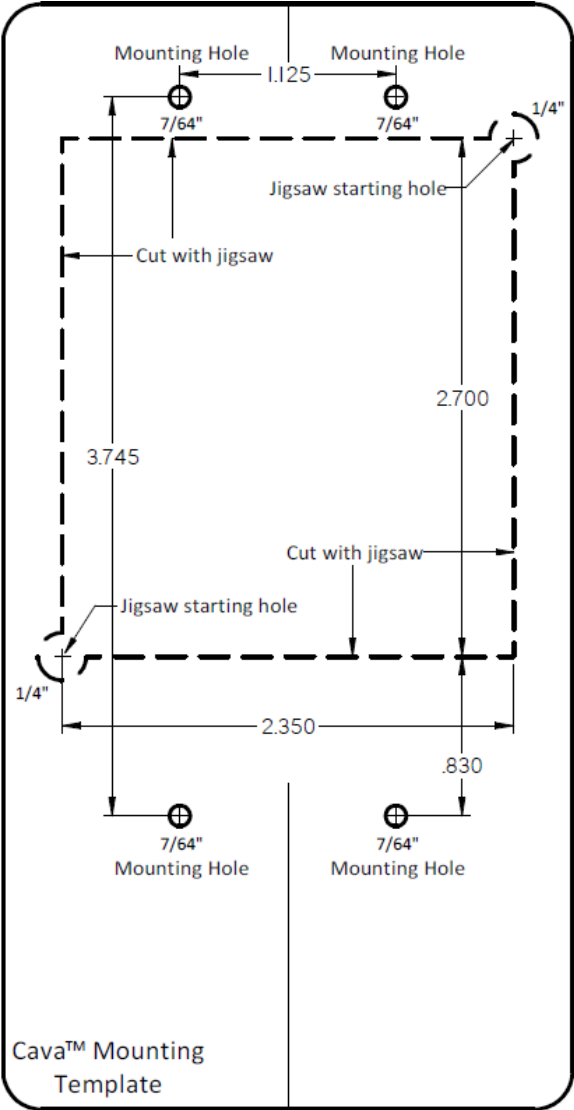

Cava™ Circular Cut-Out

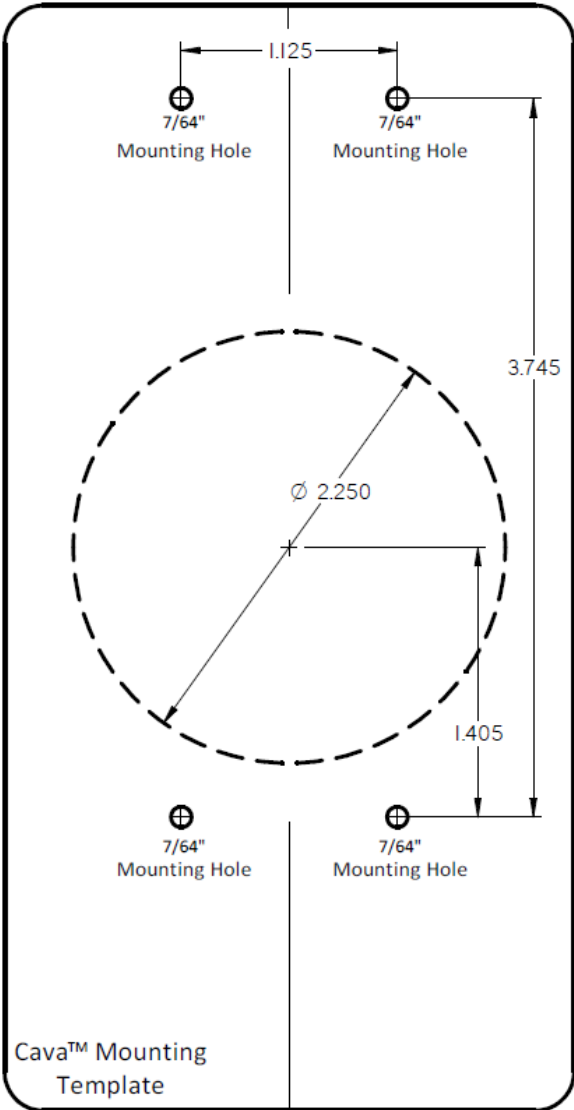

Fume Hood Presence Sensor

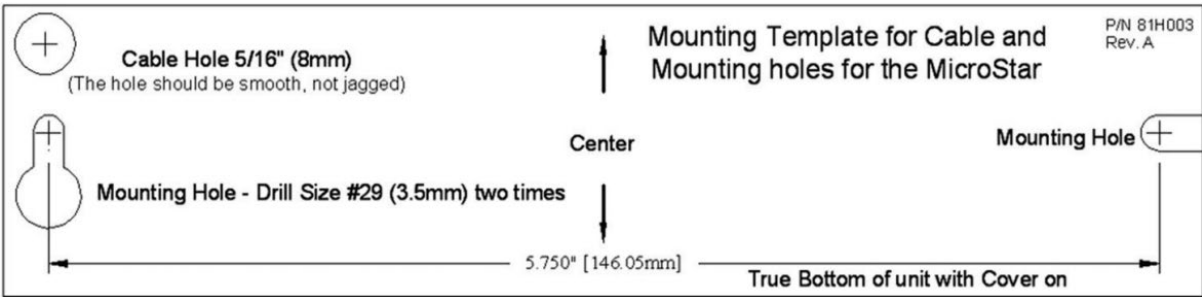



Product Improvement is a continuing endeavour at Antec Controls by Price. Therefore, specifications are subject to change without notice. Consult your Sales Representative for current specifications or more detailed information. Not all products may be available in all geographic areas. All goods described in this document are warranted as described in the Limited Warranty.

The complete product catalog can be viewed online at AntecControls.com
© Antec Controls by Price is a registered trademark of Price Industries Limited.

© 2022. Printed in Canada. v101