

A Factory-Installed Solution

TAMCO Factory-Installed Actuators

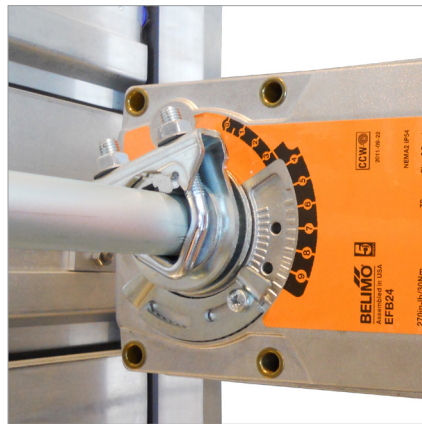

EXPERIENCE TRUE EXCELLENCE IN SERVICE, QUALITY,
AND MAINTENANCE-FREE PERFORMANCE.

ECONOMICAL & EFFICIENT ▼

TAMCO presents a factory-installed actuator solution that results in time and cost savings in the design phase, in shipping, and on the job-site.

PERFORMANCE & ACCURACY ▼

- > TAMCO takes the guesswork out of actuator selection and installation.
- > TAMCO perfectly matches up the actuator model, quantity, and accessories with the torque requirement necessary to operate a specific damper model, size, and configuration.
- > TAMCO factory-installed actuators are optimally positioned to maximize actuator performance and provide a tight seal between damper blades. Every actuator undergoes quality control testing, and is electrically or pneumatically cycled prior to being approved for shipment.
- > Accurate positioning is particularly important for pneumatic actuators, as it ensures that the motor is installed at the precise angle and location required to achieve the proper stroke angle.
- > TAMCO ensures that all the accessories needed for secure fitting and correct operation have been provided.

MODULAR SHIPPING METHOD ▼

- > TAMCO has developed a factory-installed actuator solution that is unique in our industry.
- > TAMCO's system for factory mounting actuators to multiple-section dampers accommodates shipping individual sections, unlike other manufacturers, whose actuator installation methods necessitate cumbersome and expensive shipping of fully-assembled large damper units.
- > TAMCO's modular method reduces transport costs by eliminating the need to make allowances for oversized shipments. TAMCO can ship multiple-section dampers with factory-installed actuators using standard-sized pallets.
- > TAMCO's modular method has the additional advantage of reducing shipping damage, which is an inherent problem when shipping pre-assembled large dampers.

EASE OF INSTALLATION ▼

- > Since dampers arrive on-site with the actuators and accessories preselected and pre-installed, costly job-site installation time and the possibility of installation error are significantly reduced.
- > TAMCO's individually shipped damper sections are much easier to transport, lift, and fit in place than fully assembled dampers that are heavy and unwieldy.
- > This also facilitates installation in areas where space and access may be limited.
- > Installing individual sections helps to ensure that each section, as well as the entire damper assembly are installed square and true.

ELECTRIC ACTUATORS – DIRECT-COUPLED (EXTERNAL) ▾

DIRECT-COUPLED TO
DRIVE ROD

Applies to Flanged to Duct and Extended Rear Flange Install Types only.

(Vertical jackshaft shown.)

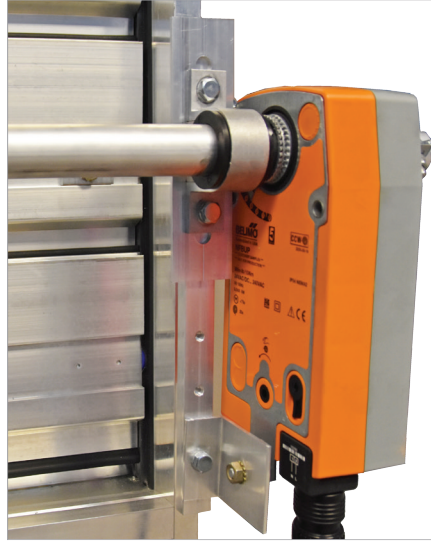
DIRECT-COUPLED TO
JACKSHAFT

Applies to Flanged to Duct* and Extended Rear Flange Install Types only.

* Flanged to Duct damper installation is only possible on one side of the damper (rear) for these actuator mounting types. Attaching duct work to the face side of the damper is impeded by the presence of the horizontal jackshaft, actuator, and/or actuator mounting accessories.

ELECTRIC ACTUATORS – DIRECT-COUPLED (INTERNAL) ▾

DIRECT-COUPLED TO
JACKSHAFT

Applies to In Duct, Flanged to Duct*, and Extended Rear Flange Install Types.

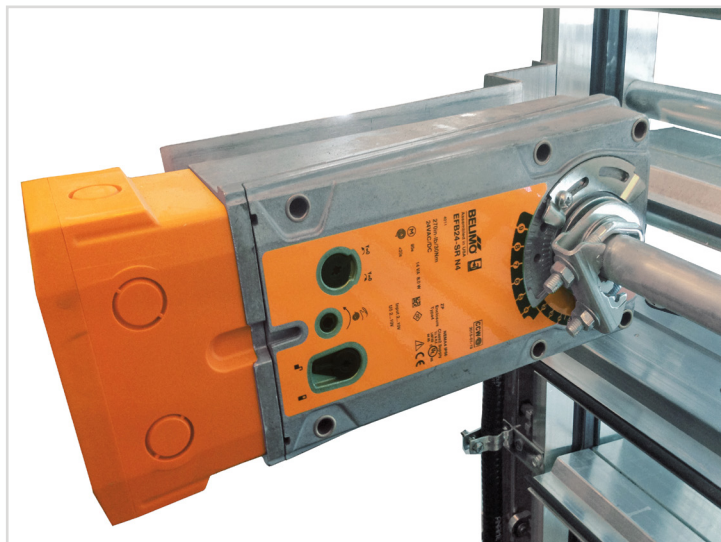
DIRECT-COUPLED TO
JACKSHAFT

Larger actuators, including Belimo EFB models or those with NEMA 4 housings, may be installed at 90° if necessary. Applies to In Duct, Flanged to Duct*, and Extended Rear Flange Install Types.

CONFIGURATIONS FOR DAMPERS WITH FACTORY-INSTALLED ELECTRIC ACTUATORS ▼

The damper configurations depicted herein serve to demonstrate the following for single-section and multiple section dampers:

- › Possible methods of factory-installed electric actuator mounting.
- › How electric actuators may be mounted in conjunction with jumpers, horizontal jackshafts, or vertical jackshafts.
- › How jumper, or vertical or horizontal jackshaft assembly is completed when dampers arrive at the job site.
- › How individual sections with factory-installed electric actuators are assembled when they arrive at the job site.

These examples are intended only to provide general information about how individual sections may be shipped and what may be required to complete damper installation upon delivery.

TAMCO will provide specific details for each damper assembly with factory-installed electric actuators at the time the order is placed, and specific installation instructions will be provided with each shipment. For more information about other damper configurations, contact **TAMCO Customer Service at 1-800-561-3449.**

ELECTRIC - DIRECT-COUPLED TO DRIVE ROD

Each section actuated independently with an externally mounted actuator



- › Shipped as two separate sections, with one factory-installed actuator direct-coupled externally to each section's drive rod.
- › Two sections are to be assembled on job site. *(Refer to TAMCO Aluminum Damper Installation Guidelines.)*

ELECTRIC - DIRECT-COUPLED TO DRIVE HORIZONTAL JACKSHAFT

Both sections actuated from one internal motor location

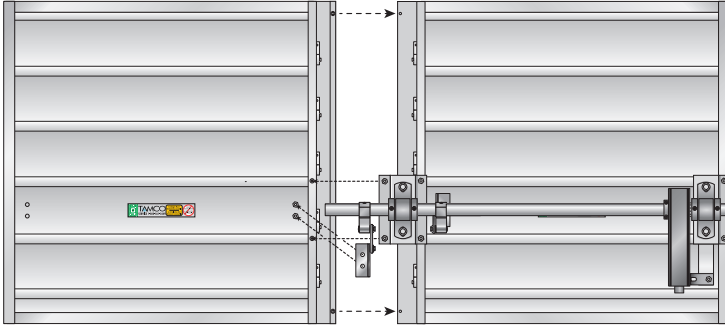

- > Shipped as two separate sections, with one factory-installed actuator direct-coupled internally to the horizontal jackshaft.
- > Horizontal jackshaft is shipped attached to either the left or right section. (*Right-section actuator mounting shown.*) Actuator mounting side must be specified at the time of order.
- > Two sections are to be assembled on job site. (*Refer to TAMCO Aluminum Damper Installation Guidelines.*)
- > Jackshaft bridge bracket and blade clip installation is completed after the two sections have been assembled. (*Refer to TAMCO Horizontal Jackshaft Installation Guidelines.*)

ELECTRIC - DIRECT-COUPLED TO DRIVE HORIZONTAL JACKSHAFT

Both sections actuated from one external motor location

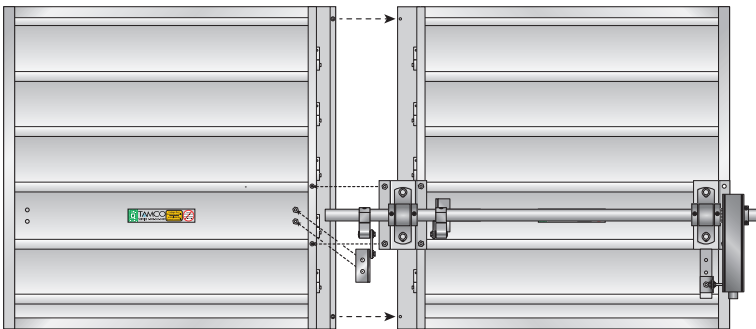

- > Shipped as two separate sections, with one factory-installed actuator direct-coupled externally to the horizontal jackshaft.
- > Horizontal jackshaft is shipped attached to either the left or right section. (*Right-section actuator mounting shown.*) Actuator mounting side must be specified at the time of order.
- > Two sections are to be assembled on job site. (*Refer to TAMCO Aluminum Damper Installation Guidelines.*)
- > Jackshaft bridge bracket and blade clip installation is completed after the two sections have been assembled. (*Refer to TAMCO Horizontal Jackshaft Installation Guidelines.*)

ELECTRIC - DIRECT-COUPLED TO DRIVE ROD

Both sections are connected with a jumper and actuated from one external motor location

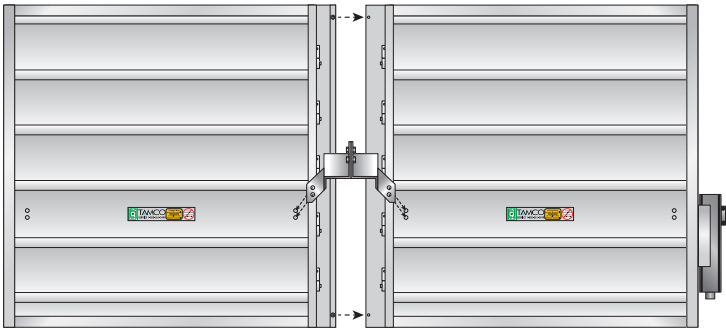

- > Shipped as two separate sections, with one factory-installed actuator direct-coupled externally to either the left or right section. (*Right-section actuator mounting shown.*) Actuator mounting side must be specified at the time of order.
- > Two sections are to be assembled on job site. (*Refer to TAMCO Aluminum Damper Installation Guidelines.*)
- > Jumper is installed after the two sections have been assembled. Jumpers may be used to link two damper sections if the total area connected is less than 30 square feet (2.79 m²). (*Refer to TAMCO Jumper Installation Guidelines.*)

ELECTRIC - DIRECT-COUPLED TO HORIZONTAL JACKSHAFTS

Each section actuated independently with an internally mounted actuator

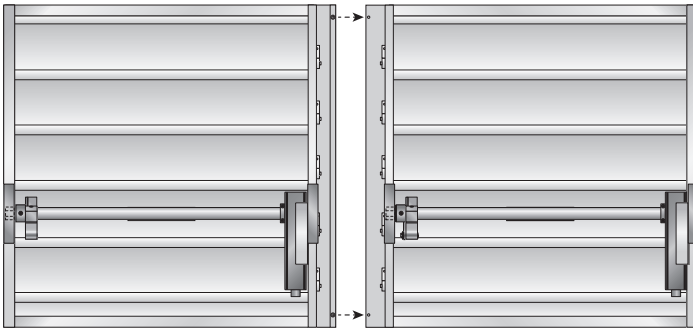

- > Shipped as two separate sections, with one factory-installed actuator direct-coupled internally to each section's horizontal jackshaft. (*Right-hand actuator mounting shown.*) Actuator mounting side must be specified at the time of order.
- > Two sections are to be assembled on job site. (*Refer to TAMCO Aluminum Damper Installation Guidelines.*)

ELECTRIC - DIRECT-COUPLED TO DRIVE ROD

Both sections are connected with a vertical jackshaft and actuated from one external motor location

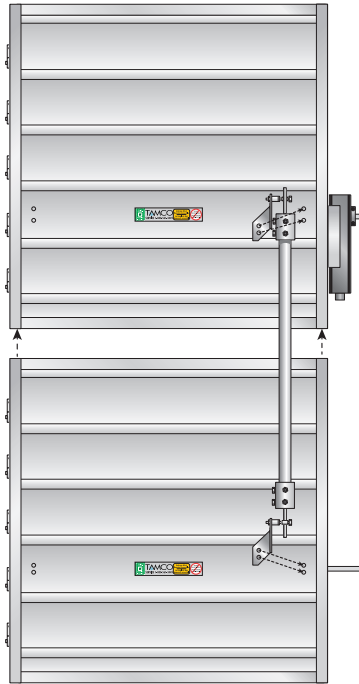

- > Shipped as two separate sections, with one factory-installed actuator direct-coupled externally to the drive rod. (*Right-hand drive shown.*) Drive side must be specified at the time of order.
- > The two vertical sections are to be assembled on job site. (*Refer to TAMCO Aluminum Damper Installation Guidelines.*)
- > The factory-installed actuator may be located on either the top or the bottom section. (*Location on top section shown.*) The section the actuator is to be installed on must be specified at the time of order.
- > Two-section high dampers are shipped with an alignment joiner. (*Not shown in illustration.*)
- > The vertical jackshaft is installed after the two sections have been assembled. (*Refer to TAMCO Vertical Jackshaft Installation Guidelines.*)

ELECTRIC - DIRECT-COUPLED TO HORIZONTAL JACKSHAFTS

Each section actuated independently with an internally mounted actuator

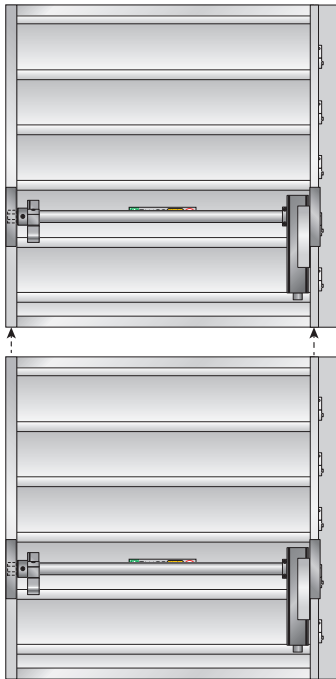

- > Shipped as two separate sections, with one factory-installed actuator direct-coupled internally to each section's horizontal jackshaft. (*Right-hand actuator mounting shown.*) Actuator mounting side must be specified at the time of order.
- > The two vertical sections are to be assembled on job site. (*Refer to TAMCO Aluminum Damper Installation Guidelines.*)
- > Two-section high dampers are shipped with an alignment joiner. (*Not shown in illustration.*)

PNEUMATIC ACTUATORS - REMOTE CONNECTION ▾ to horizontal jackshaft crank arm



FAIL OPEN (INTERNAL)

Will open damper upon loss of air pressure.

Located at the bottom left or right corner of the damper section.

Must be installed in conjunction with a horizontal jackshaft.

Applies to In Duct, Flanged to Duct* and Extended Rear Flange Install Types.



FAIL CLOSE (INTERNAL)

Will close damper upon loss of air pressure.

Located at the top left or right corner of the damper section.

Must be installed in conjunction with a horizontal jackshaft.

Applies to In Duct, Flanged to Duct* and Extended Rear Flange Install Types.

** Flanged to Duct damper installation is only possible on one side of the damper (rear) for these actuator mounting types. Attaching duct work to the face side of the damper is impeded by the presence of the horizontal jackshaft, actuator, and/or actuator mounting accessories.*

NOTE : TAMCO does not factory-install externally mounted pneumatic actuators, as an external surface is required for the installation of the motor mounting plate provided with the actuator. For more information about externally mounted pneumatic actuators, visit the TAMCO website and refer to the Pneumatic Actuator Motor Mounting Accessories page and to the Motor Mounting Methods page.

CONFIGURATIONS FOR DAMPERS WITH FACTORY-INSTALLED PNEUMATIC ACTUATORS ▼

The damper configurations depicted herein serve to demonstrate the following for single-section and multiple section dampers:

- > Possible methods of factory-installed pneumatic actuator mounting.
- > How pneumatic actuators may be mounted in conjunction with jumpers or horizontal jackshafts.
- > How jumper or horizontal jackshaft assembly is completed when dampers arrive at the job site.
- > How individual sections with factory-installed pneumatic actuators are assembled when they arrive at the job site.

These examples are intended only to provide general information about how individual sections may be shipped and what may be required to complete damper installation upon delivery.

TAMCO will provide specific details for each damper assembly with factory-installed pneumatic actuators at the time the order is placed, and specific installation instructions will be provided with each shipment. For more information about other damper configurations, contact **TAMCO Customer Service at 1-800-561-3449**.

PNEUMATIC - REMOTE CONNECTION TO HORIZONTAL JACKSHAFT CRANK ARM

Fail Close - Both sections are actuated from one internal motor location

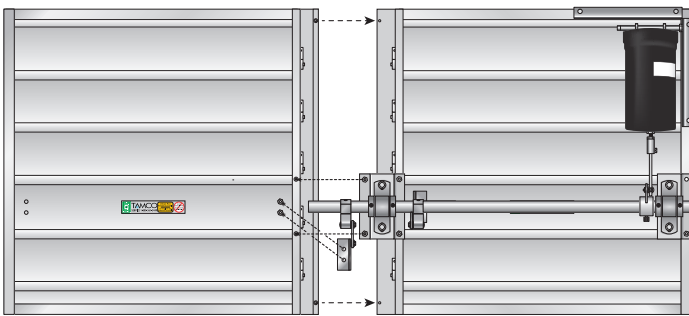

- > Shipped as two separate sections, with one factory-installed actuator mounted internally on a universal motor mounting bracket located at the top of the damper.
- > The actuator is remotely connected to a motor crank arm located on the horizontal jackshaft.
- > Horizontal jackshaft is shipped attached to either the left or right section. *(Right-section actuator mounting shown.)* Actuator mounting side must be specified at the time of order.
- > Two sections are to be assembled on job site. *(Refer to TAMCO Aluminum Damper Installation Guidelines.)*
- > Jackshaft bridge bracket and blade clip installation is completed after the two sections have been assembled. *(Refer to TAMCO Horizontal Jackshaft Installation Guidelines.)*

PNEUMATIC - REMOTE CONNECTION TO HORIZONTAL JACKSHAFT CRANK ARM

Fail Open - Both sections are actuated from one internal motor location

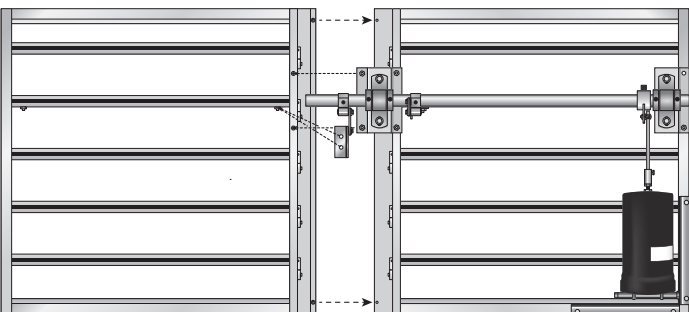

- > Shipped as two separate sections, with one factory-installed actuator mounted internally on a universal motor mounting bracket located at the bottom of the damper.
- > The actuator is remotely connected to a motor crank arm located on the horizontal jackshaft.
- > Horizontal jackshaft is shipped attached to either the left or right section. *(Right-section actuator mounting shown.)* Actuator mounting side must be specified at the time of order.
- > Two sections are to be assembled on job site. *(Refer to TAMCO Aluminum Damper Installation Guidelines.)*
- > Jackshaft bridge bracket and blade clip installation is completed after the two sections have been assembled. *(Refer to TAMCO Horizontal Jackshaft Installation Guidelines.)*

PNEUMATIC - REMOTE CONNECTION TO HORIZONTAL JACKSHAFT CRANK ARM

Fail Close - A single-section damper actuated from one internal motor location

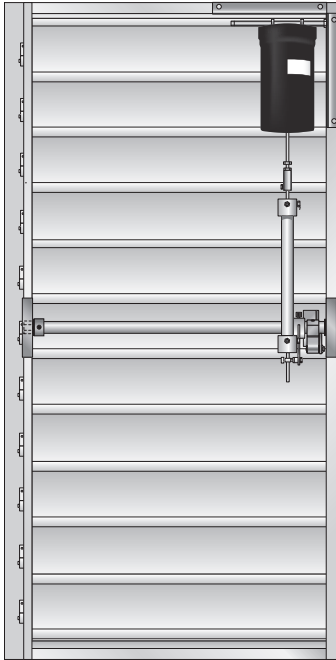

- > Single section shipped with one factory-installed actuator mounted internally on a universal motor mounting bracket located at the top of the damper. *(Right-hand drive shown.)* Drive side must be specified at the time of order.
- > The actuator is remotely connected to a motor crank arm located on the horizontal jackshaft.
- > When damper height reaches or exceeds 26.25 inches (667 mm) OD, a 1 inch (25.4 mm) diameter aluminum rod is used instead of a $\frac{3}{8}$ inch (9.5 mm) diameter push rod. This increases stability and eliminates any bowing or distortion that might occur with a long thin rod.

WHAT INFORMATION WILL TAMCO NEED FROM YOU? ▾

Information required for quotation and order processing

NOTE : The items listed below categorize the information TAMCO will require in order to select and factory-install the actuator that is most appropriate for a specific application or installation. Some, or all of this information may be required to prepare a quote or to process an order. Please contact TAMCO Customer Service to request a quote or to place an order.

FACTORY-INSTALLED ELECTRIC ACTUATORS

▶ Duct velocity or airflow	Expressed as FPM (<i>m/s</i>) or CFM (<i>l/s</i>)
▶ Static Pressure	Expressed as inches w.g. (<i>kPa</i>)
▶ Actuator Type	Spring return, non-spring return, 2 position, modulating, or multi-function
▶ Voltage (VAC/VDC)	24, 120, 230
▶ Run Time	Less than 35 seconds, 35-95 seconds, or more than 95 seconds
▶ Power Fail Action	Fail close or fail open
▶ Options	Nema 4 housing, auxiliary switches, or heaters
▶ Actuator Mount Type	Internal or external
▶ Drive Side	Left- or right-hand drive

FACTORY-INSTALLED PNEUMATIC ACTUATORS

▶ Duct velocity or airflow	Expressed as FPM (<i>m/s</i>) or CFM (<i>l/s</i>)
▶ Static Pressure	Expressed as inches w.g. (<i>kPa</i>)
▶ Spring PSI control*	3-7 psi, 3-13 psi, 5-10 psi, 8-13 psi
▶ Power Fail Action	Fail close or fail open
▶ Options	Pilot positioner, EP switch
▶ Drive Side	Left- or right-hand drive

* Spring PSI control shown above indicates the PSI required to operate the actuator to full stroke while it is not yet connected to the damper. Additional PSI will be required for the actuator to fully open the damper as well.

Distribution network across North America

TAMCO has developed a comprehensive network of representatives, which covers all major urban centers in Canada and the USA.

TAMCO Manufacturing Locations

Ottawa and Smiths Falls,
Ontario, Canada
and Nashville, Tennessee, USA

Visit TAMCO's web site for our newest updates, Video Installation Guidelines, and to find your local TAMCO representative:

www.tamcodampers.com

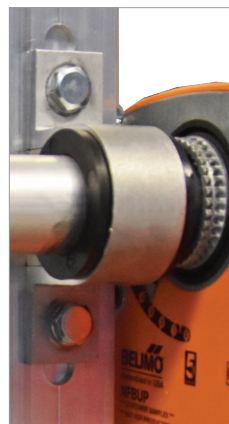
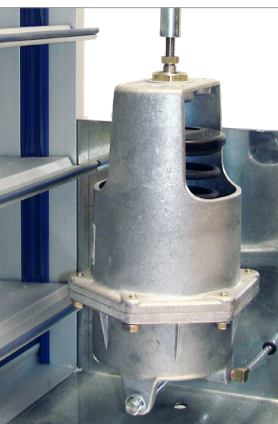

TAMCO

P: 1-800-561-3449
E: sales@tamcodampers.com

27 Iber Road,
Stittsville, Ontario,
Canada, K2S 1E6