



FAN-IQ AIRFLOW MEASUREMENT SOLUTION



FAN-IQ | SMART FAN ARRAY SOLUTION

BENEFITS

- Easy to install backdraft damper with integral airflow measurement device
- Individual fan airflow and temperature measurement (up to 8 fans)
- Single output for total airflow

APPLICATIONS

- Airflow tracking for building pressurization
- Airflow monitoring
- Fan fault detection

GIVE US THIS:

- Fan size
- Number of fans

GET THIS:

- Optimal damper size
- Precise sensor location
- Easy and accurate installation

TWO PREMIER MANUFACTURERS, ONE EXCEPTIONAL PRODUCT



FAN ARRAY PACKAGED SOLUTION | QUALITY, ACCURACY AND LONGEVITY

QUALITY & RELIABILITY

TAMCO® and EBTRON® are known for unsurpassed quality and reliability. This partnership joins the two premier manufacturers and brings together their respective fields of expertise to create a single, premium package that is easy to specify, purchase and install.

TURNKEY SOLUTION

This TAMCO/EBTRON solution combines a premium airflow measuring station with a quality backdraft damper in a laboratory-tested assembly that takes the guesswork out of airflow measurement.

The high quality heavy-duty backdraft design reduces turbulence and pressure losses associated with standard backdraft dampers. The FAN-IQ package is ideal for:

- Fan array airflow and temperature monitoring.
- Fan tracking for building pressurization.
- Individual fan fault detection.

FLEXIBILITY

The TAMCO/EBTRON FAN-IQ package combines EBTRON's Gold Series GTx108e-F/An, high-performance airflow measurement technology with TAMCO Series 7600, 7600 CW, and 7600 CWA Heavy-Duty Backdraft Dampers, providing unprecedented flexibility in airflow measurement at fan inlets. Whether the application is for supply or return fan inlet airflow measurement, the TAMCO®/EBTRON FAN-IQ is the solution.

ACCURACY AND REPEATABILITY

EBTRON's field-proven thermal dispersion technology ensures accurate and repeatable airflow measurement over the entire range of airflow rates and temperatures required by today's high-performance fan array systems. The individual sensor nodes are factory-calibrated at sixteen airflow rates between 0 and 10,000 FPM to NIST traceable standards in EBTRON's state-of-the-art calibration facility.

EBTRON is the only manufacturer that uses highly stable bead-in-glass thermistors at each sensor node. Sensor probes are combined with a high-performance, microprocessor-based transmitter to provide the total airflow rate as well as the individual airflow rates of each fan in the array. This complete system interfaces with your building automation system (BAS) without the need for additional transmitters or transducers. EBTRON airflow sensors do not require periodic calibration or adjustment in most HVAC environments.

MAINTENANCE-FREE PERFORMANCE

TAMCO's aluminum backdraft damper construction provides a prolonged and rust-free operational life. All damper components are designed to provide optimal and completely maintenance-free performance. TAMCO's slip-proof linkage components keep blades aligned as per factory adjustment. The hexagon design feature of the linkage and pivot elements allows for flat-on-flat press fits, eliminating play and wear. TAMCO's Dual Bearing System eliminates action between metal-to-metal and metal-to-plastic riding surfaces. Bearings never require additional lubrication and have a service life of 20 years plus.



A



B



C



D

A TAMCO Heavy-Duty Backdraft Damper Assembly

- A-1 TAMCO's dependable Dual Bearing System
- A-2 TAMCO's slip-proof, maintenance-free linkage system
- A-3 TAMCO's low-leakage blade and frame seals



A-1



A-2

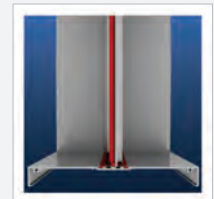

A-3

B TAMCO Sleeve and Flare

- B-1 TAMCO's 1" curved flare



B-1

C EBTRON Airflow Measurement Probes

- C-1 Stable bead-in-glass thermistors
- C-2 FEP plenum-rated cable with gold-plated connector pins



C-1



C-2

D EBTRON Digital Transmitter

- D-1 GTA108e: Two field-selectable (0-5/0-10 VDC or 4-20mA), scalable and isolated analog output signals
- D-2 GTC108e*: One additional field-selectable (BACnet MS/TP or Modbus RTU) and isolated RS-485 network connection.
- D-3 GTM108e*: One additional isolated Ethernet (simultaneously supported BACnet Ethernet or BACnet IP, Modbus TCP and TCP/IP) network connection
- D-4 GTF108e*: One additional isolated Lonworks Free Topology network connection
- D-5 GTU108e*: One additional USB connection for thumb drive data-logging of sensor node airflow rates and temperatures



D-1



D-2



D-3



D-4



D-5

*AO2 can be assigned to temperature, airflow alarm or system status alarm.

*Optional items.

AIRFLOW/TEMPERATURE MEASUREMENT DEVICE FEATURES

- EBTRON's reliable Thermal Dispersion technology is factory-tested and field proven, with hundreds of thousands of devices installed since 1984.
- Precision bead-in-glass thermistors result in long-term stability and drift-free operation.
- Thermistors are potted using a waterproof epoxy and can survive direct exposure to water.
- Sensor probes are provided with durable, FEP-jacketed, plenum-rated cables, which can be exposed to UV and ultra-cold temperatures.
- NIST traceable calibration standards ensure accurate and repeatable measurement.
- Each sensor node (up to 8 per transmitter) is computer-calibrated at 16 airflow rates, to ensure 2% of reading sensor accuracy over the entire operating range.
- Transmitters are available with a wide range of connectivity options, including analog, BACnet, Modbus and Lon.
- Each transmitter is provided with a Bluetooth low-energy interface for Android or iOS devices that allow real-time airflow and temperature monitoring, and near instantaneous airflow and temperature traverses. The transmitters capture, save or e-mail airflow/temperature data, transmitter settings and diagnostics information. The application is free of charge.
- The transmitter can be configured for high/low airflow alarming and includes a unique fan alarm system for individual fan fault detection.
- The airflow measurement device is UL® and FCC Part 15 listed.

HEAVY-DUTY BACKDRAFT DAMPER FEATURES

- The FAN-IQ can be assembled with TAMCO Series 7600, 7600 CW, or 7600 CWA Heavy-Duty Backdraft Dampers.
- The SW – Salt Water Resistance Option is available for Series 7600 and 7600 CW Heavy-Duty Backdraft Dampers, as well as for the FAN-IQ flare.
- The TAMCO Heavy-Duty Backdraft Dampers used for the FAN-IQ Airflow Measurement Station are specially manufactured with a 8.5" (216 mm) wide frame, which acts as an integrated sleeve, accommodating the sensor probe, without obstructing blade operation.
- Aluminum construction contributes to a prolonged and rust-free operational life.
- Aerodynamic, radius entry flare improves accuracy in fan inlet applications.
- TAMCO's engineered backdraft damper, combined with EBTRON's high sensor density probes will not require field-calibration or adjustment when installed in accordance with published guidelines.

Typical heavy-duty backdraft dampers are illustrated below. Complete EBTRON Gold Series GTX108e-F/An Airflow Transmitter options and details are available at www.EBTRON.com.

FAN-IQ TYPICAL HEAVY-DUTY BACKDRAFT DAMPER

FLANGED INSTALL TYPE

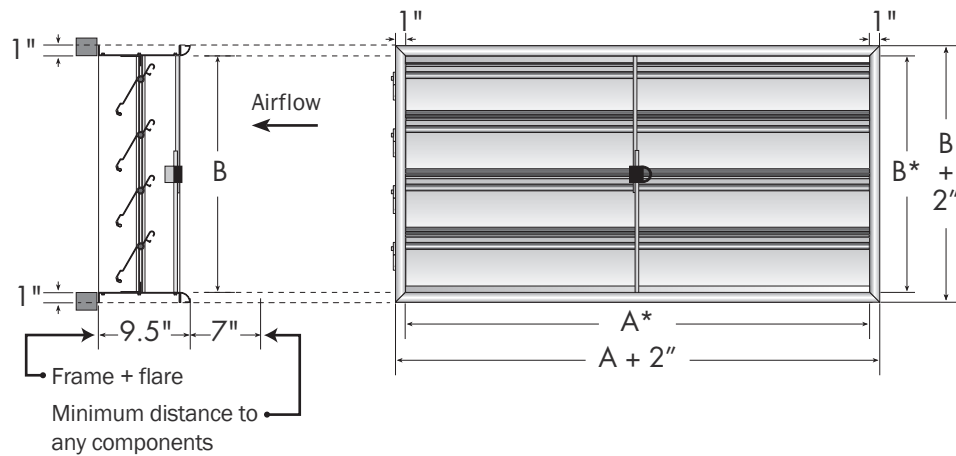

SINGLE-SECTION:

MINIMUM DAMPER SIZE:
12"w x 8"h

MAXIMUM SECTION SIZE:
60"w x 60"h

MAXIMUM SECTION AREA:
25 ft²

*NOTES:

- A x B = Always the opening dimensions
- Width = A: Always the dimension parallel to the blades
- Height = B: Always the dimension perpendicular to the blades

Provide a heavy-duty backdraft damper with an integral airflow/temperature measurement device. Package shall not require any additional duct work or sleeve, when installed in accordance with manufacturer's specified placement guidelines.

Manufacturer and Model:

TAMCO/EBTRON FAN-IQ

Damper and Flare Assembly:

- Provide one or more heavy-duty backdraft damper sections with integral airflow measurement devices for each location indicated on the plans.
- Provide extruded aluminum (6063T5) damper frames, not less than .080" (2.03 mm) thick and 8.5" (216 mm) deep, which act as an integrated sleeve. Frame to be assembled using mounting fasteners. Welded frames shall not be acceptable.
- Provide a 1" (25.4 mm) radius aluminum entry flare, not less than .060" (1.52 mm) thick.
- Provide extruded aluminum (6063T5) backdraft damper blade profiles, not less than 0.09" (2.28 mm) in thickness. Blades shall be designed with a rounded head to reduce pressure loss.
- Blade and frame seals shall be extruded silicone. Seals shall be mechanically fastened to prevent shrinkage and movement over the life of the damper. Adhesive or clip-on type blade seals will not be approved.
- Bearings shall be a dual bearing system composed of a Celcon inner bearing, fixed around a 7/16" (11.1 mm) aluminum hexagon blade pivot pin, rotating within a polycarbonate outer bearing inserted in the frame. Single axle bearing, rotating in an extruded or punched hole shall not be acceptable.
- Hexagonal control shaft shall be 7/16" (11.1 mm). It shall have an adjustable length and shall be an integral part of the blade axle. A field-applied control shaft shall not be acceptable.
- Linkage hardware shall be installed in the frame side and constructed of aluminum and corrosion resistant, zinc-plated steel, complete with cup-point trunnion screws for a slip-proof grip.
- Backdraft dampers shall be custom made to required size, with blade stops not exceeding 1¼" (31.7 mm) in height.
- Backdraft dampers shall be designed for operation in temperatures ranging between -40 °F (-40 °C) and 212 °F (100 °C). *Note that the temperature range for the airflow measuring device differs.*

Integral airflow measuring device:

- Provide one thermal dispersion airflow/temperature measuring device (ATMD) for each fan in the fan array. Differential pressure based devices, including pitot tubes, pitot arrays and piezo rings, are not acceptable.
- Each ATMD shall consist of one to eight sensor probes and a single, remote mounted transmitter.
- Each sensor probe shall consist of one sensor node mounted on a zinc-plated steel probe.

For additional information regarding TAMCO dampers, refer to:

- Series 7600, 7600 CW, 7600 CWA Submittal Documents
- TAMCO Heavy-Duty Backdraft Damper Product Brochure

- Each sensor probe shall consist of one independent sensor node mounted on a zinc-plated steel rod with stainless steel mounting brackets.
- Each sensor node shall consist of two hermetically sealed bead-in-glass thermistors. Chip thermistors of any type or packaging are not acceptable.
- Thermistors shall be potted in an engineering thermoplastic assembly using water-proof, marine epoxy and shall not be damaged by moisture or direct contact with water.
- Each sensing node shall be individually wind tunnel calibrated at 16 points to NIST traceable airflow standards. Provide a copy of the NIST calibration report upon request.
- Signal processing circuitry on or in the sensor probe is not acceptable.
- Each sensor probe shall be provided with a UL listed, FEP jacketed, plenum rated cable(s) between sensor probes and the remote transmitter.
- The ATMD shall be capable of measuring airflow rates over the full range of 0 to 10,000 FPM (50.8 m/s) between -20 °F (-28.9 °C) and 160 °F (71.1 °C).
- Each sensing node shall have a temperature accuracy of +/- 0.15 °F (0.08 °C).
- Each sensing node shall have a calibrated airflow accuracy of +/- 2% of reading.
- The transmitter shall be microprocessor-based and powered by 24 VAC/DC, be over-voltage and over-current protected, and have a watchdog circuit to provide continuous operation after power failures and/or brown-outs.
- All integrated circuits shall be industrial rated.
- All electrical plugs, receptacles and circuit board interconnects shall be gold-plated.
- The power requirement for the ATMD shall not exceed 16 V-A.
- The transmitter shall determine the average airflow rate and temperature of each fan in the array.
- Provide a transmitter with two field-selectable (0-5/0-10 VDC or 4-20mA), scalable, and isolated signals. Available optional outputs are:
 - > One additional field-selectable (BACnetMS/TP or Modbus RTU and isolated RS-485) network connection, or
 - > One additional isolated Ethernet (simultaneously supported BACnet Ethernet or BACnet IP, ModbusTCP and TCP/IP) network connection, or
 - > One additional isolated Lonworks Free Topology network connection, or
 - > One additional USB connection for thumb drive data logging of sensor node airflow rates and temperatures.
- All analog output signals and network connections shall be isolated.
- Provide a Bluetooth, low-energy interface card, to interface with Android or iOS devices.
- Provide free Android or iOS software that allows real-time airflow and temperature monitoring and airflow and temperature traverses. Software shall capture, save or e-mail airflow/temperature data, transmitter settings and diagnostics information.
- BACnet shall be BTL listed.
- The ATMD shall be UL/cUL873 listed
- The ATMD shall be CE marked for European shipments
- The ATMD shall be FCC Part 15 listed
- Each ATMD shall be powered by 24VAC @ 20V-A

For additional information regarding EBTRON airflow measuring devices, refer to EBTRON.com