

**F-4600 INLINE ULTRASONIC FLOW METER**  
**With Optional LCD Display**  
**Installation and Operation Guide**



# SAFETY INFORMATION

This meter was calibrated at the factory before shipment. To ensure correct use of the meter, please read this manual thoroughly.

Regarding this Manual:

- This manual should be passed on to the end user.
- Before use, read this manual thoroughly to comprehend its contents.
- The contents of this manual may be changed without prior notice.
- All rights reserved. No part of this manual may be reproduced in any form without ONICON's written permission.
- ONICON makes no warranty of any kind with regard to this material, including, but not limited to, implied warranties of merchantability and suitability for a particular purpose.
- All reasonable effort has been made to ensure the accuracy of the contents of this manual. However, if any errors are found, please inform ONICON.
- ONICON assumes no responsibilities for this product except as stated in the warranty.
- If the customer or any third party is harmed by the use of this product, ONICON assumes no responsibility for any such harm owing to any defects in the product which were not predictable, or for any indirect damages.

Safety Precautions:

The following general safety precautions must be observed during all phases of installation, operation, service, and repair of this product. Failure to comply with these precautions or with specific WARNINGS given elsewhere in this manual violates safety standards of design, manufacture, and intended use of the product. ONICON Incorporated assumes no liability for the customer's failure to comply with these requirements. If this product is used in a manner not specified in this manual, the protection provided by this product may be impaired.

The following symbols are used in this manual:



## WARNING

Messages identified as "Warning" contain information regarding the personal safety of individuals involved in the installation, operation or service of this product.



## CAUTION

Messages identified as "Caution" contain information regarding potential damage to the product or other ancillary products.



## IMPORTANT NOTE

Messages identified as "Important Note" contain information critical to the proper operation of the product.

# TABLE OF CONTENTS

<b>SECTION 1.0: INTRODUCTION</b> .....	<b>4</b>
1.1 PURPOSE OF THIS GUIDE .....	4
1.2 TYPICAL F-4600 FLOW METER .....	4
1.3 STANDARD FEATURES AND SPECIFICATIONS.....	4
1.4 WORKING ENVIRONMENT .....	6
1.5 SERIAL NUMBER.....	6
<b>SECTION 2.0: UNPACKING</b> .....	<b>6</b>
2.1 CHECKING THAT YOU HAVE RECEIVED EVERYTHING .....	6
<b>SECTION 3.0: INSTALLATION</b> .....	<b>7</b>
3.1 SITE SELECTION .....	7
3.2 INSTALLING THE FLOW SENSOR.....	7
3.3 REMOTE MOUNTING THE ENCLOSURE .....	12
3.4 POWER AND SIGNAL WIRING CONNECTIONS .....	13
<b>SECTION 4.0: F-4600 START-UP AND COMMISSIONING</b> .....	<b>15</b>
4.1 START-UP .....	15
4.1.1 Operating Mode Display Pages.....	16
4.1.2 Additional Display Pages.....	17
4.2 COMMISSIONING.....	18
4.2.1 Commissioning Following Initial Power-up.....	18
<b>SECTION 5.0: DIAGNOSTIC FUNCTIONS</b> .....	<b>22</b>
<b>SECTION 6.0: BACNET MS/TP</b> .....	<b>23</b>
6.1 BACNET® OBJECT TYPES .....	23
6.2 PROTOCOL IMPLEMENTATION STATEMENT .....	23
6.3 DEVICE OBJECT .....	24
6.4 ANALOG INPUT(S).....	25
6.5 ANALOG VALUE(S).....	26
6.6 BINARY VALUE(S).....	27
6.7 MULTI STATE VALUE .....	28
6.8 TREND LOG MULTIPLE .....	29
<b>SECTION 7.0: MODBUS</b> .....	<b>30</b>
7.1 MODBUS MEMORY MAP.....	31
7.2 DIAGNOSTIC FUNCTION CODE .....	34
7.3 REPORT SLAVE ID FUNCTION CODE.....	35
<b>SECTION 8.0: AUXILIARY INPUTS AND OUTPUTS</b> .....	<b>36</b>
8.1 DETERMINING AUXILIARY INPUT AND OUTPUT CONFIGURATION.....	36
8.2 AUXILIARY INPUTS.....	36
8.3 AUXILIARY OUTPUTS.....	37
8.3.1 Pulse Outputs.....	37
8.4 ANALOG OUTPUT .....	38
<b>APPENDIX A</b>	
A-1 F-4600 FLOW WIRING DIAGRAM .....	39
A-2 CHANGING BACNET SETTINGS OR METER PROGRAMMING AFTER COMMISSIONING.....	39
A-3 SELECTING THE RIGHT METER & CALCULATING PRESSURE LOSS.....	39

## SECTION 1.0: INTRODUCTION

### 1.1 PURPOSE OF THIS GUIDE

The purpose of this guide is to provide installation and commissioning procedures, and basic operating and servicing instructions for the ONICON F-4600 flow meter with optional LCD display.



#### WARNING

Only qualified service personnel should attempt to install or service this product. Serious injury may result from the improper installation or use of this product.

### 1.2 TYPICAL F-4600 FLOW METER

The F-4600 inline flow meter utilizes direct path wetted ultrasonic transducers for measuring the volumetric flow and temperature of liquids in a wide variety of applications. The meter is provided with a detachable enclosure with a built-in user interface/display.

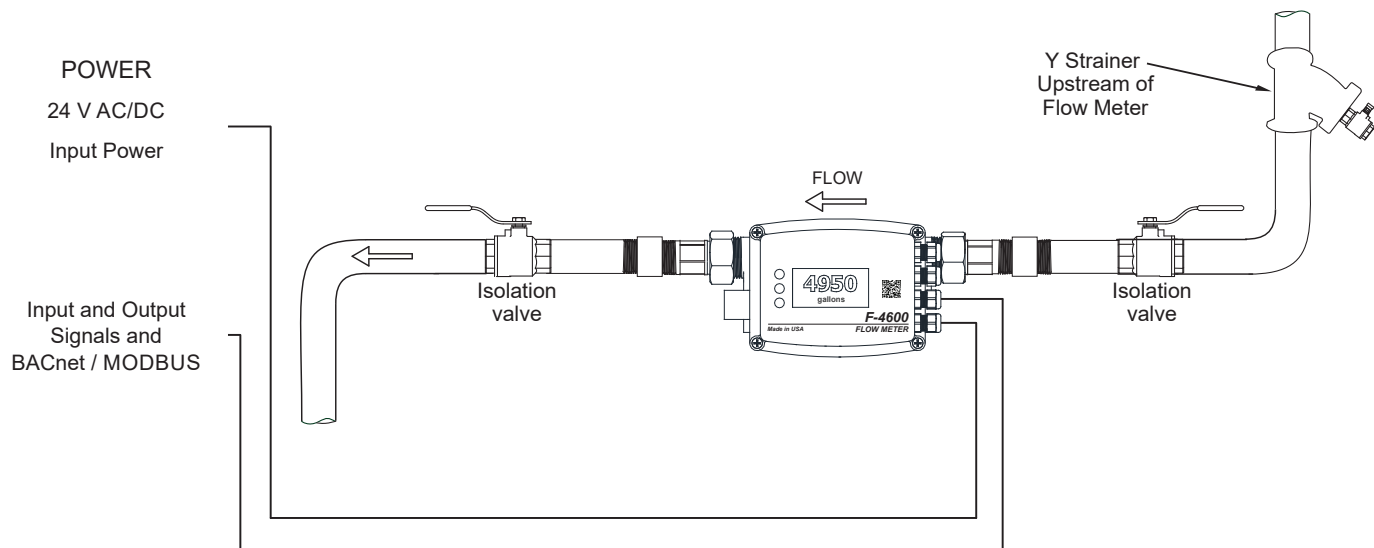

### 1.3 STANDARD FEATURES AND SPECIFICATIONS

- Detachable enclosure with alphanumeric display and user interface
- Three 2-wire signal ports can be configured as pulse input or outputs. One of the ports can be configured as an analog output.

## 1.3 STANDARD FEATURES AND SPECIFICATIONS (CONTINUED)

### ACCURACY

#### FLOW

- ± 1% of reading over 25:1 turndown
- ± 2% of reading over 100:1 turndown
- Repeatability:  $\leq \pm 0.2\%$

### OVERALL FLOW RANGE

500:1 turndown

### SENSING METHOD

Direct beam path wetted ultrasonic sensors utilizing differential transit time velocity measurement

### METER SIZES (Nominal diameter in inches)

½, ¾, 1, 1¼, 1½, 2 and 2½

### PIPING SYSTEM CONNECTIONS

- Male NPT threads
- 2½" meter provided with ANSI Class 150 raised face flanges
- Optional PN16 or ANSI Class 300 raised face flanges

### FLUID TEMPERATURE RANGE

32° F to 250° F

### AMBIENT TEMPERATURE RANGE

-13° F to 131° F

### MAXIMUM OPERATING PRESSURE

400 PSI

### PRESSURE DROP

Less than 1 PSI at 4 ft/sec, decreasing at lower velocities

### POWER SUPPLY REQUIREMENTS

- 12-36 VAC, 50/60 Hz, 5 VA maximum
- 12-42 VDC, 5 W maximum

### PULSE INPUTS, OUTPUTS, and ANALOG OUTPUT

The three 2-wire signal ports can be configured as pulse inputs or outputs. One of the ports can be configured as an analog output.

**Isolated totalizing pulse inputs** for use with sinking open collector or dry contact outputs

Input rating: 30 VDC, 10 mA maximum

Pulse duration: 50 ms minimum

**Isolated totalizing solid state contact closure pulse outputs** may be programmed for energy, volume, alarm indication or coil indication (MODBUS RTU only)

Contact ratings: 50 mA, 30 V

Contact pulse duration: 50, 100, 500 or 1000 ms (500ms default)

**Analog 4-20 mA, 0-5 V or 0-10 V output** for flow rate or temperature

### NETWORK CONNECTION

Isolated RS485 serial interface

### COMMUNICATION PROTOCOLS

BACnet MS/TP per ASHRAE Standard 135.1: 2009  
MODBUS RTU

### NETWORK CONFIGURATION & ADDRESSING

Baud Rates: 4800, 9600, 19200, 38400, 76800, or 115200

Device Address Range: 1 – 255 (1 - 247 MODBUS)

Device Instance Range: 1 – 4,194,303 (BACnet only)

Parity: None, Even, Odd (MODBUS RTU only)

### APPROVALS

FCC: Part 15, Subpart B

CE

Conforms to ANSI/NSF 61 & 372

BTL Certified to ASHRAE 135:2009

NOTE: Specifications subject to change without notice

## 1.4 WORKING ENVIRONMENT

The F-4600 with optional LCD display was designed for installation and use indoors or outdoors in protected spaces, or in residential, commercial and light industrial environments that are free of corrosive liquids and fumes, temperature extremes and excess vibration.

The operating ambient air temperature range is -13° F to 131° F. The electrical power should be relatively clean, free of excess high frequency noise and large voltage transients.

## 1.5 SERIAL NUMBER

### Serial Number

The serial number of your F-4600 is located on the side of the enclosure. The serial number is a unique identifier for the product. Please have this number available when contacting ONICON for assistance.

## SECTION 2.0: UNPACKING

The F-4600 is generally shipped in one package unless optional hardware or equipment is ordered. Notify the freight carrier and ONICON if any items are damaged in transit.

## 2.1 CHECKING THAT YOU HAVE RECEIVED EVERYTHING

The following items have been provided with your F-4600 Flow Meter:

- Two line size process connection meter couplings\* with male NPT threads and sealing gaskets (shipped attached to meter)
- One F-4600 Meter Installation and Operation Guide
- One F-4600 Meter Certificate of Calibration
- One Remote Mount Bracket

Please notify ONICON if any of these items are missing.

\*NOTE: The 2½” version of the meter is provided with flanges.

## SECTION 3.0: INSTALLATION

The F-4600 Flow Meter should be installed by experienced plumbers, electricians, and others with related knowledge and experience in the heating, cooling, and fluid metering fields. ONICON technical support personnel are available via telephone or e-mail to provide technical assistance before, during and after installation. On-site field engineering, installation, and service are also available at an additional cost. The installer should use good trade practices and must adhere to all state and local building, or other, applicable codes.

Before you begin, clean the external surfaces of all pipes at the installation site so that it is free of debris, foreign matter, solids, leak inhibitors, and chemically aggressive substances. Flush the entire system so that it is free of flux, solder, pipe and tube cuttings and any other free moving debris.

### 3.1 SITE SELECTION

Careful attention to the site selection for the meter will help the installers with the initial installation, reduce start-up problems, and make future maintenance easier. For example, do not install the meter where it will be difficult for personnel to perform periodic maintenance. When selecting a site, consider the criteria under Section 1.4: WORKING ENVIRONMENT, as well as the information below.

The following limitations apply to the installation of the meter:

- The flow meter must be correctly oriented with respect to the direction of flow in the pipe. Meters installed with reversed flow will not function.
- The F-4600 is provided with a 4.9 ft (1.5 m) cable for the detachable enclosure. Do not alter this cable length. Doing so will void the calibration and may invalidate the warranty.
- The maximum operating pressure for the flow meter is 400 psi.
- At fluid temperatures above 212° F, the enclosure should be remote mounted.
- Do not install the meter in close proximity to strong sources of electromagnetic interference (e.g. electric motors, VFD's, fluorescent light fixtures, etc.)

### 3.2 INSTALLING THE FLOW SENSOR

Before you install the meter, the entire piping system should be flushed and free of debris. Please refer to the diagrams on the following page when selecting the installation location. Upstream straight unobstructed pipe requirements vary considerably based on nature of the upstream obstructions. As a general rule, ONICON recommends a minimum of 10 diameters of straight unobstructed pipe whenever possible; keeping in mind that it is always recommended that the meter be located with as much straight pipe upstream as possible. Recommended minimum

## STRAIGHT RUN REQUIREMENTS

Upstream Obstruction	Minimum Upstream Straight Run Required (Pipe Diameters)	
	Meter Size	
	0.5 - 1.0"	1.25 - 2.5"
Single Elbow	0	0
Expander / Reducer	0	0
Coil, Upstream	3	3
Isolation Valve, 2 Position	3	5
Control Valve	10	15
<b>Notes:</b>		
1	Straight run is based on use of manufacturer provided couplings	
2	Avoid the following obstructions where possible: Modulating valves, pump discharge, multiple elbows out of plane.	

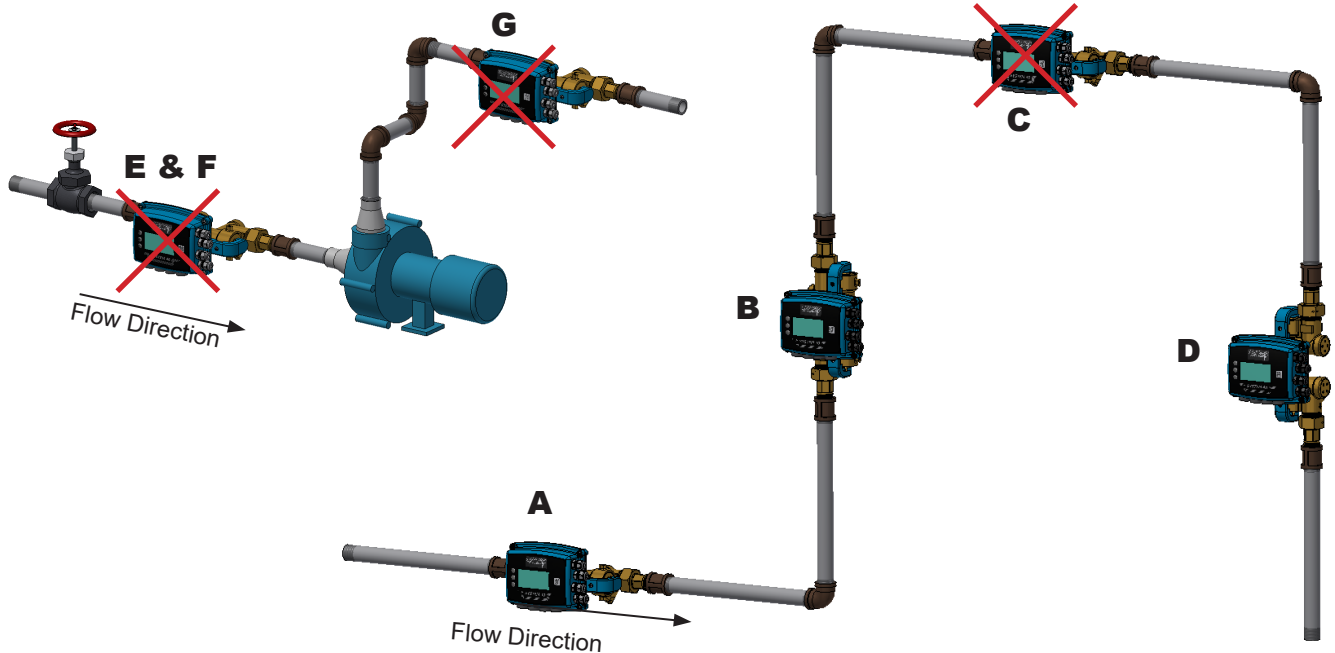

straight run requirements are provided on the following page.

- A. This is a recommended position for the flow sensor.
- B. This is a recommended position for the flow sensor.
- C. Avoid installation locations where air can become trapped in the piping system.
- D. This is an acceptable installation location for closed loop pressurized systems.
- E. Do not install the sensor downstream of modulating valves or partially open valves. Fully open isolation valves (e.g. ball valves) are OK.
- F. Do not install the flow sensor at the inlet of a pump. To prevent cavitation, the minimum operating pressure at the inlet of the meter must always exceed the pressure drop across the meter. Refer to Appendix A-3 for calculating pressure the drop at different flow rates.
- G. Avoid installing the meter downstream of multiple bends out of plane with each other where there are less than 10 diameters of straight unobstructed pipe between bends.



The flow sensor is installed with threaded meter couplings and flat sealing gaskets as shown below. Orient the sensor body by aligning the flow direction arrow with the direction of flow in the pipe.

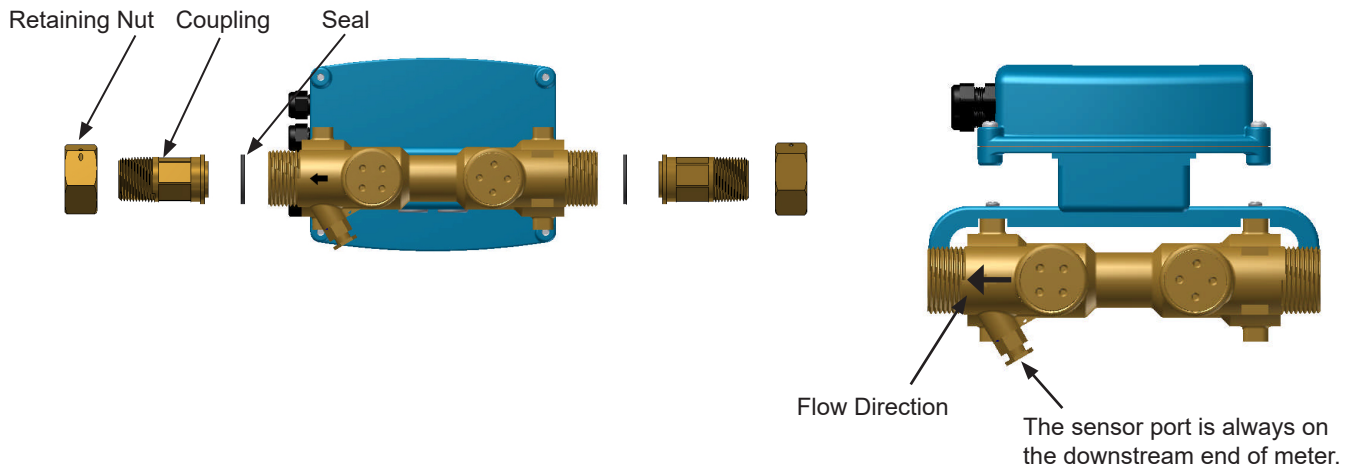

**IMPORTANT NOTE**

The flow sensor body must be correctly oriented with respect to the direction of flow in the pipe. Meters installed with flow in the reverse direction will not function.

For 1/2 - 1" meter sizes the calculator enclosure may be rotated around the axis of the flow sensor into three different positions. To rotate, temporarily slide the enclosure off the flow sensor mounting brackets. Remove the two retaining screws and reposition the mounting brackets as required. Reinstall the enclosure with the display properly oriented for viewing. Mounting tracks on the back of the enclosure allow for mounting in any orientation.

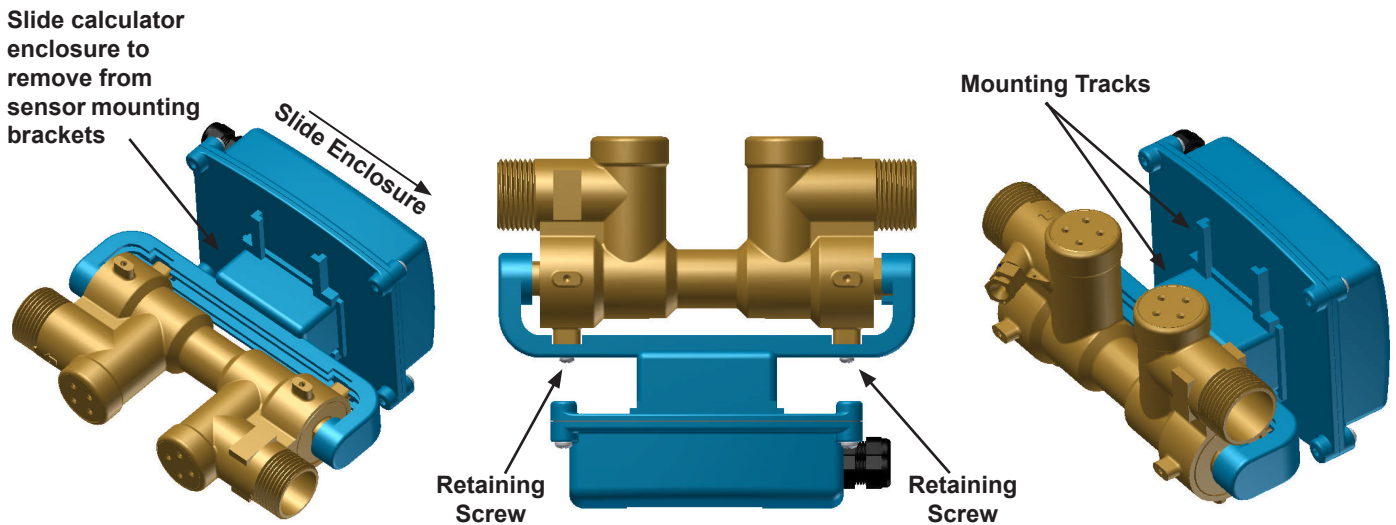

**IMPORTANT NOTE**

When installing the meter in a vertical pipe with upward flow, you must rotate the enclosure back plate 180° when rotating the display 90°. To accomplish this, temporarily remove the 4 cover screws and rotate the backing plate.

Orient the ½ - 1” meters as shown below. The meter may be installed with upward or downward flow in vertical pipes in closed loop pressurized systems. Avoid any installation locations where the pipe may not be completely full.

### Preferred Orientation for Horizontal Housing

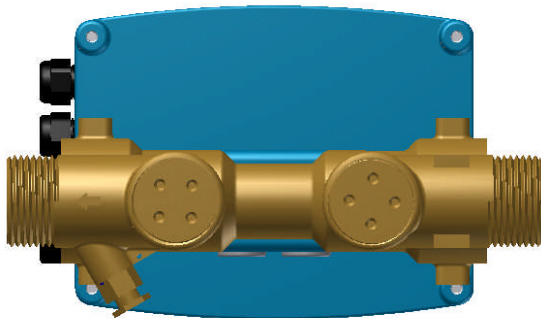

Back View

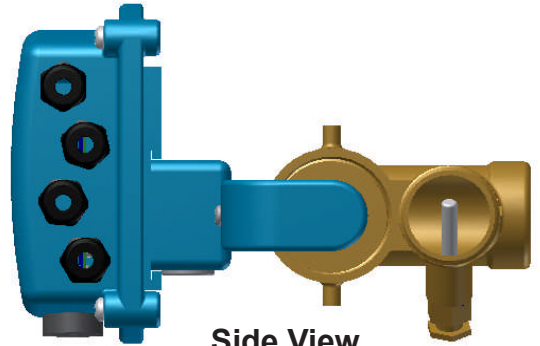

Side View

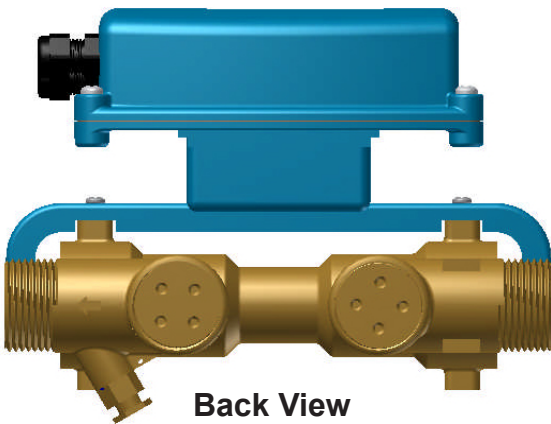

Back View

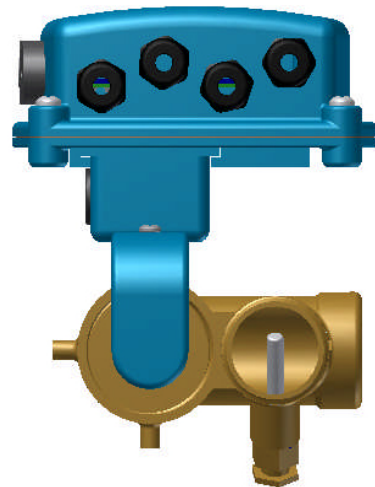

Side View

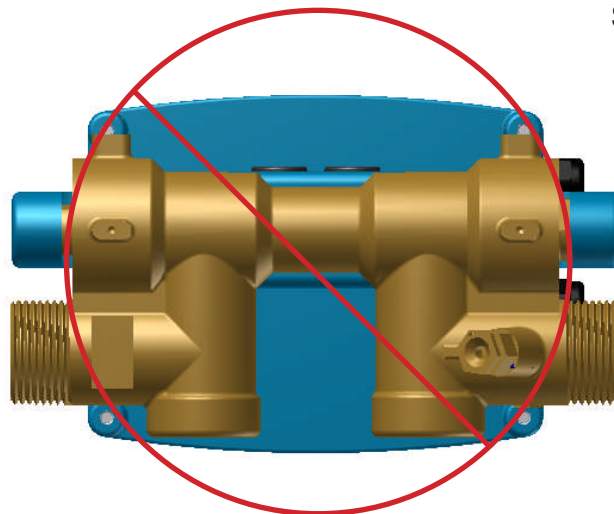

Do not orient meter as shown above

Orient the 1¼ - 2½" meters as shown below. The meter may be installed with upward or downward flow in vertical pipes in closed loop pressurized systems. Avoid any installation locations where the pipe may not be completely full.

### Preferred Orientation for Horizontal Housing

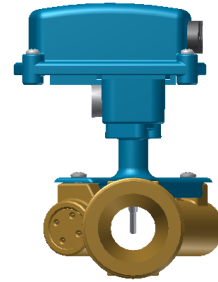
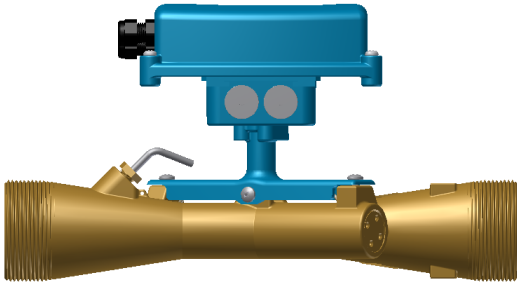

Side View

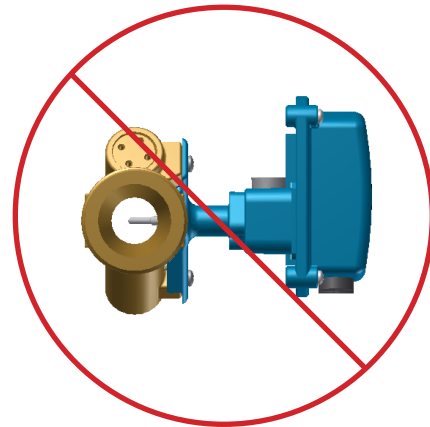

Do not orient meter as shown above

### 3.3 REMOTE MOUNTING THE ENCLOSURE

The F-4600 with display is provided with a mounting bracket and the cables required for remote mounting the enclosure. The cable is 4.9 ft (1.5 m) in length. This cable length must not be altered. The remote mounting bracket is shown below. It has two 0.219" mounting holes designed to accommodate #10 screws. It also has parallel slots that allow for the use of pipe clamps when mounting the enclosure on a stanchion or pipe. The bracket may be used as a template for marking locations for holes.

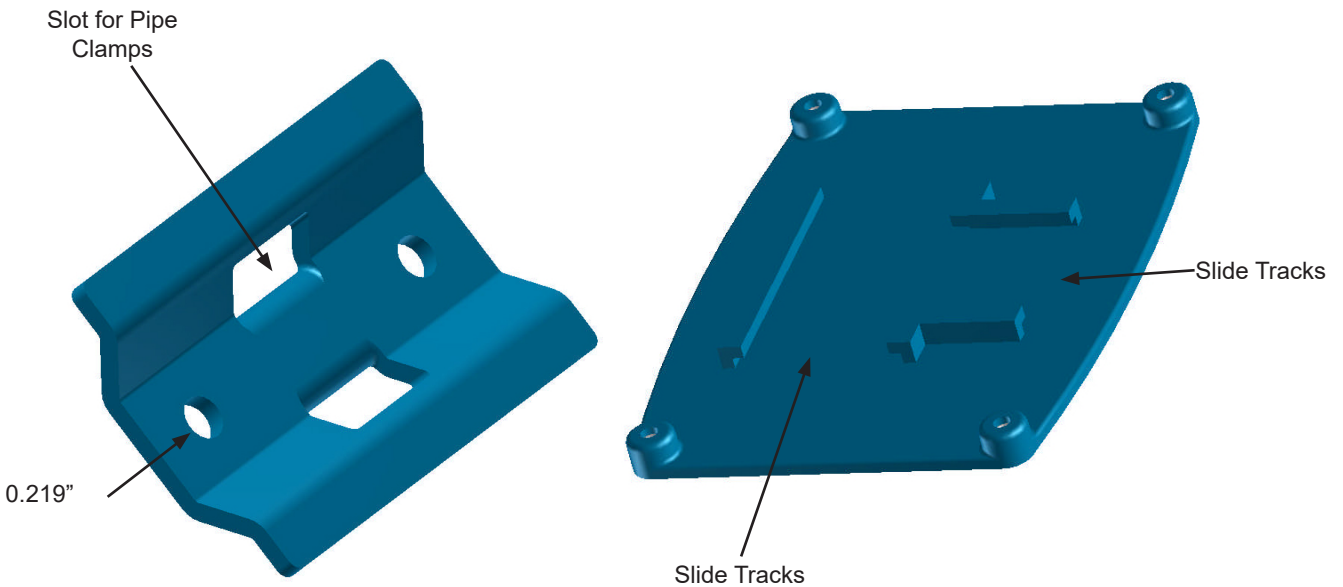

#### IMPORTANT NOTE

Open isolation valves, leak test and purge the piping system of air prior to wiring the meter.

### 3.4 POWER AND SIGNAL WIRING CONNECTIONS

The F-4600 is provided with 4 glands on the right hand side of the enclosure for power and signal cables. Each includes a strain relief for securing the cabling and a sealing cap. The power cable should enter the enclosure through the bottom gland. Do not remove the sealing caps from unused cable glands. To access the wiring connections, remove the 4 cover screws shown below.



Remote (internal) Temperature Sensor		
Name	Terminal #	Description
1000 ohm	TB3-1	RTD signal wire
Not used	TB3-2	No Connection
Not used	TB3-3	No Connection
1000 ohm RTD	TB3-4	RTD signal wire

\* This sensor must be in the same pipe as the flow sensor.

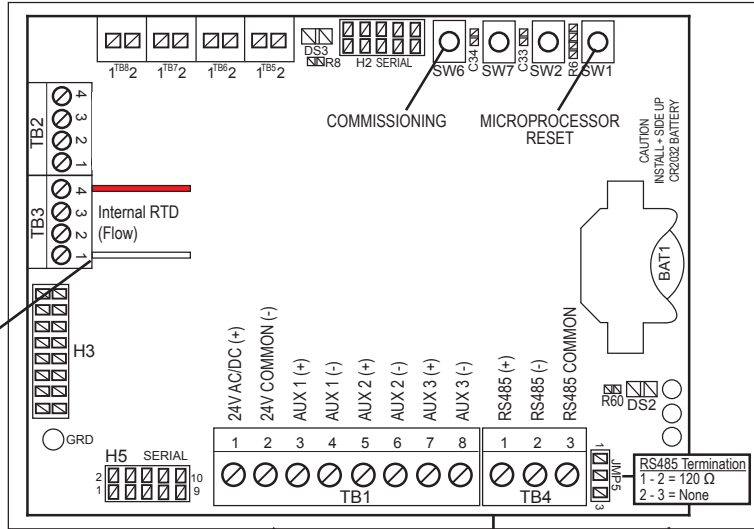

Power and Signal Inputs (18 - 22 AWG wire)		
Name	Terminal #	Description
24V AC/DC (+)	TB1-1	12 - 36 VAC, 50/60 Hz, 5 VA max.
24V AC/DC Common (-)	TB1-2	12-42 VDC, 5 W max.
Aux I/O # 1 (+)	TB1-3	Configured as either input or output at factory.
Aux I/O # 1 (-)	TB1-4	<b>Output rating</b> Pulse Output: Pulse duration: Selectable 50, 100, 500, or 1,000 ms Contact ratings: 50 mA, 30 VDC max.
Aux I/O # 2 (+)	TB1-5	Analog Output (AUX I/O # 3 only): Selectable: 4-20 mA, 0-10 VDC, 0-5 VDC
Aux I/O # 2 (-)	TB1-6	<b>Input rating</b> For use with open collector sinking and dry contact outputs only.
Aux I/O # 3 (+)	TB1-7	Pulse duration: 50 ms min.
Aux I/O # 3 (-)	TB1-8	Sinking Current: 1 mA max.

RS485 Termination Resistor		
Name	JMP5	Description
120 ohm	Position 1	Jumper Position 1 & 2 = 120 ohms
120 ohm	Position 2	
None	Position 3	Jumper Position 2 & 3 = No Termination

RS485 (20 - 24 AWG wire)		
Name	TB4	Description
RS485 B (+)	TB4-1	RS485 Unit Load = 1/4 Recommended Devices per Segment = 32
RS485 A (-)	TB4-2	
RS485 Common	TB4-3	

### 3.4 POWER AND SIGNAL WIRING CONNECTIONS (CONTINUED)



#### WARNING

A short can exist if multiple F-4600 LCD meters are powered by one transformer. This could permanently damage the meters. To avoid this, all of the same legs of the transformer must be connected to all the positive (+) inputs of the meters and the other legs must be connected to all the negative (-) inputs.

If one leg of the transformer is earth grounded, that should be connected to the negative (-) inputs. Refer to the below diagram for an example of a correct hook up.

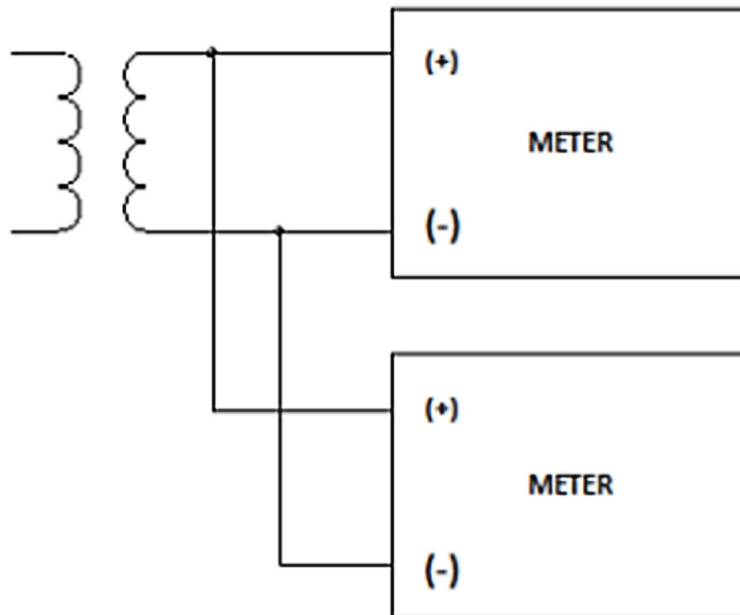

*Correct Connection of Multiple Meters*

## SECTION 4.0: F-4600 START-UP AND COMMISSIONING

### 4.1 START-UP

When power is first applied to the meter the display will be illuminated and the following start screen will appear. Momentarily press SEL (select) to access the operating mode (User Screens) display pages.

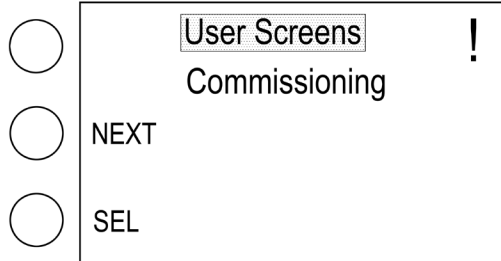

Verify that the meter is functional by stepping through the display pages and confirming the flow rate and temperature data is within expected norms. Momentarily press NEXT or BACK to change the displayed page. A complete list of the display pages is provided on the following page.

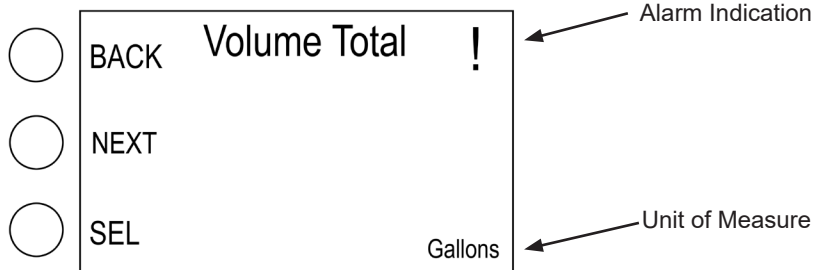

When reviewing the displayed data, note the factory programmed engineering units on each display page (e.g. gallons, gpm, °F). Note any changes that may be necessary. These will need to be made during commissioning.

To return to the commissioning mode from the user screens, momentarily press MENU. The following page will appear. Momentarily press EXIT to return to the start screen.

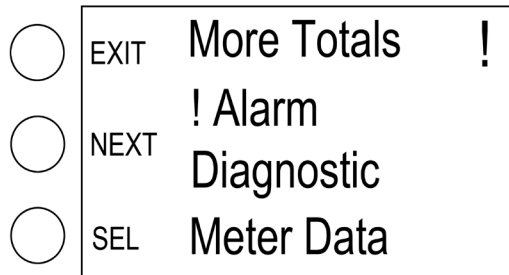

# Operating Mode

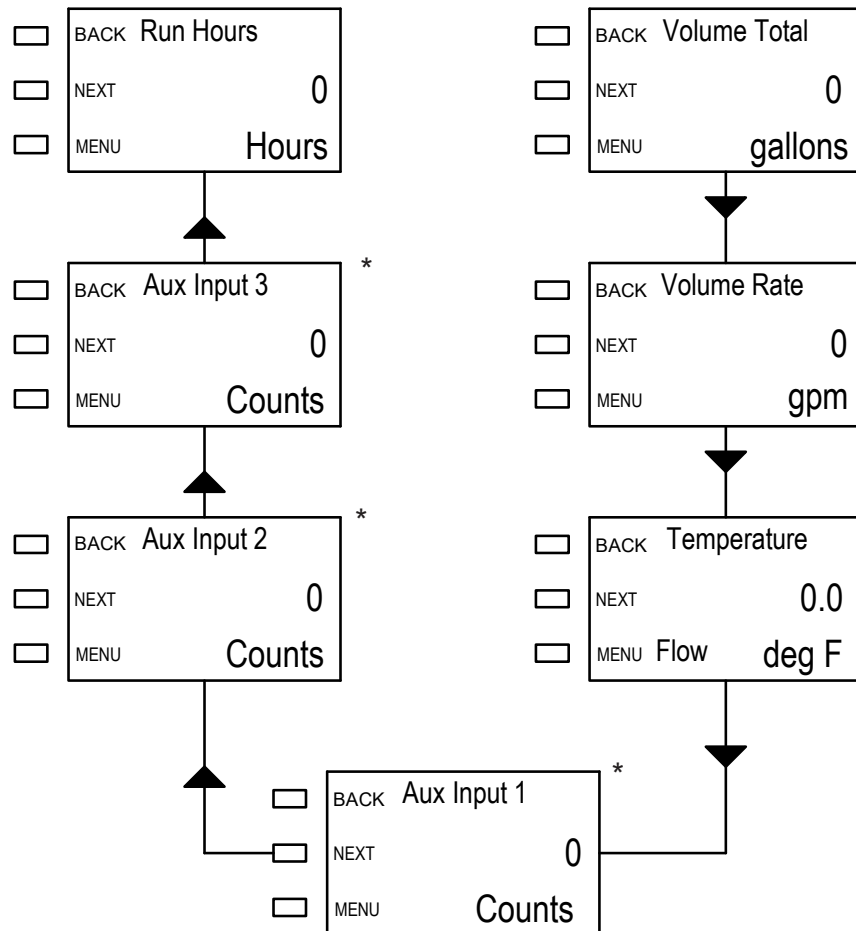

\* Will only appear if Aux I/O was configured at factory for pulse input.



## 4.1.2 Additional Display Pages

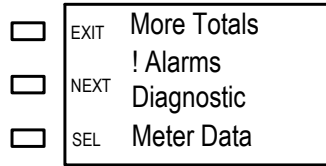

### More Totals

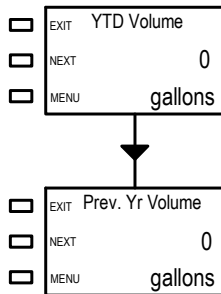

YTD Volume Total resets at  
12:01 AM on January 1st

Prev. Yr Volume Total updates at  
12:01 AM on January 1st

### Diagnostics

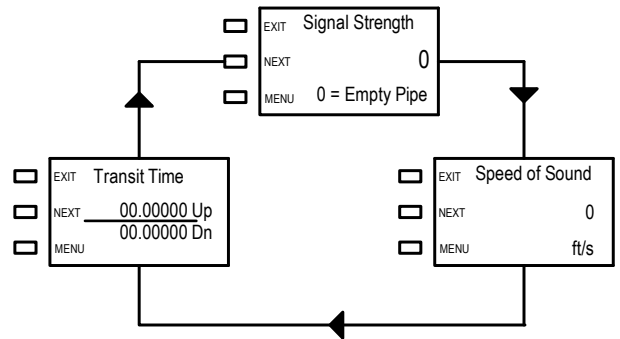

### Meter Data

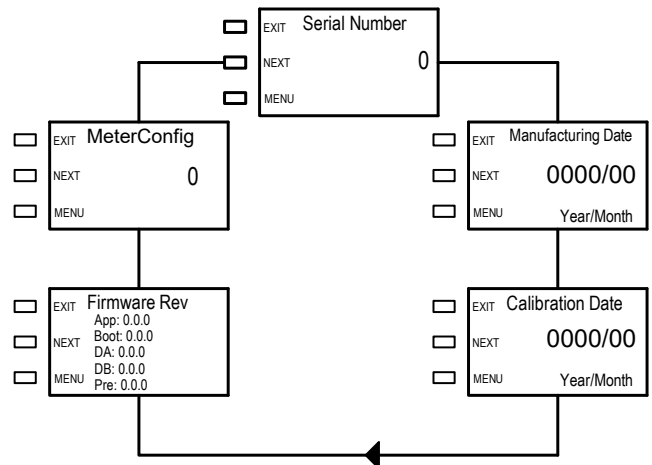

### Alarms

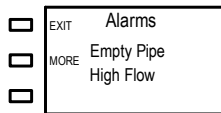

Alarm Messages

High Flow  
Empty Pipe  
Comm error  
System Fault

## 4.2 COMMISSIONING

The last step in the installation process is commissioning the meter. Commissioning is a 2 step process. The first step is to review the mechanical installation to confirm that the flow meter is properly located in the piping system. The second step is a review of the meter program settings. Both steps must be completed in order to finish the installation. A simple commissioning checklist is shown below. A copy of this may be found online at [www.onicon.com/F-4600.html](http://www.onicon.com/F-4600.html).

### Commissioning Checklist

#### Part 1 Mechanical installation

- Confirm that the flow sensor is properly located in the piping system (Sec. 3.1 & 3.2).
- Confirm that the flow sensor is properly oriented with respect to flow direction (Sec. 3.2).

#### Part 2 Programming

- Verify that the Units of Measure Settings in the meter are correct (Sec. 4.1).
- Confirm that there are no alarm indications and the meter is functional (Sec. 4.1.2).

#### 4.2.1 Commissioning Following Initial Power-up

During initial power-up, the following display pages will appear when the commissioning option is selected. The settings shown on the following page allow the installer to set MODBUS® or BACnet® parameters, and the date and time. If the factory pre-programmed engineering units for flow and temperature are correct, press SAVE to exit commissioning once the correct date has been set. Momentarily press NEXT if you wish access the remaining commissioning mode display pages as shown.

Short Commissioning

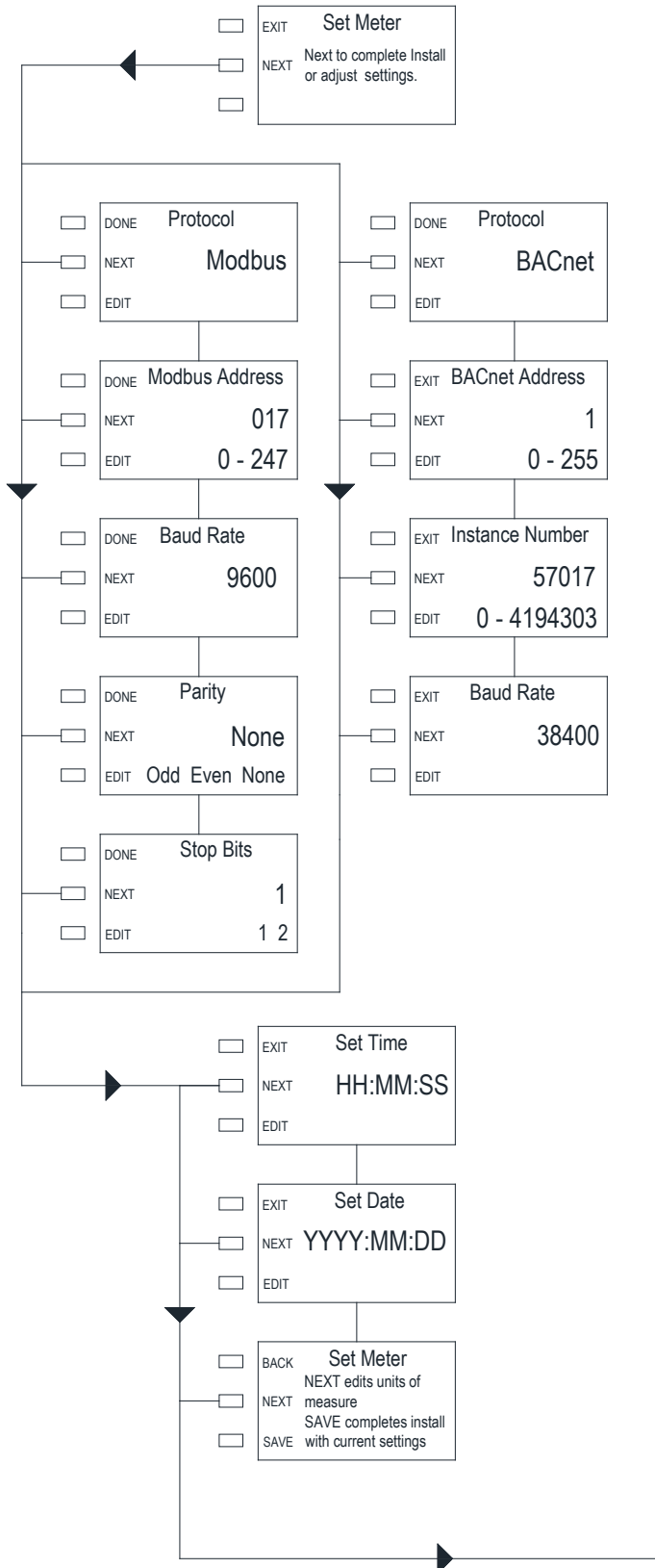

Units of Measure & Aux I/O Configuration Settings

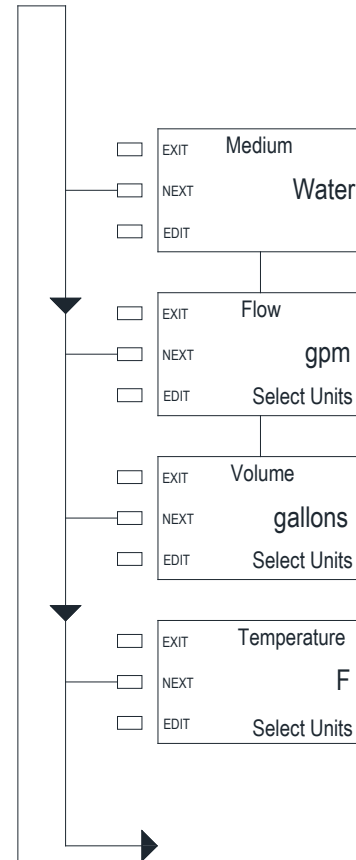

Remaining parameters branch depending on model number. See following pages.

To determine how the auxiliary inputs and outputs are configured on your F-4600, reference the model number string of your meter:

**Meter Model Number Coding = F-4600-AAA-BCD-EFG**

**F = Analog & Pulse Input / Output Configuration (Not field configurable)**

0 = 3 pulse inputs

1 = 3 pulse outputs

2 = 2 pulse inputs & 1 pulse output

3 = 1 pulse input & 2 pulse outputs

4 = 1 analog output & 2 pulse inputs

5 = 1 analog output & 2 pulse outputs

6 = 1 analog output, 1 pulse input & 1 pulse output

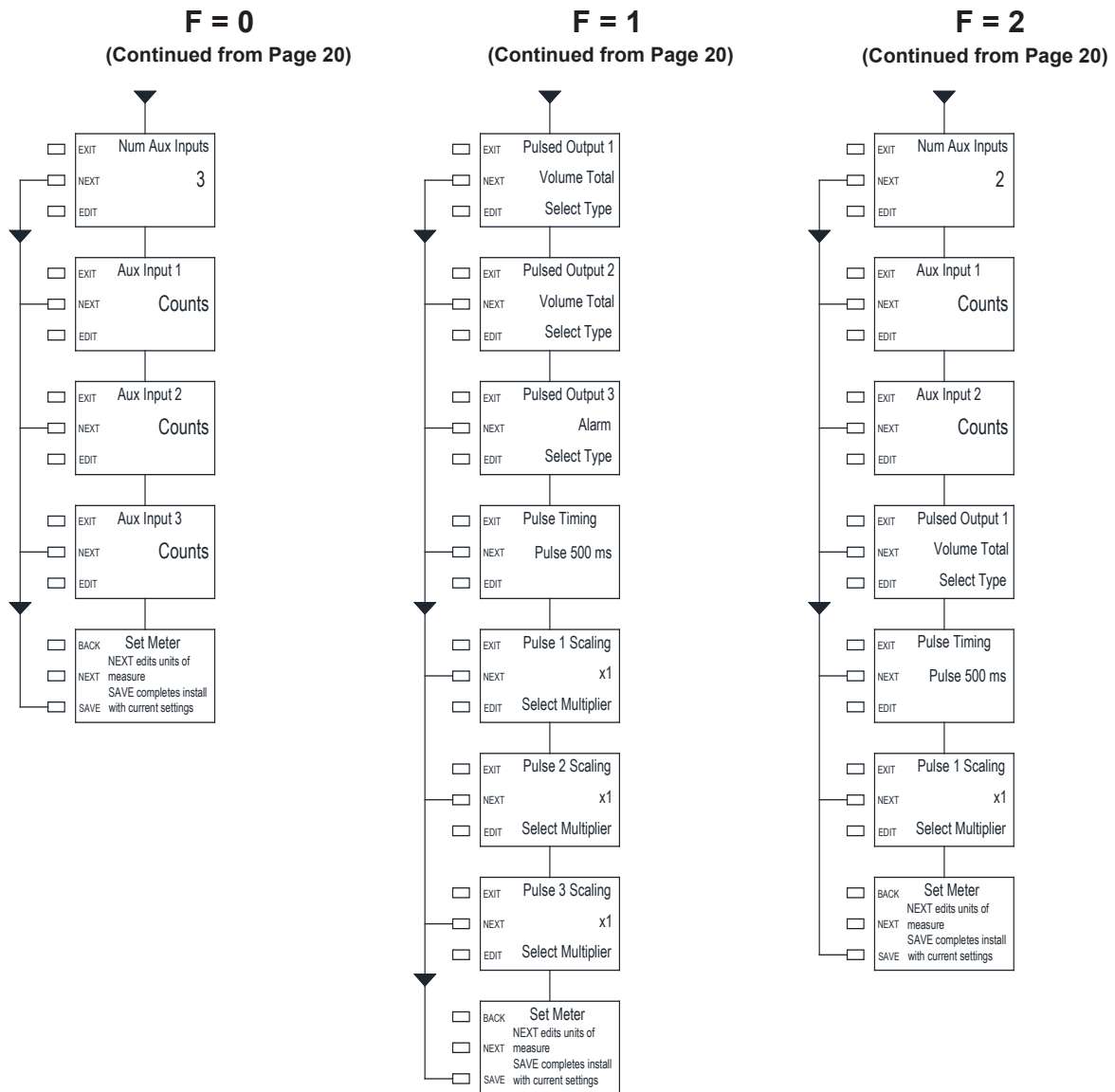

### F = 3

(Continued from Page 20)

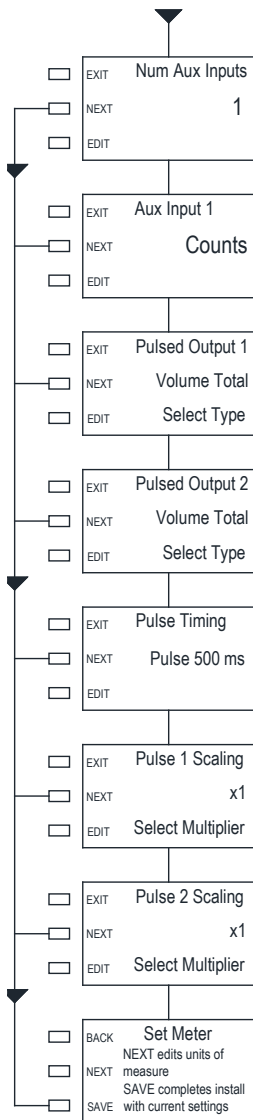

### F = 4

(Continued from Page 20)

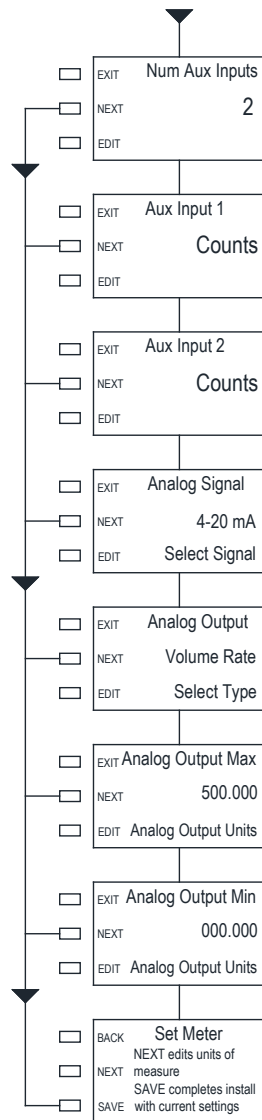

### F = 5

(Continued from Page 20)

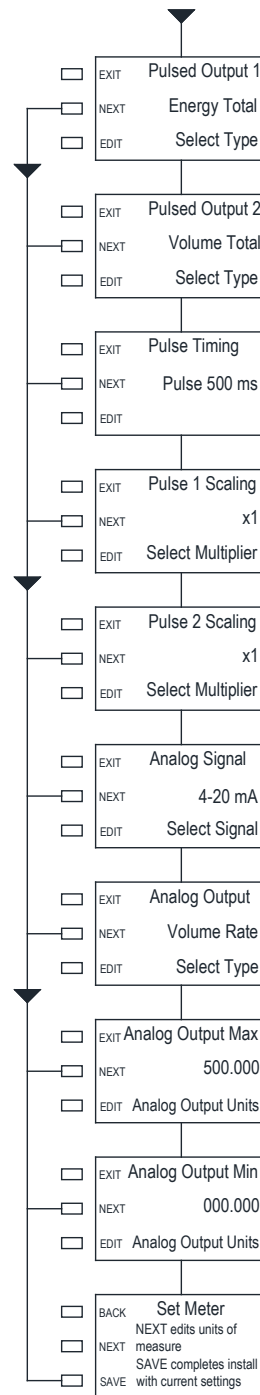

### F = 6

(Continued from Page 20)

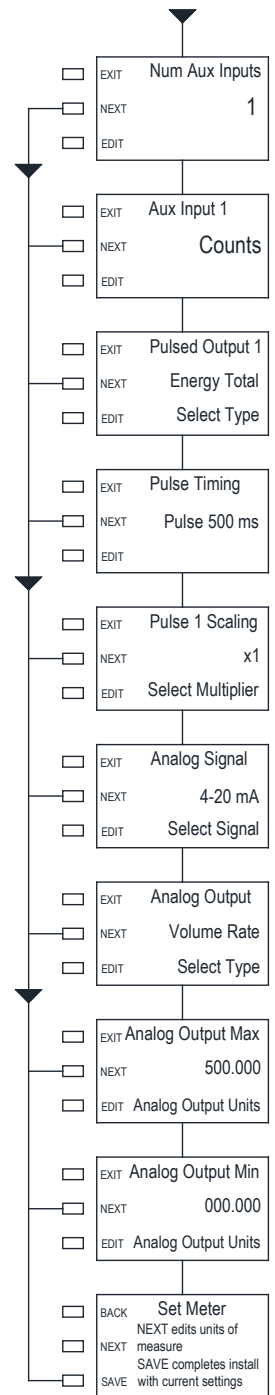

## SECTION 5.0: DIAGNOSTIC FUNCTIONS

The ONICON F-4600 has self diagnostic functions that continually monitor key operating parameters. A list of the alarm messages is shown below.

Displayed Message	Description
System Fault	System Fault is displayed with an error code. This message indicates a hardware malfunction. The meter will not calculate energy in this state.
Reverse Flow	Flow is reversed through the meter. The meter will not calculate energy in this state.
Signal Fault	This is a warning message that the flow signal is weak. It may indicate entrained air in the flow stream.
Empty Pipe	The pipe is empty
Low Flow	The flow reading is below the minimum flow threshold of the meter (e.g. 0.03 gpm for ½" meter). The meter will not calculate energy in this state.
High Flow	This is a warning message that the flow reading is above the maximum flow rate of the meter (e.g. 15 gpm for ½" meter).

## SECTION 6.0: BACNET MS/TP

BACnet® MS/TP, serial interface connections are connected at terminal block TB4.

Transceiver: 2-wire, half-duplex (1/4 unit load)  
BACnet® address (MAC address) range: 1 - 255 (Default: 017)  
Device Instance: 0 - 4,194,303 (Default: 57017)  
Baud rate: 9600, 19200, 38400 or 76800 (Default: 38400)  
Termination: 120 ohms or none (Default: None)  
Biasing: None  
Flow control: None

### 6.1 BACNET® OBJECT TYPES

BACnet® Object Type and Number of Objects Implemented

Device: 1  
Analog Input: 10  
Analog Value: 22  
Binary Value: 10  
Multistate Object: 1  
Trend Log Multiple: 1

### 6.2 PROTOCOL IMPLEMENTATION STATEMENT

BACnet® Protocol Revision: 10  
Device Profile (Annex L): BACnet® Application Specific Controller (B-ASC)  
MS/TP master (Clause 9), baud rate(s): 9600, 19200, 38400 & 76800  
Device Address Binding: No  
BBMD support registration by Foreign Devices: No  
Character Set Supported: ANSI X3.4

BACnet® Interoperability Building Blocks Supported (Annex K):  
Data Sharing - ReadProperty - B (DS-RP-B)  
Data Sharing - ReadProperty Multiple - B (DS-RPM-B)  
Data Sharing - WriteProperty - B (DS-WP-B)  
Data Sharing - WriteProperty Multiple - B (DS-WPM-B)  
Device Management - Dynamic Device Binding - B (DM-DDB-B)  
Device Management - Dynamic Object Binding - B (DM-DOB-B)  
Device Management - DeviceCommunicationControl - B (DM-DCC-B)  
Device Management - Time Synchronization - B (DM-TS-B)  
Device Management - UTC Time Synchronization - B (DM-UTC-B)  
Trending - View and Modify Multiple Values - I - B (T-VMMV-I-B)

Standard Object Types Supported:

Device Object	Binary Value Object
Analog Input Object	Multi-State Value
Analog Value Object	Trend Log Multiple

## 6.3 DEVICE OBJECT

Property	Default Value	Read-only or Writable	Comment
Object Identifier	57017	Writable	0-4,194,303
Object Name	F-4600-BAC	Read-only	
Object Type	Device	Read-only	
System Status	Operational	Read-only	
Vendor Name	ONICON Incorporated	Read-only	
Model Name	F-4600-BAC	Read-only	
Firmware Rev.	000.000.000	Read-only	
Location	Customer Location	Writable	32 char. max
Description	Customer Description	Writable	32 char. max
Protocol Version	1	Read-only	
Protocol Revision	10	Read-only	
Services Supported	Read property, Read property multiple, Write property, Write property multiple, Read range, Who-has, I have, Who-is, I-am, Device communications control, Time synchronization, UTC time synchronization	Read-only	
Object Types Supported	Analog input, Analog value, Binary input, Device, Multi-state value, Trend log multiple	Read-only	
Object List	(Device, 57017), (analog input, 1 – 10), (analog value, 1 – 22), (binary value, 1 – 10), (trend log multiple, 1), (multi state value, 1)	Read-only	
Max ADPU Length	480	Read-only	
Local Time	Device current time	Read-only	
Local Date	Device current date	Read-only	
UTC Offset	-300	Writable	
Daylight Savings Status	False	Writable	
APDU Timeout	6000	Read-only	
# of APDU Retries	3	Writable	
Max Master	127	Read-only	
Device Address Binding		Read-only	
Database Revision	1	Read-only	



## 6.4 ANALOG INPUT(S)

Property	Default Value	Read-only or Writable	Comment
Object Identifier	Analog-input, 1 to analog-input,10	Read-only	
Object Name	Various	Read-only	
Object Type	Analog-input	Read-only	
Present Value	REAL	Writable	
Description	Analog-input, # Name	Read-only	
Status Flags	(F,F,F,F)	Read-only	
Event State	Normal	Read-only	
Reliability	No-fault-detected	Read-only	
Out-of-Service	FALSE	Writable	
Update interval	100	Read-only	
Units	Various	Read-only	
Min-Present-Value	-1000000000	Read-only	
Max-Present-Value	1000000000	Read-only	
Resolution	0.000001	Read-only	

Analog Input Objects	
Object Identifier	Function
Analog Input 1	Energy rate (Not used)
Analog Input 2	Volume rate
Analog Input 3	Supply internal temperature
Analog Input 4	Return temperature (Not used)
Analog Input 5	Delta temperature (Not used)
Analog Input 6	Signal strength
Analog Input 7	Signal quality
Analog Input 8	Speed of sound
Analog Input 9	Peak energy rate (Not used)
Analog Input 10	Average delta temp (Not used)

### BACnet Engineering Units for Analog Inputs (Defaults)

Energy rate: **Not available**

Volume rate: **gpm**, l/s, ft3/m or m3/h

Temperature: °F or °C

Signal strength: No units (0 - 100 counts)

Signal quality: No units (3 - 31 counts, 3 = best)

Speed of sound: **ft/s** or m/s

## 6.5 ANALOG VALUE(S)

Property	Default Value	Read-only or Writable	Comment
Object Identifier	Analog-value, 1 to analog-value,22	Read-only	
Object Name	Various	Read-only	
Object Type	Analog-value	Read-only	
Present Value	REAL	Writable	
Description	Analog-value, # Name	Read-only	
Status Flags	(F,F,F,F)	Read-only	
Event State	Normal	Read-only	
Reliability	No-fault-detected	Read-only	
Out-of-Service	FALSE	Writable	
Units	Various	Read-only	
Priority Array	{NULL, NULL, NULL, NULL, NULL, NULL, NULL, NULL, NULL, NULL, NULL, NULL}	Read-only	
Relinquish Default	0	Read-only	

Analog Value Objects		
Object Identifier	Single Mode Function	Dual Mode Function
Analog Value 1 (Not used)	Energy total	Mode 1 energy total
Analog Value 2 (Not used)	Energy total	Mode 2 energy total
Analog Value 3 (Not used)	Y-T-D energy total	Y-T-D mode 1 energy total
Analog Value 4 (Not used)	Y-T-D energy total	Y-T-D mode 2 energy total
Analog Value 5 (Not used)	Previous year energy total	Previous year mode 1 energy total
Analog Value 6 (Not used)	Previous year energy total	Previous year mode 2 energy total
Analog Value 7 (Not used)	User defined energy total	User mode 1 energy total
Analog Value 8 (Not used)	User defined energy total	User mode 2 energy total
Analog Value 9	Volume total	Mode 1 volume total
Analog Value 10	Volume total	Mode 2 volume total
Analog Value 11	Y-T-D volume total	Y-T-D mode 1 volume total
Analog Value 12	Y-T-D volume total	Y-T-D mode 2 volume total
Analog Value 13	User defined volume total	User mode 1 volume total
Analog Value 14	User defined volume total	User mode 2 volume total
Analog Value 15	Aux pulse input 1 total	Aux pulse input 1 total
Analog Value 16	Aux pulse input 2 total	Aux pulse input 2 total
Analog Value 17	Aux pulse input 3 total	Aux pulse input 3 total
Analog Value 18	Run hours	Run hours
Analog Value 19 (Not used)	Incremental energy total	Incremental energy total mode 1
Analog Value 20 (Not used)	Incremental energy total	Incremental energy total mode 2

Analog Value 21*	Incremental volume total	Incremental volume total mode 1
Analog Value 22*	Incremental volume total	Incremental volume total mode 2
Analog Value 23	Previous year volume total	Previous year mode 1 volume total
Analog Value 24	Previous year volume total	Previous year mode 2 volume total

\* Time interval set by Trend Log Object

### BACnet Engineering Units for Analog Values (Defaults)

Energy: Not Available

Volume: **gallons**, liters, ft<sup>3</sup> or m<sup>3</sup>

Auxiliary pulse inputs: **No units** (counts)

Run hours: **Hours**

## 6.6 BINARY VALUE(S)

Property	Default Value	Read-only or Writable	Comment
Object Identifier	Binary-value, 1 to binary-value, 10	Read-only	
Object Name	Various	Read-only	
Object Type	Binary-value	Read-only	
Present Value	0	Writable	
Description	Binary-value, # Name	Read-only	
Status Flags	(F,F,F,F)	Read-only	
Event State	Normal	Read-only	
Reliability	No-fault-detected	Read-only	
Out-of-Service	FALSE	Writable	
Elapsed Active Time	Various	Read-only	
Priority Array	(NULL, NULL, NULL, NULL, NULL, NULL, NULL, NULL, NULL, NULL, NULL, NULL)	Read-only	
Relinquish Default	0	Read-only	

### Binary Value Objects

Object Identifier	Description	Notes
Binary Value 1 (Not used)	Mode indication	0 = mode 1, 1 = mode 2
Binary Value 2 (Not used)	Location	0 = supply, 1 = return
Binary Value 3 (Not used)	User defined energy total reset, mode 1	1 = reset total
Binary Value 4 (Not used)	User defined energy total reset, mode 2	1 = reset total
Binary Value 5	User defined volume total reset, mode 1	1 = reset total
Binary Value 6	User defined volume total reset, mode 2	1 = reset total
Binary Value 7	Aux input 1 total reset	1 = reset total
Binary Value 8	Aux input 2 total reset	1 = reset total
Binary Value 9	Aux input 3 total reset	1 = reset total
Binary Value 10	Flow direction	1 = reverse flow

## 6.7 MULTI STATE VALUE

Property	Default Value	Read-only or Writable	Comment
Object Identifier	Multi-state-value, 1	Read-only	
Object Name	Meter Status	Read-only	
Object Type	Multi-state-value	Read-only	
Present Value	1	Writable	
Description	Multi-state-value, # Name	Read-only	
Status Flags	(F,F,F,F)	Read-only	
Event State	Normal	Read-only	
Reliability	No-fault-detected	Read-only	
Out-of-Service	FALSE	Writable	
Number of States	11	Read-only	
State Text	Normal, Low Supply Temperature, High Supply Temperature, Low Return Temperature, Delta T < Minimum, High Energy Rate, Low Signal Quality, Comm Error, Low Supply Voltage, System Fault	Read-only	
Relinquish Default	0	Read-only	

### Multi-state Object

Object Identifier	Description	Notes
Multi-state Value 1	<p>Reports the operating status of the meter</p> <ul style="list-style-type: none"> <li>1 = Normal</li> <li>2 = Low Supply Temperature</li> <li>3 = High Supply Temperature</li> <li>4 = Low Return Temperature</li> <li>5 = High Return Temperature</li> <li>6 = Delta T &lt; Minimum</li> <li>7 = High Energy Rate</li> <li>8 = Low Signal Quality</li> <li>9 = Comm error</li> <li>10 = Low Supply Voltage</li> <li>11 = System Fault</li> </ul>	Numeric values indicate meter status.

## 6.8 TREND LOG MULTIPLE

Property	Default Value	Read-only or Writable
Object Identifier	Trend log multiple 1	Read-only
Object Name	Log Data	Read-only
Object Type	Trend log multiple	Read-only
Description	Trend log multiple, # Name	Read-only
Status Flags	(F,F,F,F)	Read-only
Event State	Normal	Read-only
Reliability	No-fault-detected	Read-only
Enable	TRUE	Writable
Log Device Property		Read-only
Logging Type	POLLED	Read-only
Log Interval	90000	Writable
Stop When Full	FALSE	Read-only
Buffer Size	480	Read-only
Log Buffer		Read-only
Record Count	0	Writable
Total Record Count	0	Read-only

Trend Log Multiple Object		
Object Identifier	Description	Notes
Trend Log Multiple 1	Logs the following BACnet objects: Peak energy rate Average delta temp Incremental energy total mode 1* Incremental energy total mode 2* Incremental volume total mode 1 Incremental volume total mode 2 Meter status (multi-state object)	The log buffer holds 120 records and then rolls over with the first in as first out. The logging interval can be set from 30 seconds to 1 hour via BACnet. The default interval is 15 minutes.

\* No data available with F-4600-BAC

## SECTION 7.0: MODBUS

MODBUS® serial interface connections are connected at terminal block TB4.

Transceiver: 2-wire, half-duplex (1/4 unit load)

MODBUS® Address Range: 1 - 247 (Default: 017)

Data Format: 8 bit

Stop Bits: 1

Parity: None (Default), Odd, or Even

Byte Order: ABCD

Baud Rate: 4800, 9600, 19200, 38400, 57600, 76800 or 115200 (Default: 9600)

Termination: Jumper selectable 120Ω resistor (See page 15)

Biasing: None

Engineering Units	Abbreviation	Engineering Units	Abbreviation
<b>Volume Rate (Flow)</b>		<b>Volume Total</b>	
Gallons per minute	GPM	Gallons	Gal
Liters per second	L/s	Liters	Liters
Cubic feet per minute	ft <sup>3</sup> /min	Cubic Feet	ft <sup>3</sup>
Cubic meters per hour	m <sup>3</sup> /hr	Cubic Meters	m <sup>3</sup>
<b>Temperature</b>			
Degrees Fahrenheit	°F		
Degrees Celsius	°C		
<b>Velocity (Flow velocity, Fluid speed of sound)</b>			
Feet per second	ft/s		
Meters per second	m/s		

Function Codes Supported:
01 - Read Coil(s)
02 - Read Discreet Input(s)
03 - Read Holding Register(s)
04 - Read Input Register(s)
05 - Write Single Coil
06 - Write Single Register
08 - Diagnostic
15 - Write Multiple Coils
16 - Write Multiple Registers
17 - Report Slave ID

## 7.1 MODBUS MEMORY MAP

Register Address	Description	Register Type	Data Range	Over Range	Read/Write	Comments
4	Reset User Defined Volume Total	Coil	NA	NA	Read/Write	Turn coil ON (1) to reset total on F-4600 Turn coil to OFF (0)once reset is complete
7	Reset Aux Input Total - Input 1	Coil	NA	NA	Read/Write	Turn coil ON (1) to reset total on F-4600 Turn coil to OFF (0)once reset is complete
8	Reset Aux Input Total - Input 2	Coil	NA	NA	Read/Write	Turn coil ON (1) to reset total on F-4600 Turn coil to OFF (0)once reset is complete
9	Reset Aux Input Total - Input 3	Coil	NA	NA	Read/Write	Turn coil ON (1) to reset total on F-4600 Turn coil to OFF (0)once reset is complete
10	Reset Aux Input Total - All Inputs	Coil	NA	NA	Read/Write	Turn coil ON (1) to reset total on F-4600 Turn coil to OFF (0)once reset is complete
11	Aux Output 1	Coil	NA	NA	Read/Write	Turn coil ON (1) to latch Aux I/O # 1 closed. Turn coil to OFF (0) to latch I/O # 1 open. Aux I/O # 1 must have been configured as an output at the factory, and programmed for "MODBUS Coil" in the commissioning menu.
12	Aux Output 2	Coil	NA	NA	Read/Write	Turn coil ON (1) to latch Aux I/O # 2 closed. Turn coil to OFF (0) to latch I/O # 2 open. Aux I/O # 2 must have been configured as an output at the factory, and programmed for "MODBUS Coil" in the commissioning menu.
13	Aux Output 3	Coil	NA	NA	Read/Write	Turn coil ON (1) to latch Aux I/O # 3 closed. Turn coil to OFF (0) to latch I/O # 3 open. Aux I/O # 3 must have been configured as an output at the factory, and programmed for "MODBUS Coil" in the commissioning menu.

Register Address	Description	Register Type	Register Type	Comments
30009	Volume Rate - GPM	Input Register	Floating Point Register (1 of 2)	
30010	Volume Rate - GPM	Input Register	Floating Point Register (2 of 2)	
30011	Volume Rate - L/s	Input Register	Floating Point Register (1 of 2)	
30012	Volume Rate - L/s	Input Register	Floating Point Register (2 of 2)	
30013	Volume Rate - ft <sup>3</sup> /min	Input Register	Floating Point Register (1 of 2)	
30014	Volume Rate - ft <sup>3</sup> /min	Input Register	Floating Point Register (2 of 2)	
30015	Volume Rate - m <sup>3</sup> /hr	Input Register	Floating Point Register (1 of 2)	
30016	Volume Rate - m <sup>3</sup> /hr	Input Register	Floating Point Register (2 of 2)	
30017	Flow Temperature - °F	Input Register	Floating Point Register (1 of 2)	Temperature measured by RTD in flow meter
30018	Flow Temperature - °F	Input Register	Floating Point Register (2 of 2)	Temperature measured by RTD in flow meter
30019	Flow Temperature - °C	Input Register	Floating Point Register (1 of 2)	Temperature measured by RTD in flow meter
30020	Flow Temperature - °C	Input Register	Floating Point Register (2 of 2)	Temperature measured by RTD in flow meter
30029	Signal Strength (No units)	Input Register	Floating Point Register (1 of 2)	Range = 1-31; 1 is highest signal strength; 31 is lowest signal strength
30030	Signal Strength (No units)	Input Register	Floating Point Register (2 of 2)	Range = 1-31; 1 is highest signal strength; 31 is lowest signal strength
30031	Signal Quality (No units)	Input Register	Floating Point Register (1 of 2)	
30032	Signal Quality (No units)	Input Register	Floating Point Register (2 of 2)	
30033	Speed of Sound - ft/sec	Input Register	Floating Point Register (1 of 2)	Measured speed of sound of the fluid in the pipe
30034	Speed of Sound - ft/sec	Input Register	Floating Point Register (2 of 2)	Measured speed of sound of the fluid in the pipe
30035	Speed of Sound - m/sec	Input Register	Floating Point Register (1 of 2)	Measured speed of sound of the fluid in the pipe
30036	Speed of Sound - m/sec	Input Register	Floating Point Register (2 of 2)	Measured speed of sound of the fluid in the pipe

30157	Volume Total - Gal	Input Register	Floating Point Register (1 of 2)	
30158	Volume Total - Gal	Input Register	Floating Point Register (2 of 2)	
30159	Volume Total - Liters	Input Register	Floating Point Register (1 of 2)	
30160	Volume Total - Liters	Input Register	Floating Point Register (2 of 2)	
30161	Volume Total - ft <sup>3</sup>	Input Register	Floating Point Register (1 of 2)	
30162	Volume Total - ft <sup>3</sup>	Input Register	Floating Point Register (2 of 2)	
30163	Volume Total - m <sup>3</sup>	Input Register	Floating Point Register (1 of 2)	
30164	Volume Total - m <sup>3</sup>	Input Register	Floating Point Register (2 of 2)	
30181	Year to Date Volume Total - Gal	Input Register	Floating Point Register (1 of 2)	
30182	Year to Date Volume Total - Gal	Input Register	Floating Point Register (2 of 2)	
30183	Year to Date Volume Total - Liters	Input Register	Floating Point Register (1 of 2)	



30184	Year to Date Volume Total - Liters	Input Register	Floating Point Register (2 of 2)	
30185	Year to Date Volume Total - ft <sup>3</sup>	Input Register	Floating Point Register (1 of 2)	
30186	Year to Date Volume Total - ft <sup>3</sup>	Input Register	Floating Point Register (2 of 2)	
30187	Year to Date Volume Total - m <sup>3</sup>	Input Register	Floating Point Register (1 of 2)	
30188	Year to Date Volume Total - m <sup>3</sup>	Input Register	Floating Point Register (2 of 2)	
30205	Previous Year Volume Total - Gal	Input Register	Floating Point Register (1 of 2)	
30206	Previous Year Volume Total - Gal	Input Register	Floating Point Register (2 of 2)	
30207	Previous Year Volume Total - Liters	Input Register	Floating Point Register (1 of 2)	
30208	Previous Year Volume Total - Liters	Input Register	Floating Point Register (2 of 2)	
30209	Previous Year Volume Total - ft <sup>3</sup>	Input Register	Floating Point Register (1 of 2)	
30210	Previous Year Volume Total - ft <sup>3</sup>	Input Register	Floating Point Register (2 of 2)	
30211	Previous Year Volume Total - m <sup>3</sup>	Input Register	Floating Point Register (1 of 2)	
30212	Previous Year Volume Total - m <sup>3</sup>	Input Register	Floating Point Register (2 of 2)	
30229	User Defined Volume Total - Gal	Input Register	Floating Point Register (1 of 2)	
30230	User Defined Volume Total - Gal	Input Register	Floating Point Register (2 of 2)	
30231	User Defined Volume Total - Liters	Input Register	Floating Point Register (1 of 2)	
30233	User Defined Volume Total - ft <sup>3</sup>	Input Register	Floating Point Register (1 of 2)	
30234	User Defined Volume Total - ft <sup>3</sup>	Input Register	Floating Point Register (2 of 2)	
30235	User Defined Volume Total - m <sup>3</sup>	Input Register	Floating Point Register (1 of 2)	
30236	User Defined Volume Total - m <sup>3</sup>	Input Register	Floating Point Register (2 of 2)	
30253	Auxiliary Pulse Input Count- Input 1	Input Register	Floating Point Register (1 of 2)	Unitless count. Value is representative of the total number of pulses received on input.
30254	Auxiliary Pulse Input Count- Input 1	Input Register	Floating Point Register (2 of 2)	Unitless count. Value is representative of the total number of pulses received on input.
30255	Auxiliary Pulse Input Count- Input 2	Input Register	Floating Point Register (1 of 2)	Unitless count. Value is representative of the total number of pulses received on input.
30256	Auxiliary Pulse Input Count- Input 2	Input Register	Floating Point Register (2 of 2)	Unitless count. Value is representative of the total number of pulses received on input.
30257	Auxiliary Pulse Input Count- Input 3	Input Register	Floating Point Register (1 of 2)	Unitless count. Value is representative of the total number of pulses received on input.
30258	Auxiliary Pulse Input Count- Input 3	Input Register	Floating Point Register (2 of 2)	Unitless count. Value is representative of the total number of pulses received on input.
30259	Run Hours	Input Register	Floating Point Register (1 of 2)	
30260	Run Hours	Input Register	Floating Point Register (2 of 2)	
30261	Meter Status	Input Register	Short Integer Register	0 Normal 7 Low Signal Quality 8 Comm error 9 Low Supply Voltage 10 System Fault

## 7.2 DIAGNOSTIC FUNCTION CODE

The MODBUS implementation of the F-4600 supports the use of function code 08, Diagnostic.

When using function code 08, you must also specify the “sub-function” code when sending the message to the F-4600.

The following sub-functions are supported by the F-4600:

Sub-function Code		Name
Hex	Decimal	
00	00	Return Query Data
01	01	Restart Communications Option
04	04	Force Listen Only Mode
0B	11	Return Bus Message Count*
0C	12	Return Bus Communication Error Count*
0D	13	Return Bus Exception Error Count*
0E	14	Return Server Message Count <sup>1</sup>
0F	15	Return Server No Response Count <sup>1</sup>
11	17	Return Server Busy Count <sup>1</sup>
12	18	Return Bus Character Overrun Count <sup>1</sup>

\* Count available in F-4600 diagnostic menu page 1.

<sup>1</sup> Count available in F-4600 diagnostic menu page 2.

### Description of Sub-functions:

#### 00 Return Query Data

The data passed to the F-4600 in the request data field is to be returned (looped back) in the response. The entire response message should be identical to the request.

#### 01 Restart Communications Option

The F-4600 serial line port will be initialized and restarted, and all of its communications event counters are cleared. If the port is currently in Listen Only Mode, no response is returned. This function is the only one that brings the port out of Listen Only Mode. If the port is not currently in Listen Only Mode, a normal response is returned. This occurs before the restart is executed.

#### 04 Force Listen Only Mode

Forces the F-4600 to its Listen Only Mode for MODBUS communications. This isolates it from the other devices on the network, allowing them to continue communicating without interruption from the addressed F-4600. No response is returned. When the remote device enters its Listen Only Mode, all active communication controls are turned off. The Ready watchdog timer is allowed to expire, locking the controls off. While the device is in this mode, any MODBUS messages addressed to it or broadcast are monitored, but no actions will be taken and no responses will be sent.

The only function that will be processed after the mode is entered will be the Restart Communications Option function (function code 8, sub-function 1).

### **11 (0B Hex) Return Bus Message Count**

The response data field from the F-4600 returns the quantity of messages that it has detected on the communications system since its last restart, restart communications option, or power-up.

This count is also available in the F-4600's diagnostic menu page.

### **12 (0C Hex) Return Bus Communication Error Count**

The response data field returns the quantity of CRC errors encountered by the F-4600 since its last restart, restart communications option, or power-up.

This count is also available in the F-4600's diagnostic menu page.

### **13 (0D Hex) Return Bus Exception Error Count**

The response data field returns the quantity of MODBUS exception responses returned by the F-4600 since its last restart, restart communications option, or power-up.

This count is also available in the F-4600's diagnostic menu page.

### **14 (0E Hex) Return Server Message Count**

The response data field returns the quantity of messages addressed to the F-4600, or broadcast, that the F-4600 has processed since its last restart, restart communications option, or power-up.

This count is also available in the F-4600's diagnostic menu page.

### **15 (0F Hex) Return Server No Response Count**

The response data field returns the quantity of messages addressed to the F-4600 for which it has returned no response (neither a normal response nor an exception response), since its last restart, restart communications option, or power-up.

This count is also available in the F-4600's diagnostic menu page.

### **17 (11 Hex) Return Server Busy Count**

The response data field returns the quantity of messages addressed to the F-4600 for which it returned a Server Device Busy exception response, since its last restart, restart communications option, or power-up.

This count is also available in the F-4600's diagnostic menu page.

### **18 (12 Hex) Return Bus Character Overrun Count**

The response data field returns the quantity of messages addressed to the F-4600 that it could not handle due to a character overrun condition, since its last restart, restart communications option, or power-up. A character overrun is caused by data characters arriving at the port faster than they can be stored, or by the loss of a character due to a hardware malfunction.

This count is also available in the F-4600's diagnostic menu page.

## **7.3 REPORT SLAVE ID FUNCTION CODE**

The MODBUS implementation of the F-4600 supports the use of function code 17, Report Slave ID.

When a message is sent to the F-4600 requesting to report the slave ID, the following information is returned:

F-4600-XXXXXX; where XXXXXX - serial number of the F-4600

The F-4600 will report data in decimal or HEX, depending on the control system settings. The data must be converted from decimal/HEX to ASCII in order to form the string.

## SECTION 8.0: AUXILIARY INPUTS AND OUTPUTS

### 8.1 DETERMINING AUXILIARY INPUT AND OUTPUT CONFIGURATION

The ONICON F-4600 can be configured from the factory to provide a variety of auxiliary input and output configurations. Once configured at the factory, the function of the auxiliary terminal cannot be changed. However, how the input is described on the LCD display, or how the output is programmed, can be changed in the field during the commissioning process.

To determine how the auxiliary inputs and outputs are configured on your F-4600, reference the model number string of your meter:

#### **Meter Model Number Coding = F-4600-AAA-BCD-EF**

F = Analog & Pulse Input / Output Configuration  
(Not field configurable)

0 = 3 pulse inputs

1 = 3 pulse outputs

2 = 2 pulse inputs & 1 pulse output

3 = 1 pulse input & 2 pulse outputs

4 = 1 analog output & 2 pulse inputs

5 = 1 analog output & 2 pulse outputs

6 = 1 analog output, 1 pulse input & 1 pulse output

### 8.2 AUXILIARY INPUTS

When configured with auxiliary pulse inputs, your F-4600 will be equipped with the ability to bring in local dry contact and open collector pulses to be displayed on the F-4600 LCD screen as well as the (RS485) output.

#### **Input Rating:**

For use with open collector sinking and dry contact pulse outputs only.

Pulse Duration – 50 ms minimum

Sinking Current – 1 mA maximum

The default LCD page description for each auxiliary input is “Counts.” This is because each pulse is a count of an accumulated value from the remote device. The F-4600 allows for the user to change this description through the commissioning process. To repeat the commissioning process after it has already been completed once, please follow the steps in Appendix 2.

It is important to understand that the local aux input description on the F-4600 only appears on the LCD display. The value transmitted over the (RS485) network will be a unitless count regardless of the description programmed into the F-4600. The MODBUS memory map, which describes the register locations for the aux input count and the coils to reset them to zero, are located in section 7.1.

## 8.3 AUXILIARY OUTPUTS

When configured with auxiliary pulse outputs, your F-4600 will be equipped with the ability to send contact closure pulses for use with a remote totalizer or building automation system.

### Output Rating:

Contact closure output.

Pulse Duration – Selectable 50 ms, 100 ms, 500 ms (default), or 1,000 ms

Contact rating – 50 mA, 30 VDC maximum

If the F-4600 is configured with pulse outputs, the displayed total menu pages that correspond to each pulse output will indicate the pulse output number and the scaling for the pulse output. The engineering unit associated with the displayed total will also apply to the pulse output. Both the function of the pulse output, as well as the scaling, can be changed during the commissioning process. To repeat the commissioning process after it has already been completed, please follow the steps in Appendix 2.

### 8.3.1 Pulse Outputs

The following pulse outputs are available from the F-4600:

**Total Volume** - Units match LCD totalizer. Output can be scaled for 1, 10, or 100.

Example: if configured for 10, the meter will require 10 LCD display accumulations before a pulse output is provided.

**Alarm** - Latching output. The output will remain open when the meter is not in alarm, and will latch closed when the meter is in alarm. A list of alarms can be found in section 5.0, Diagnostic Functions.

**MODBUS Coil** - Latching output. The output will remain open when the MODBUS coil associated with the auxiliary terminal is inactive, and the output will latch shut when the coil is activated. The MODBUS memory map which describes the registers associated with the coils, and how to use them, is described in Section 7.1, MODBUS Memory Map.

## 8.4 ANALOG OUTPUT

When configured with an auxiliary analog output, your F-4600 with optional LCD display will be equipped with the ability to send a single analog signal to a remote device or building automation system. The analog output can be programmed in the commissioning menu for 4-20 mA, 0-5 V, or 0-10 V output types. The factory default is 4-20 mA. To repeat the commissioning process after it has already been completed once, please follow the steps in Appendix 2.

The following meter values are available to be mapped to the analog output:

Volume Rate  
Fluid Temperature

The analog output minimum and maximum are also configured in the commissioning menu. The minimum value set in programming will be what the 4 mA or 0 V is equivalent to. The maximum value set in programming will be what the 20 mA/5 V/10 V is equivalent to.

**Example:** A 4-20 mA analog output configured as fluid temperature with a minimum of 30 and maximum of 80 will have an output signal of  
4-20 mA = 30 - 80° F.

The units of measurement for the analog output will match the LCD description on the F-4600. When cycling through the F-4600 run pages, if the F-4600 is equipped with an analog output, the page which corresponds to the analog output will have the output signal type and scaling shown on it.

## **APPENDIX A**

**A-1 F-4600 FLOW WIRING DIAGRAM**

**A-2 CHANGING BACNET SETTINGS OR METER PROGRAMMING AFTER COMMISSIONING**

**A-3 SELECTING THE RIGHT METER & CALCULATING PRESSURE LOSS**

# F-4600 WIRING DIAGRAM



Flow (internal) Temperature Sensor*		
Name	Terminal #	Description
1000 ohm	TB2-1	RTD signal wire
Not used	TB2-2	No Connection
Not used	TB2-3	No Connection
1000 ohm RTD	TB2-4	RTD signal wire

\* This sensor must be in the same pipe as the flow sensor.

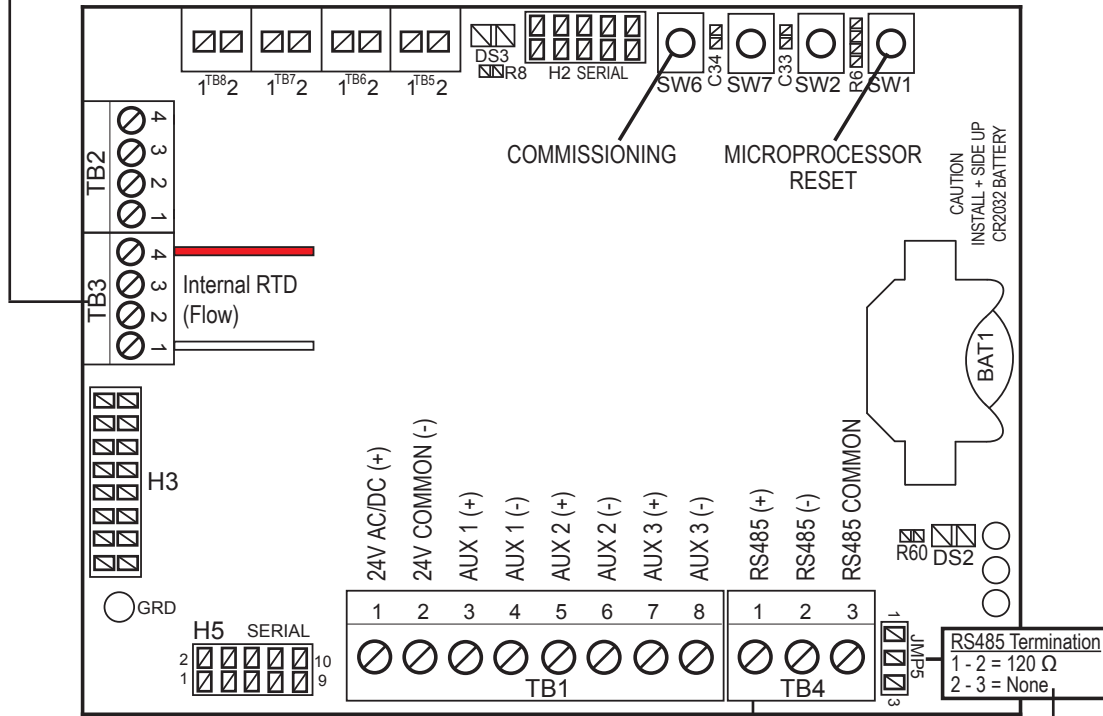

Power and Signal Inputs (18 - 22 AWG wire)		
Name	Terminal #	Description
24V AC/DC (+)	TB1-1	12 - 36 VAC, 50/60 Hz, 5 VA max. 12-42 VDC, 5 W max.
24V AC/DC Common (-)	TB1-2	
Aux I/O # 1 (+)	TB1-3	Configured as either input or output at factory. <b>Output rating</b> Pulse Output: Pulse duration: Selectable 50, 100, 500, or 1,000 ms Contact ratings: 50 mA, 30 VDC max. Analog Output (AUX I/O # 3 only): Selectable: 4-20 mA, 0-10 VDC, 0-5 VDC <b>Input rating</b> For use with open collector sinking and dry contact outputs only. Pulse duration: 50 ms min. Sinking Current: 1 mA max.
Aux I/O # 1 (-)	TB1-4	
Aux I/O # 2 (+)	TB1-5	
Aux I/O # 2 (-)	TB1-6	
Aux I/O # 3 (+)	TB1-7	
Aux I/O # 3 (-)	TB1-8	

RS485 Termination Resistor		
Name	JMP5	Description
120 ohm	Position 1	Jumper Position 1 & 2 = 120 ohms
120 ohm	Position 2	
None	Position 3	Jumper Position 2 & 3 = No Termination

RS485 (20 - 24 AWG wire)		
Name	TB4	Description
RS485 B (+)	TB4-1	RS485 Unit Load = 1/4 Recommended Devices per Segment = 32
RS485 A (-)	TB4-2	
RS485 Common	TB4-3	



# CHANGING (RS485) SETTINGS OR METER PROGRAMMING AFTER COMMISSIONING



(RS485) settings and meter programming can be changed after commissioning is complete. In order to accomplish this it will be necessary to re-open the enclosure (Refer to section 3.4). Once the cover is open locate the commissioning button.

Briefly press COMMISSIONING once to re-enter the (RS485) and date/time settings menu shown below. Press the DONE button at any time to save changes and exit.

To re-enter the units of measure setting menu pages shown below, press and hold the COMMISSIONING button for 5 seconds. Press DONE button at any time to save the changes and exit.

## Short Commissioning

## Units of Measure & Aux I/O Configuration Settings

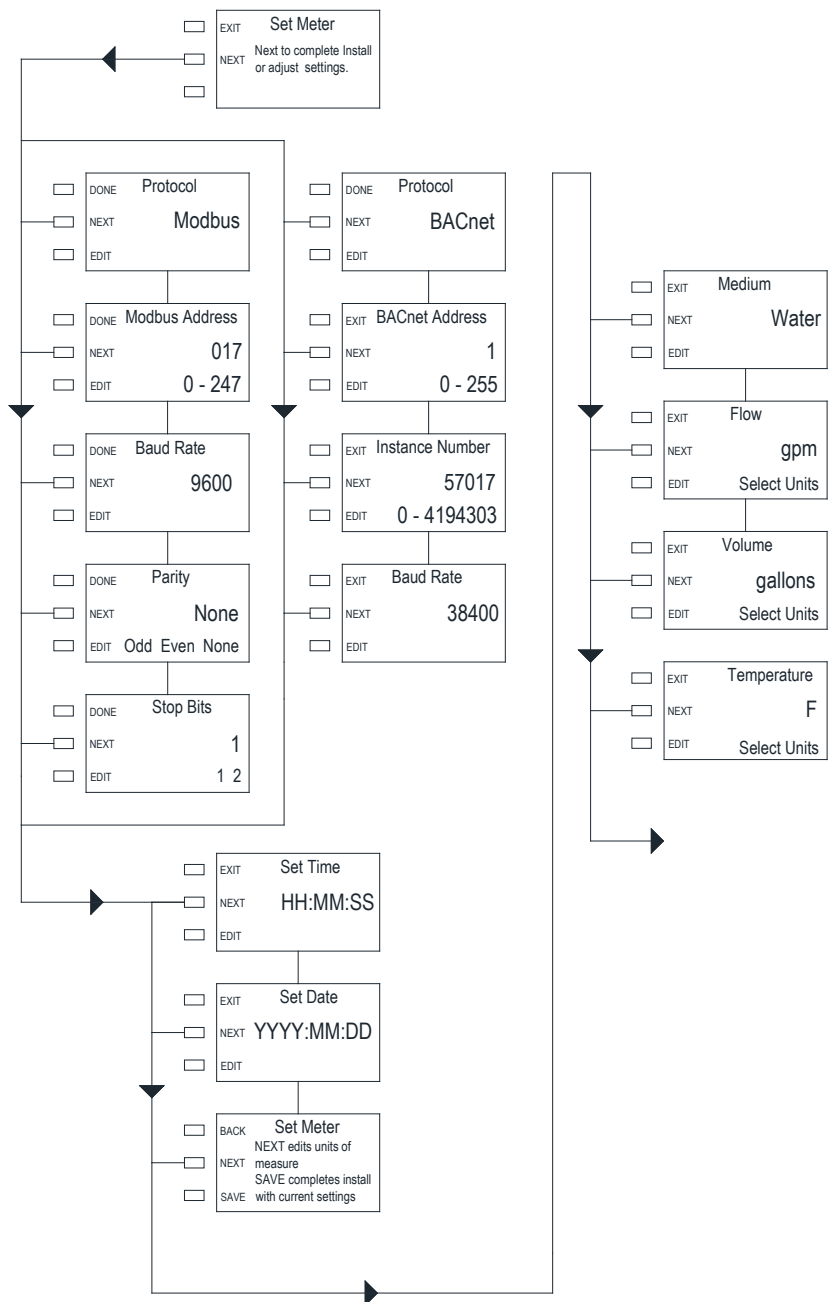

# SELECTING THE RIGHT METER & CALCULATING PRESSURE LOSS



For optimum performance, meters should be selected by the process connection size and expected design\* flow rate for the application. In some cases ONICON offers more than one flow rate range option based on the process connection size. The following information is provided to assist in selecting the most appropriate meter size for your application.

1. Select the preferred process connection size.
2. Review the design flow rate and maximum flow rate for the meter you have selected. Where more than one choice is available, choose the meter that most closely matches your expected design flow rate with the meter's stated design flow rate.
3. If your design flow rate is significantly higher than that of the meter you have chosen, determine the pressure drop for your design flow rate using the chart below and confirm that it is acceptable for your application. If necessary, select a meter with a larger process connection size to achieve an acceptable pressure drop for your application.

Meter Size	Process Connection Type	Typical Design Flow	1% of Rate Flow Range	2% of Rate Flow Range	Minimum Flow	C <sub>v</sub>
(Nominal)	(Nominal)	(gpm)	(gpm)	(gpm)	(gpm)	(gpm)
½"	Male NPT	6.6	0.6 – 15	0.15 – 15	0.03	6.08
¾"	Male NPT	6.6	0.6 – 15	0.15 – 15	0.03	6.08
¾" (high flow)	Male NPT	11	1 – 25	0.25 – 25	0.05	8.81
1"	Male NPT	11	1 – 25	0.25 – 25	0.05	8.81
1" (high flow)	Male NPT	15.4	1.4 – 35	0.35 – 35	0.07	12.17
1¼"	Male NPT	26.4	3 – 60	0.6 – 60	0.12	36.95
1½"	Male NPT	44	5 – 100	1 – 100	0.2	51.20
2"	Male NPT	66	8 – 150	1.5 – 150	0.3	101.2
2½"	Class 150 Flange	110	12 - 225	2.5 - 250	0.5	156.2

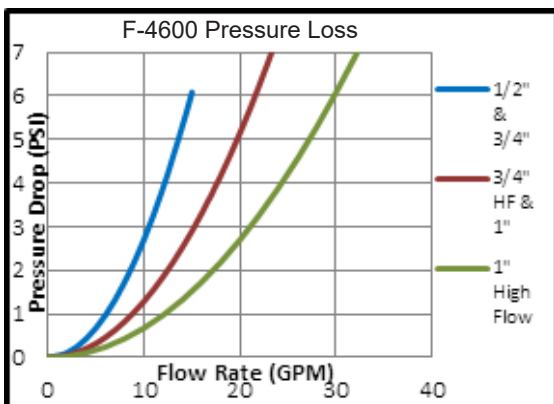

$$\Delta p = \left( \frac{Q}{C_v} \right)^2$$

Where: Q = Flow Rate (GPM)  
 C<sub>v</sub> = Flow Coefficient  
 Δp = Pressure Loss (PSI)

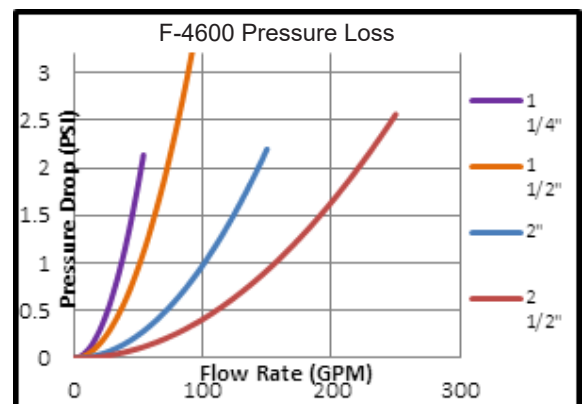

\*ONICON defines the “design” flow rate as the maximum continuous flow expected by the application under normal operating conditions. The pressure drop for ONICON design flow rates is ≤1.7 psi.