

F-2600 & F-2700 Series Vortex Flow Meter Installation and Operation Guide



SAFETY INFORMATION

This meter was calibrated at the factory before shipment. To ensure correct use of the meter, please read this manual thoroughly.

Regarding this Manual:

- This manual should be passed on to the end user.
- Before use, read this manual thoroughly to comprehend its contents.
- The contents of this manual may be changed without prior notice.
- All rights reserved. No part of this manual may be reproduced in any form without ONICON's written permission.
- ONICON makes no warranty of any kind with regard to this material, including, but not limited to, implied warranties of merchantability and suitability for a particular purpose.
- All reasonable effort has been made to ensure the accuracy of the contents of this manual. However, if any errors are found, please inform ONICON.
- ONICON assumes no responsibilities for this product except as stated in the warranty.
- If the customer or any third party is harmed by the use of this product, ONICON assumes no responsibility for any such harm owing to any defects in the product which were not predictable, or for any indirect damages.

Safety Precautions:

The following general safety precautions must be observed during all phases of installation, operation, service, and repair of this product. Failure to comply with these precautions or with specific WARNINGS given elsewhere in this manual violates safety standards of design, manufacture, and intended use of the product. ONICON Incorporated assumes no liability for the customer's failure to comply with these requirements. If this product is used in a manner not specified in this manual, the protection provided by this product may be impaired.

The following symbols are used in this manual:



WARNING

Messages identified as WARNING contain information regarding the personal safety of individuals involved in the installation, operation or service of this product.



CAUTION

Messages identified as CAUTION contain information regarding the potential damage to the product or other ancillary products.



IMPORTANT NOTICE

Messages identified as IMPORTANT NOTICE contain information critical to the proper operation of the product.

WARNINGS AND CAUTIONS



WARNING

Consult the flow meter nameplate for specific flow meter approvals before any hazardous location installation.

Hot tapping must be performed by a trained professional. U.S. regulations often require a hot tap permit. The manufacturer of the hot tap equipment and/or the contractor performing the hot tap is responsible for providing proof of such a permit.

All flow meter connections, isolation valves and fittings for cold/hot tapping must have the same or higher pressure rating as the main pipeline.

For F-2700 series insertion flow meter installations, an insertion tool must be used for any installation where a flow meter is inserted under pressure greater than 50 psig.

To avoid serious injury, DO NOT loosen a compression fitting under pressure.

To avoid potential electric shock, follow National Electric Code or your local code when wiring this unit to a power source. Failure to do so could result in injury or death. All AC power connections must be in accordance with published CE directives. All wiring procedures must be performed with the power Off.

Before attempting any flow meter repair, verify that the line is not pressurized. Always remove main power before disassembling any part of the mass flow meter.



CAUTION

Calibration must be performed by qualified personnel. ONICON Incorporated, strongly recommends that you return your flow meter to the factory for calibration.

In order to achieve accurate and repeatable performance, the flow meter must be installed with the specified minimum length of straight pipe upstream and downstream of the flow meter's sensor head.

When using toxic or corrosive gases, purge the line with inert gas for a minimum of four hours at full gas flow before installing the flow meter.

For F-2700 series insertion flow meter installations, the sensor alignment pointer must point downstream in the direction of flow.

The AC wire insulation temperature rating must meet or exceed 85° C (185° F)

Customer Notice for Oxygen Service

Unless you have specifically ordered ONICON's optional O² cleaning, this flow meter may not be fit for oxygen service. Some models can only be properly cleaned during the manufacturing process. ONICON Incorporated is not liable for any damage or personal injury, whatsoever, resulting from the use of ONICON Incorporated's standard mass flow meters for oxygen gas.

Specific Conditions of Use (ATEX/IECEX)

Contact Manufacturer regarding Flame path information.

Clean with a damp cloth to avoid any build-up of electrostatic charge.

The Model F-2600, and F-2700 Vortex Flowmeters standard temperature option (0) process temperature range is -40°C to 260°C. The high temperature option (1) process temperature range is -40°C up to +400°C.

F-2600 / F-2700 Vortex Flow Meters		
Tmax (Process)	Temperature Class Value (Gas)	
	T Version	H Version
80°C	T6	85°C
95°C	T5	100°C
130°C	T4	135°C
195°C	T3	200°C
260°C	T2	300°C
400°C	N/A	405°C

No part of this publication may be copied or distributed, transmitted, transcribed, stored in a retrieval system, or translated into any human or computer language, in any form or by any means, electronic, mechanical, manual, or otherwise, or disclosed to third parties without the express written permission of ONICON Incorporated. The information contained in this manual is subject to change without notice.

TABLE OF CONTENTS

1.0	INTRODUCTION	11
1.1	F-2600 & F-2700 Series Vortex Mass Flow Meters	11
1.1.1	Using this Manual	11
1.1.2	Receipt of System Components	12
1.1.3	Technical Assistance	12
1.2	How the ONICON Vortex Meter Operates	13
1.2.1	Velocity Measurement	13
1.2.2	Vortex Shedding Frequency	14
1.2.3	Vortex Frequency Sensing	14
1.2.4	Flow Velocity Range	15
1.2.5	Temperature Measurement	16
1.2.6	Pressure Measurement	16
1.3	Flow Meter Configurations	17
1.3.1	Multivariable Options	17
1.3.2	Line Size / Process Conditions / Materials	18
1.3.3	Flow Meter Electronics	18
2.0	INSTALLATION	19
2.1	Installation Overview	19
2.1.1	Flow Meter Installation Requirements	19
2.1.2	Recommended Meter Locations	20
2.1.3	Unobstructed Flow Requirements	21
2.2	F-2600 Series Inline Flow Meter Installation	22
2.2.1	Wafer-Style Flow Meter Installation	23
2.2.2	Flange-Style Flow Meter Installation	24
2.3	F-2700 Series Insertion Flow Meter Installation	25
2.3.1	Standard Installation Guidelines	26
2.3.2	Hot Tap Guidelines	27
2.4	Flow Meter Insertion	28
2.4.1	Installing Meters with a Packing Gland Connection	29
2.4.2	Insertion Procedure with Permanent Insertion Tool	30
2.4.3	Insertion Procedure with Removable Insertion Tool	31
2.4.4	Installing Meters (Packing Gland), No Insertion Tool	32
2.4.5	Insertion Procedure for flow meters with no Insertion Tool	33
2.5	Adjusting Meter Orientation	34
2.5.1	Display/Keypad Adjustment	34
2.5.2	Enclosure Adjustment	35

2.6	Loop-Power Flow Meter Wiring Connections	36
2.6.1	Input Power Connections	36
2.6.2	4-20 mA Output Connections	37
2.6.3	Pulse Output Connections.....	38
2.6.4	Frequency Output Connections	39
2.6.5	Optional Backlight Connections	39
2.6.6	Remote Electronics Wiring.....	40
2.7	High Power Flow Meter Wiring Connections.....	42
2.7.1	Input Power Connections	41
2.7.2	4-20 mA Output Connections	44
2.7.3	Frequency Output Connections	45
2.7.4	Pulse Output Connections.....	46
2.7.5	Alarm Output Connections	48
2.7.6	Remote Electronics Wiring.....	49
2.7.7	Optional Input Electronics Wiring.....	50
2.7.8	Optional Energy EMS RTD Input Wiring.....	50
2.7.9	Optional External 4-20 mA Input Wiring	51
2.7.10	Optional Contact Closure Input Wiring.....	52
3.0	OPERATING INSTRUCTIONS.....	54
3.1	Flow Meter Display/Keypad	54
3.2	Start-Up.....	55
3.3	Using the Setup Menus	57
3.3.1	Programming the Flow Meter.....	58
3.3.2	Output Menu	59
3.3.3	Display Menu	61
3.3.4	Alarm Menu	62
3.3.5	Totalizer #1 Menu.....	63
3.3.6	Totalizer #2 Menu.....	64
3.3.7	Energy Menu.....	65
3.3.8	Fluid Menu	66
3.3.9	Units Menu	67
3.3.10	Time and Date Menu	68
3.3.11	Diagnostics Menu	69
3.3.12	Calibration Menu.....	70
3.3.13	Password Menu.....	71

4.0	SERIAL COMMUNICATIONS.....	72
4.1	HART Communications	72
4.1.1	Wiring.....	72
4.1.2	HART Commands with the DD Menu	74
4.1.3	HART Commands with Generic DD Menu.....	79
4.2	MODBUS Communications.....	82
4.2.1	Wiring.....	82
4.2.2	Menu Items	83
4.2.3	Register Definitions	85
4.3	BACnet	91
4.3.1	BACnet MS/TP Description	91
4.3.2	Baud Rate on the MS/TP Bus.....	91
	4.3.2.1 Baud Rate and MAC address configuration.....	91
4.3.3	Supported BACnet Objects.....	91
	4.3.3.1 Device Object	93
	4.3.3.2 Analog Input Object.....	93
	4.3.3.3 Binary Input Object	95
4.3.4	Acronyms and Definitions	99
5.0	TROUBLESHOOTING AND REPAIR.....	100
5.1	Hidden Diagnostics Menus	101
5.1.1	Level One Hidden Diagnostics Values.....	102
5.1.2	Level Two Hidden Diagnostics Values.....	103
5.2	Analog Output Calibration	104
5.3	Troubleshooting the Flow Meter.....	105
5.4	First Check Items	105
5.5	Record Values	105
5.6	Determine the Fault.....	106
5.6.1	Symptom: Output at No Flow.....	106
5.6.2	Symptom: Erratic Output	106
5.6.3	Symptom: No Output	108
5.6.4	Symptom: Meter Displays Temperature Fault.....	109
5.6.5	Symptom: Meter Displays Pressure Fault.....	110
5.7	Electronics Assembly Replacement (All Meters).....	111
5.8	Pressure Sensor Replacement (Inline Only)	112
5.9	Returning Equipment to the Factory.....	112
A-1	APPENDIX A PRODUCT SPECIFICATIONS	
B-1	APPENDIX B APPROVALS	
C-1	APPENDIX C FLOW METER CALCULATIONS	
D-1	APPENDIX D GLOSSARY	

FIGURES

1	Inline Vortex Multi-Parameter Mass Flow Meter	13
2	Measurement Principle of Vortex Flow Meters	14
3	Reynolds Number Range of the Meter	16
4	Recommended Pipe Length Required for Installation	21
5	Flange Bolt Tightening Sequence.....	22
6	Wafer-Style Flow Meter Installation	23
7	Flange-Style Flow Meter Installation.....	24
8	Isolation Valve Requirements.....	25
9	Hot Tap Sequence	27
10	Insertion Calculation (Meters with Insertion Tool)	29
11	Flow Meter with Permanent Insertion Tool.....	30
12	Flow Meter with Removable Insertion Tool	31
13	Insertion Calculation (Meters without Insertion Tool).....	32
14	Display/Keypad Viewing Adjustment	34
15	Enclosure Viewing Adjustment.....	35
16	Loop-Power Wiring Terminals for Loop Powered Version	36
17	DC Power Connections	37
18	Load Resistance Versus Input Voltage	37
19	Isolated Pulse Output Using External Power Supply	38
20	Non-Isolated Pulse Output Using External Power Supply	38
21	Isolated Frequency Output Using External Power Supply	39
22	Non-Isolated Frequency Output Using External Power Supply	39
23	Backlight Using External Power Supply.....	39
24	Loop-Power Volumetric Flow Meter Junction Box	40
25	Loop-Power Mass Flow Meter Junction Box	41
26	AC Wiring Terminals	42
27	AC Power Connections.....	42
28	DC Wiring Terminals	43
29	DC Power Connections	43
30	Load Resistance Versus Input Voltage	44
31	Isolated 4-20 Output Using External Power Supply	44
32	Non-Isolated 4-20 Output Using Input Power Supply	45
33	Isolated 4-20 Output Using Meter Power Supply (AC only)	45
34	Isolated Frequency Output Using External Power Supply	46
35	Non-Isolated Frequency Output Using Input Power Supply.....	46
36	Isolated Frequency Output Using Meter Power Sup. (AC only).....	46
37	Isolated Pulse Output Using External Power Supply	47

38	Non-Isolated Pulse Output Using Input Power Supply	47
39	Isolated Pulse Output Using Meter Power Supply (AC only).....	47
40	Isolated Alarm Output Using External Power Supply	48
41	Non-Isolated Alarm Output Using Meter Power Supply	48
42	Isolated Alarm Output Using Meter Power Supply (AC only)	48
43	High Power Flow Meter Junction Box	49
44	Optional Energy EMS RTD Input Wiring.....	50
45	External 4-20 mA Input Wiring – External Power Supply.....	51
46	External 4-20 mA Input Wiring – DC Powered Meter.....	51
47	External 4-20 mA Input Wiring – AC Powered Meter.....	52
48	Optional External Contact Closure Input Wiring	52
49	Flow Meter Display/Keypad	54
50	Loop-Powered Meter Wiring (HART)	72
51	DC Powered Meter Wiring (HART).....	73
52	AC Powered Meter Wiring (HART).....	73
53	RS-485 Wiring (MODBUS)	82
54	Electronics Stack Sensor Connections.....	107
55	Remote Feed Through Board Sensor Connections.....	107
56	Vortex Sensor Connector	108
57	Temperature Sensor Connector	109
58	Pressure Sensor Connector.....	110

TABLES

1	Minimum Recommended Stud Bolt Lengths	22
2	Byte Order (MODBUS)	84
3	Register Definitions (MODBUS).....	86

SECTION 1.0: INTRODUCTION

1.1 ONICON F-2600 & F-2700 SERIES VORTEX MASS FLOW METERS

The ONICON F-2600 Series Inline and F-2700 Series Insertion Vortex Flow Meters provide a reliable solution for process flow measurement. From a single entry point in the pipeline, F-2600 meters offer precise measurements of mass or volumetric flow rates.

Multi-Parameter Mass Flow Meters

Mass flow meters utilize three primary sensing elements: a vortex shedding velocity sensor, an RTD temperature sensor, and a solid state pressure sensor to measure the mass flow rate of gases, liquids, and steam.

Meters are available as loop powered devices or with up to three 4-20 mA analog output signals for monitoring your choice of the five process variables (mass flow, volumetric flow, temperature, pressure and fluid density). The Energy Monitoring option permits real-time calculation of energy consumption for a facility or process.

Volumetric Flow Meters

The primary sensing element of a volumetric flow meter is a vortex shedding velocity sensor. Meters are loop powered. The analog 4-20 mA output signal offers your choice of volumetric or mass flow rate. Mass flow rate is based on a constant value for fluid density stored in the instrument's memory.

Both the mass and volumetric flow meters can be ordered with a local keypad/display which provides instantaneous flow rate, total, and process parameters in engineering units. A pulse output signal for remote totalization and BACnet MS/TP, MODBUS RTU RS485 or HART communications are also available. Digital electronics allow for easy reconfiguration for most gases, liquids and steam. ONICON meters' simple installation combines with an easy-to-use interface that provides quick set up, long term reliability and accurate mass flow measurement over a wide range of flows, pressures and temperatures.

1.1.1 Using This Manual

This manual provides information needed to install and operate both the F-2600 Inline and F-2700 insertion style flow meters.

Section 1 includes the introduction and product description.

Section 2 provides information needed for installation.

Section 3 describes system operation and programming.

Section 4 provides information on HART, MODBUS and BACnet protocols.

Section 5 covers troubleshooting and repair.

Appendix A - Product Specifications

Appendix B- Flow Meter Calculations

Appendix C – Glossary of Terms

1.1.2 Receipt of System Components

When receiving an ONICON mass flow meter, carefully check the outside packing carton for damage incurred in shipment. If the carton is damaged, notify the local carrier and submit a report to the factory or distributor. Remove the packing slip and check that all ordered components are present. Make sure any spare parts or accessories are not discarded with the packing material. Do not return any equipment to the factory without first contacting ONICON Customer Service.

1.1.3 Technical Assistance

If you encounter a problem with your flow meter, review the configuration information for each step of the installation, operation and set up procedures. Verify that your settings and adjustments are consistent with factory recommendations. Refer to Section 5, Troubleshooting, for specific information and recommendations.

If the problem persists after following the troubleshooting procedures outlined in Section 5, contact ONICON Incorporated Technical Support at +1 (727) 447-6140 between 8:00 a.m. and 5:00 p.m. EST. When calling Technical Support, have the following information on hand:

The serial number and model number (shown on the meter nameplate)
The problem you are encountering and any corrective action taken
Application information (fluid, pressure, temperature and piping configuration)

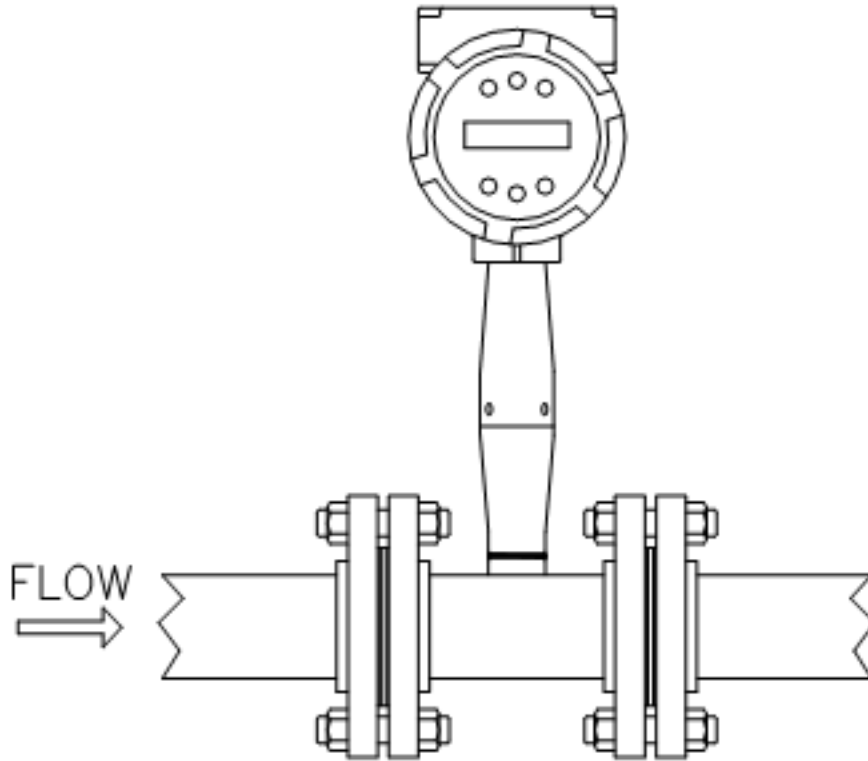

Figure 1. In-Line Multi-Parameter Vortex Mass Flow Meter

ONICON F-2600 Series & F-2700 Series Vortex Mass Flow Meters use a unique sensor head to monitor mass flow rate by directly measuring three variables: fluid velocity, temperature and pressure. The built-in flow computer calculates the mass flow rate and volumetric flow rate based on these three direct measurements. The sensing head is built into the vortex meter's flow body. To measure fluid velocity, the flow meter incorporates a bluff body (shedder bar) in the flow stream and measures the frequency of vortices created by the shedder bar. Temperature is measured using a platinum resistance temperature detector (PRTD). Pressure measurement is achieved using a solid-state pressure transducer. All three elements are combined into an integrated sensor head assembly located downstream of the shedder bar within the flow body.

1.2.1 Velocity Measurement

ONICON's vortex velocity sensor is a patented mechanical design that minimizes the effects of pipeline vibration and pump noise, both of which are common error sources in flow measurement with vortex flow meters. The velocity measurement is based on the well-known Von Karman vortex shedding phenomenon. Vortices are shed from a shedder bar, and the vortex velocity sensor located downstream of the shedder bar senses the passage of these vortices. This method of velocity measurement has many advantages including inherent linearity, high turndown, reliability and simplicity.

1.2.2 Vortex Shedding Frequency

Von Karman vortices form downstream of a shedder bar into two distinct wakes. The vortices of one wake rotate clockwise while those of the other wake rotate counterclockwise. Vortices generate one at a time, alternating from the left side to the right side of the shedder bar. Vortices interact with their surrounding space by over-powering every other nearby swirl on the verge of development. Close to the shedder bar, the distance (or wave length) between vortices is always constant and measurable. Therefore, the volume encompassed by each vortex remains constant, as shown below. By sensing the number of vortices passing by the velocity sensor, the F-2600 & F-2700 Flow Meter computes the total fluid volume.

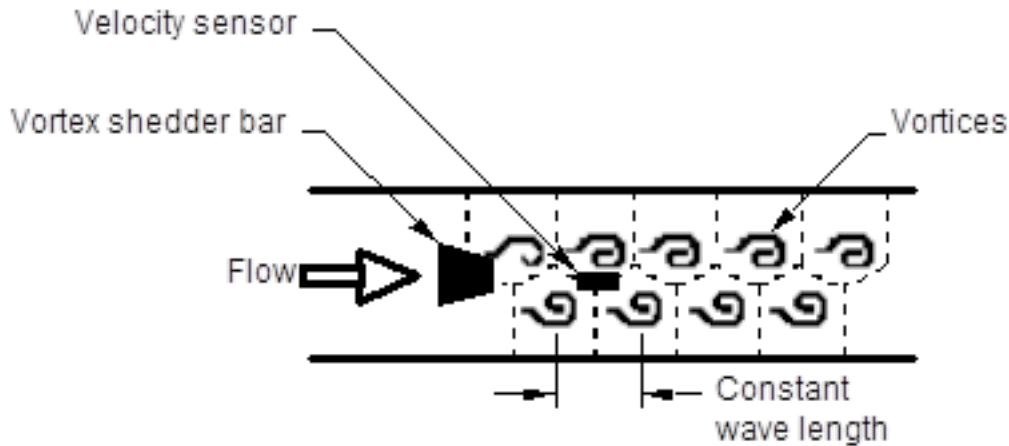

Figure 2. Measurement Principle of Vortex Flow Meters

1.2.3 Vortex Frequency Sensing

The velocity sensor incorporates a piezoelectric element that senses the vortex frequency. This element detects the alternating lift forces produced by the Von Karman vortices flowing downstream of the vortex shedder bar. The alternating electric charge generated by the piezoelectric elements is processed by the transmitter's electronic circuit to obtain the vortex shedding frequency. The piezoelectric element is highly sensitive and operates over a wide range of flows, pressures and temperatures.

1.2.4 Flow Velocity Range

To ensure trouble-free operation, vortex flow meters must be correctly sized so that the flow velocity range through the meter lies within the measurable velocity range (with acceptable pressure drop) and the linear range.

The measurable range is defined by the minimum and maximum velocity using the following table.

	Gas	Liquid	
Vmin	$\sqrt{\frac{25}{\rho}}$ ft/s	1 ft/s	
Vmax			English ρ (lb/ft ³)
0.5 in	175 ft/s	30 ft/s	
0.75 in	250 ft/s	30 ft/s	
1 in	250 ft/s	30 ft/s	
1.5 in and greater	300 ft/s	30 ft/s	
Vmin	$\sqrt{\frac{37}{\rho}}$ ft/s	0.3 m/s	
Vmax			Metric ρ (kg/m ³)
DN15	53 m/s	9.1 m/s	
DN20	76 m/s	9.1 m/s	
DN25	76 m/s	9.1 m/s	
DN40 and greater	91 m/a	9.1 m/s	

The pressure drop for F-2700 insertion meters is negligible. The pressure drop for F-2600 in-line meters is defined as:

$$\Delta P = .00024 \rho V^2 \quad \text{English units } (\Delta P \text{ in psi, } \rho \text{ in lb/ft}^3, V \text{ in ft/sec})$$

$$\Delta P = .000011 \rho V^2 \quad \text{Metric units } (\Delta P \text{ in bar, } \rho \text{ in kg/m}^3, V \text{ in m/sec})$$

The linear range is defined by the Reynolds number. The Reynolds number is the ratio of the inertial forces to the viscous forces in a flowing fluid and is defined as:

Where

- Re = Reynolds Number
- ρ = mass density of the fluid being measured
- V = velocity of the fluid being measured
- D = internal diameter of the flow channel
- μ = viscosity of the fluid being measured

$$Re = \frac{\rho V D}{\mu}$$

The Strouhal number is the other dimensionless number that quantifies the vortex phenomenon. The Strouhal number is defined as:

Where

- St = Strouhal Number
- f = frequency of vortex shedding
- d = shedder bar width
- V = fluid velocity

$$St = \frac{f d}{V}$$

As shown in Figure 3, F-2600 & F-2700 meters exhibit a constant Strouhal number across a large range of Reynolds numbers, indicating a consistent linear output over a wide range of flows and fluid types. Below this linear range, the intelligent electronics in the meter automatically corrects for the variation in the Strouhal number with the Reynolds number. The meter's smart electronics corrects for this non-linearity via its simultaneous measurements of the process fluid temperature and pressure. This data is then used to calculate the Reynolds number in real time. The meter automatically corrects down to a Reynolds number of 5,000.

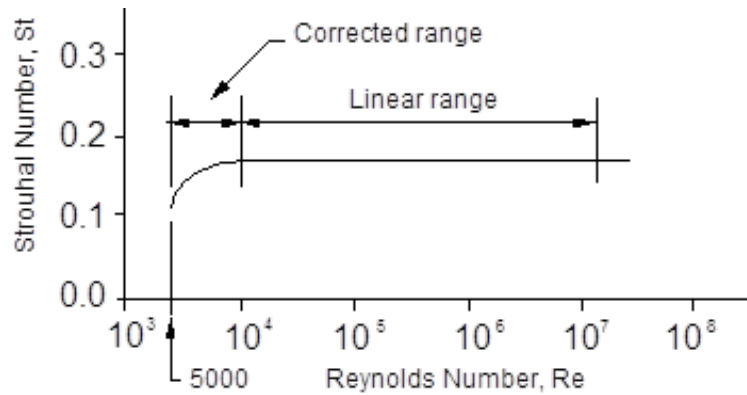

Figure 3. Reynolds Number Range for the meter

1.2.5 Temperature Measurement

This flow meter uses a 1000 ohm platinum resistance temperature detector (PRTD) to measure fluid temperature.

1.2.6 Pressure Measurement

Both versions of the meter incorporate a solid-state pressure transducer isolated by a 316 SS diaphragm. The transducer itself is micro-machined silicon, fabricated using integrated circuit processing technology. A nine-point pressure/temperature calibration is performed on every sensor. Digital compensation allows these transducers to operate within a 0.3% of full scale accuracy band within the entire ambient temperature range of -40° F to 140° F (-40° C to 60° C). Thermal isolation of the pressure transducer ensures the same accuracy across the allowable process fluid temperature range of -330° F to 750° F (-200° C to 400° C).

1.3 Flow Meter Configurations

Our vortex mass flow meters are available in two model configurations:
In-line F-2600 Series Flow Meters (replaces a section of the pipeline)
Insertion F-2700 Series Flow Meters (requires a tap into an existing pipeline)

Both the in-line and insertion configurations are similar in that they both use identical electronics and have similar sensor heads. Besides installation differences, the main difference between an in-line flow meter and an insertion flow meter is their method of measurement.

For an in-line vortex flow meter, the shedder bar is located across the entire diameter of the flow body. Thus, the entire pipeline flow is included in the vortex formation and measurement. The sensing head, which directly measures velocity, temperature and pressure, is located just downstream of the shedder bar.

Insertion vortex flow meters have a shedder bar located across the diameter of a short tube. The velocity, temperature and pressure sensor is located within this tube just downstream of a built-in shedder bar. This entire assembly is called the insertion sensing head. It fits through any entry port with a 1.875 inch minimum internal diameter.

The sensing head of an insertion vortex flow meter directly monitors the velocity at a point in the cross-sectional area of a pipe, duct, or stack (referred to as “channels”). The velocity at a point in the pipe varies as a function of the Reynolds number. The insertion vortex flow meter computes the Reynolds number and then computes the total flow rate in the channel. The output signal of insertion meters is the total flow rate in the channel. The accuracy of the total flow rate computation depends on adherence to the piping installation requirements given in Section 2. If adherence to those guidelines cannot be met, contact ONICON for specific installation advice.

1.3.1 Multivariable Options

The both versions of the meter are capable of providing the following flow measurement options:

Volumetric flow; Mass flow with temperature compensation; Mass flow with temperature and pressure compensation; Steam energy flow with temperature compensation; Steam energy flow with temperature and pressure compensation, Mass or Energy flow with temperature and external pressure compensation and Net Energy using a second temperature sensor.

1.3.2 Line Size / Process Connections / Materials

The in-line model is built for line sizes ½" through 4" wafer or ½" through 12" flanged design using ANSI 150, 300, 600, PN16, 40, or 63 class flanges.

The insertion model can be used in line sizes 2" and greater and is built with a packing gland design using 2" NPT, or 2" flanged connections (ANSI 150, 300, 600, PN16, 40, or 63 class flanges). The packing gland design can be ordered with a permanent or removable retractor.

The standard in-line model is built with 316L stainless steel, A105 carbon steel and Hastelloy C-276 versions are available via special order. The insertion model is built with 316L stainless steel.

1.3.3 Flow Meter Electronics

The flow meter electronics are available mounted directly to the flow body, or mounted remotely. The electronics housing may be used indoors or outdoors, including wet environments. Available input power options are: DC loop powered (2-wire), DC powered, or AC powered. Three analog output signals are available for your choice of three of the five process variables: mass flow rate, volumetric flow rate, temperature, pressure or fluid density. A pulse output signal for remote totalization and BACnet, MODBUS or HART communications is also available.

Each meter includes a local 2 x 16 character LCD display housed within the enclosure. Local operation and reconfiguration is accomplished using six push buttons operated via finger touch. For hazardous locations, the six buttons can be operated with the electronics enclosure sealed using a hand-held magnet, thereby not compromising the integrity of the hazardous location certification.

The electronics include nonvolatile memory that stores all configuration information. The nonvolatile memory allows the flow meter to function immediately upon power up or after an interruption in power. All flow meters are calibrated and configured for the customer's flow application.

SECTION 2.0 INSTALLATION

2.1 INSTALLATION OVERVIEW

ONICON F-2600 & F-2700 Vortex Flow Meter installations are simple and straightforward. Both the inline and the insertion type flow meter installations are covered in this chapter. After reviewing the installation requirements given below, see page 21 for inline installation instructions. See page 24 for insertion style installation instructions. Wiring instructions begin on page 38.

2.1.1 Flow Meter Installation Requirements



WARNING

Consult the flow meter nameplate for specific flow meter approvals before any hazardous location installation.

Before installing the flow meter, verify the installation site allows for these considerations:

1. Line pressure and temperature will not exceed the flow meter rating.
2. The location meets the required minimum number of pipe diameters upstream and downstream of the sensor head as illustrated in Figure 4.
3. Safe and convenient access with adequate overhead clearance for maintenance purposes.
4. Verify that the cable entry into the instrument meets the specific standard required for hazardous area installations.
5. For remote installations, verify the supplied cable length is sufficient to connect the flow meter sensor to the remote electronics.

Also, before installation, check your flow system for anomalies such as:

- Leaks
- Valves or restrictions in the flow path that could create disturbances in the flow profile that might cause unexpected flow rate indications

2.1.2 Recommended Meter Locations

Liquid Horizontal

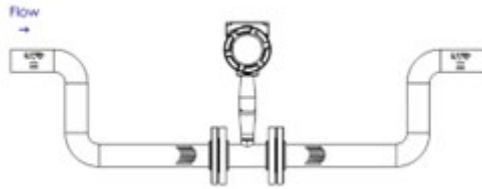

Liquid Vertical

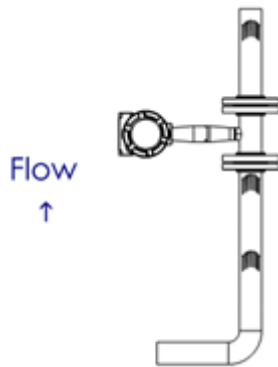

Gas or Steam Horizontal

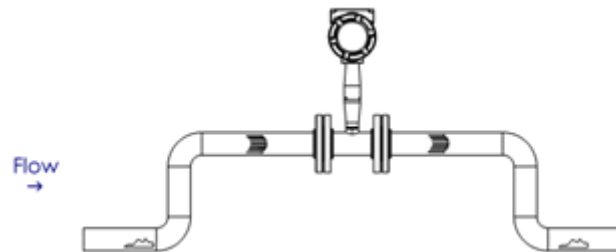

Gas or Steam Vertical

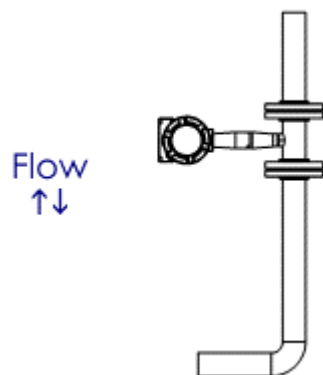

2.1.3 Unobstructed Flow Requirements

Select an installation site that will minimize possible distortion in the flow profile. Valves, elbows, control valves and other piping components may cause flow disturbances. Check your specific piping condition against the examples shown below. In order to achieve accurate and repeatable performance, install the flow meter using the recommended number of straight run pipe diameters upstream and downstream of the sensor.

Note: For liquid applications in vertical pipes, avoid installing with flow in the downward direction because the pipe may not be full at all points. Choose to install the meter with flow in the upward direction, if possible.

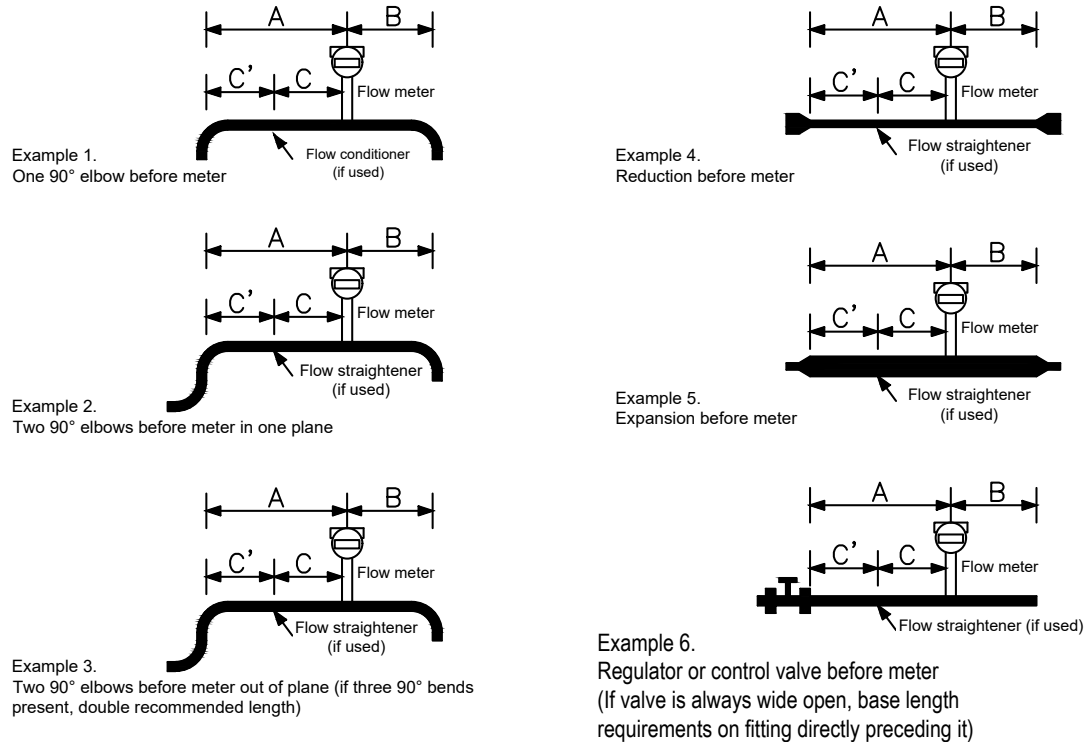

	Minimum Required Upstream Diameters				Minimum Required Downstream Diameters	
	No Flow Straightener	With Flow Straightener			No Flow Straightener	With Flow Straightener
Example	A	A	C	C'	B	B
1	10 D	N/A	N/A	N/A	5 D	5 D
2	15 D	10 D	5 D	5 D	5 D	5 D
3	30 D	10 D	5 D	5 D	10 D	5 D
4	10 D	10 D	5 D	5 D	5 D	5 D
5	20 D	10 D	5 D	5 D	5 D	5 D
6	30 D	10 D	5 D	5 D	10 D	5 D

D = Internal diameter of channel.

Figure 4. Recommended Pipe Length Requirements for Installation

2.2 F-2600 SERIES IN-LINE FLOW METER INSTALLATION

Install the in-line flow meter between two conventional pipe flanges as shown in Figures 6 and 7. Table 1 provides the recommended minimum stud bolt lengths for wafer-style meter body size and different flange ratings.

The meter's inside diameter is equal to the same size nominal pipe ID in schedule 80. For example, a 2" meter has an ID of 1.939" (2" schedule 80). **Do not install the meter in a pipe with an inside diameter smaller than the inside diameter of the meter.** For schedule 160 and higher pipe, a special meter is required. Consult the factory before purchasing the meter.

In-line meters require customer-supplied gaskets. When selecting gasket material, make sure that it is compatible with the process fluid and pressure ratings of the specific installation. Verify that the inside diameter of the gasket is larger than the inside diameter of the flow meter and adjacent piping. If the gasket material extends into the flow stream, it will disturb the flow and cause inaccurate measurements.

Flange Bolt Specifications

Stud Bolt Lengths for Each Flange Rating (inches)			
Line Size	Class 150 and PN16	Class 300 and PN40	Class 600 and PN64
1 "	6.00	7.00	7.50
1½ "	6.25	8.50	9.00
2 "	8.50	8.75	9.50
3 "	9.00	10.00	10.50
4 "	9.50	10.75	12.25

Table 1. Minimum Recommended Stud Bolt Lengths for Wafer Meters

The required bolt load for sealing the gasket joint is affected by several application-dependent factors; therefore, the required torque for each application may be different. Refer to the ASME Pressure Vessel Code guidelines for bolt tightening standards.

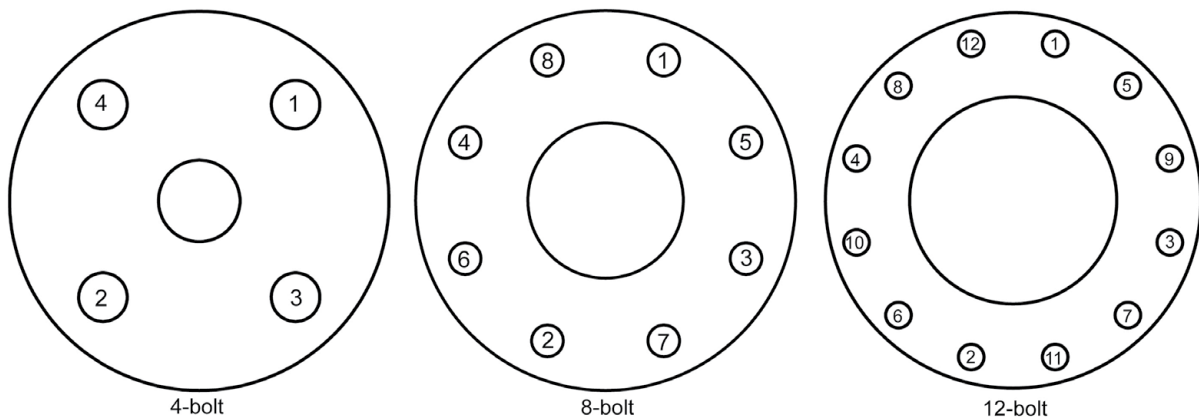

Figure 5. Flange Bolt Tightening Sequence

2.2.1 Wafer-Style Flow Meter Installation

Install the wafer-style meter between two conventional pipe flanges of the same nominal size as the flow meter. If the process fluid is a liquid, make sure the meter is located where the pipe is always full. This may require locating the meter at a low point in the piping system. Note: Vortex flow meters are not suitable for two-phase flows (i.e., liquid and gas mixtures). For horizontal pipelines having a process temperature above 300° F, mount the meter at a 45o or 90o angle to avoid overheating the electronics enclosure. To adjust the viewing angle of the enclosure or display/keypad, see page 34 and 35.

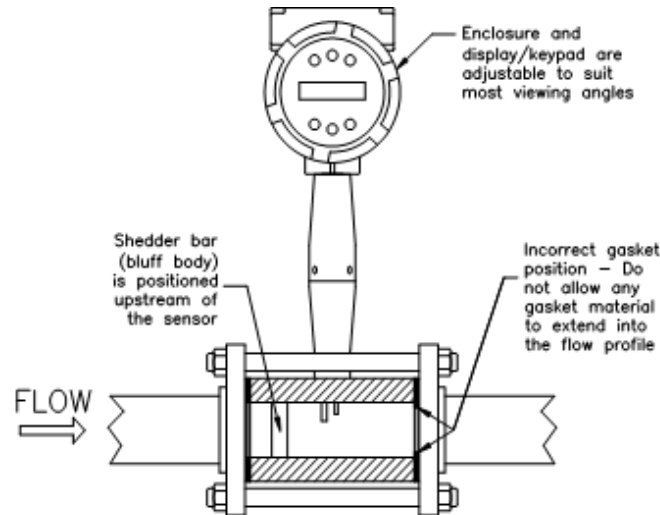

Figure 6. Wafer-Style Flow Meter Installation



CAUTION

When using toxic or corrosive gases, purge the line with inert gas for a minimum of four hours at full gas flow before installing the flow meter.

When installing the meter make sure the section marked with a flow arrow is positioned upstream of the outlet, with the arrow head pointing in the direction of flow. (The mark is on the wafer adjacent to the enclosure mounting neck.) This ensures that the sensor head is positioned downstream of the vortex shedder bar and is correctly aligned to the flow. Installing the meter opposite this direction will result in completely inaccurate flow measurement. To install the meter:

1. Confirm that the installation site meets the required minimum upstream and downstream pipe diameters. Turn off the flow of process gas, liquid or steam. Verify that the line is not pressurized.
2. Insert the studs for the bottom side of the meter body between the pipe flanges. Place the wafer-style meter body between the flanges with the end stamped with a flow arrow on the upstream side, with the arrow head pointing in the direction of flow. Center the meter body inside the diameter with respect to the inside diameter of the adjoining piping.
3. Position the gasket material between the mating surfaces. Make sure both gaskets are smooth and even with no gasket material extending into the flow profile. Obstructions in the pipeline will disturb the flow and cause inaccurate measurements.
4. Place the remaining studs between the pipe flanges. Tighten the nuts in the sequence shown in Figure 5. Check for leaks after tightening the flange bolts.

2.2.2 Flange-Style Flow Meter Installation

Install the flange-style meter between two conventional pipe flanges of the same nominal size as the flow meter. If the process fluid is a liquid, make sure the meter is located where the pipe is always full. This may require locating the meter at a low point in the piping system. Note: Vortex flow meters are not suitable for two-phase flows (i.e., liquid and gas mixtures). For horizontal pipelines having a process temperature above 300° F, mount the meter at a 45° or 90° angle to avoid overheating the electronics enclosure. To adjust the viewing angle of the enclosure or display/keypad, see page 34 and 35.

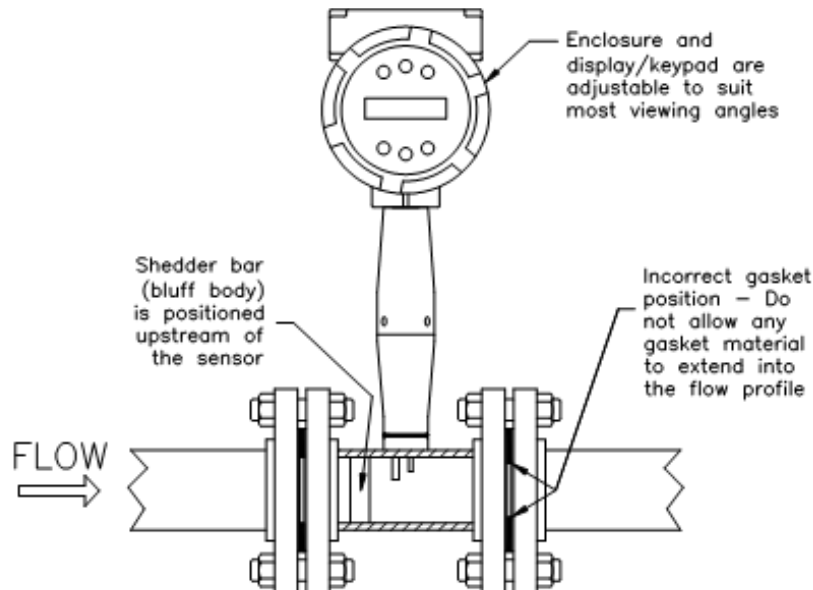

Figure 7. Flange-Style Flow Meter Installation



CAUTION

When using toxic or corrosive gases, purge the line with inert gas for a minimum of four hours at full gas flow before installing the flow meter.

When installing the meter make sure the flange marked with a flow arrow is positioned upstream of the outlet flange, with the arrow head pointing in the direction of flow. (The mark is on the flange adjacent to the enclosure mounting neck.) This ensures that the sensor head is positioned downstream of the vortex shedder bar and is correctly aligned to the flow. Installing the meter opposite this direction will result in completely inaccurate flow measurement. To install the meter:

1. Confirm that the installation site meets the required minimum upstream and downstream pipe diameters. Turn off the flow of process gas, liquid or steam. Verify that the line is not pressurized.
2. Seat the meter level and square on the mating connections with the flange stamped with a flow arrow on the upstream side, with the arrow head pointing in the direction of flow. Position a gasket in place for each side. Make sure both gaskets are smooth and even with no gasket material extending into the flow profile. Obstructions in the pipeline will disturb the flow and cause inaccurate measurements.
3. Install bolts in both process connections. Tighten the nuts in the sequence shown in Figure 5. Check for leaks after tightening the flange bolts.

2.3 F-2700 SERIES INSERTION FLOW METER INSTALLATION

Prepare the pipeline for installation using either a standard or hot tap method described on the following pages. Refer to a standard code for all pipe tapping operations. The following tapping instructions are general in nature and intended for guideline purposes only. Before installing the meter, review the mounting position and isolation value requirements given below.

Mounting Position

Allow clearance between the electronics enclosure top and any other obstruction when the meter is fully retracted.

Isolation Valve Selection

Always install an isolation valve with insertion style meters. If you supply the isolation valve, it must meet the following requirements:

1. A minimum valve bore diameter of 1.875" is required, and the valve's body size should be 2". Normally, gate valves are used.
2. Verify that the valve's body and flange rating are within the flow meter's maximum operating pressure and temperature.
3. Choose an isolation valve with at least two inches existing between the flange face and the gate portion of the valve. This ensures that the flow meter's sensor head will not interfere with the operation of the isolation valve.

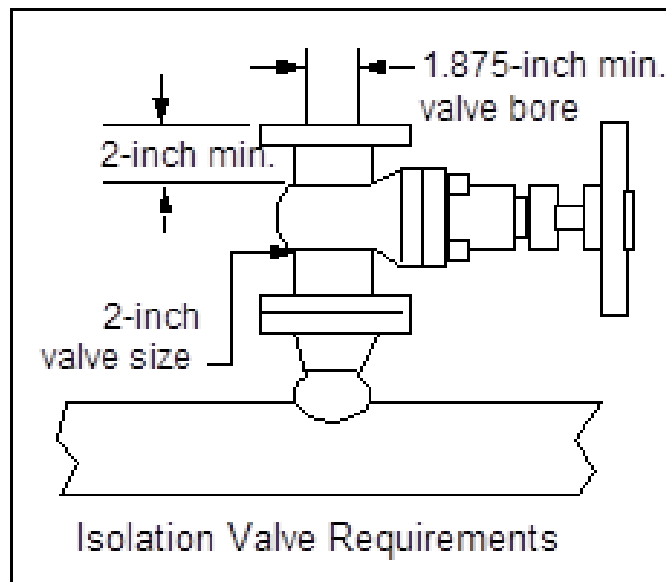

Figure 8. Isolation Valve Requirements

2.3.1 Standard Installation Guidelines



CAUTION

When using toxic or corrosive gases, purge the line with inert gas for a minimum of four hours at full gas flow before installing the flow meter.

Refer to a standard code for all pipe tapping operations. The following tapping instructions are general in nature and intended as a guideline only.

1. Confirm that the installation site meets the minimum upstream and downstream pipe diameter requirements. See Figure 4.
2. Turn off the flow of process gas, liquid or steam. Verify that the line is not pressurized.
3. Use a cutting torch or sharp cutting tool to tap into the pipe. The pipe opening must be at least 1.875" in diameter. (Do not attempt to insert the sensor probe through a smaller hole.)
4. Remove all burrs from the hole. Rough edges may cause flow profile distortions that could affect flow meter accuracy. Also, obstructions could damage the sensor assembly when inserting into the pipe.



WARNING

All flow meter connections, isolation valves and fittings for cold tapping must have the same or higher pressure rating as the main pipeline.

5. After cutting, measure the thickness of the cut-out and record this number for calculating the insertion depth.
6. Weld the flow meter pipe connection onto the pipe. Make sure this connection is within $\pm 5^\circ$ perpendicular to the pipe center line.
7. Install the isolation valve.
8. When welding is complete and all fittings are installed, close the isolation valve or cap the line. Run a static pressure check on the welds. If pressure loss or leaks are detected, repair the joint and re-test.
9. Connect the meter to the pipe process connection.
10. Calculate the sensor probe insertion depth and insert the sensor probe into the pipe as described on the following pages.

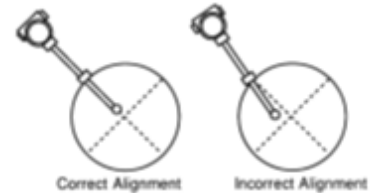

2.3.2 Hot Tap Guidelines



WARNING

Hot tapping must be performed by a trained professional. US regulations often require a hot tap permit. The manufacturer of the hot tap equipment and/or the contractor performing the hot tap is responsible for providing proof of such a permit.

Refer to a standard code for all pipe tapping operations. The following tapping instructions are general in nature and intended as a guideline only.

1. Confirm that the installation site meets the minimum upstream and downstream pipe diameter requirements.
2. Weld a 2" mounting adapter on the pipe. Make sure the mounting adapter is within $\pm 5^\circ$ perpendicular to the pipe center line (see previous page). The pipe opening must be at least 1.875" in diameter.
3. Connect a 2" process connection on the mounting adapter.
4. Connect an isolation valve on the process connection. The valve's full open bore must be at least 1.875" in diameter.
5. Run a static pressure check on the welds. If pressure loss or leaks are detected, repair the joint and re-test.
6. Connect the hot tapping equipment to the isolation valve, open the isolation valve and drill at least a 1.875" diameter hole.
7. Retract the drill, close the isolation valve, and remove the hot tapping equipment.
8. Connect the flow meter to the isolation valve and open the isolation valve.
9. Calculate the sensor probe insertion depth and insert the sensor probe into the pipe as described on the following pages.



WARNING

All flow meter connections, isolation valves, and fittings for hot tapping must have the same or higher pressure rating as the main pipeline.

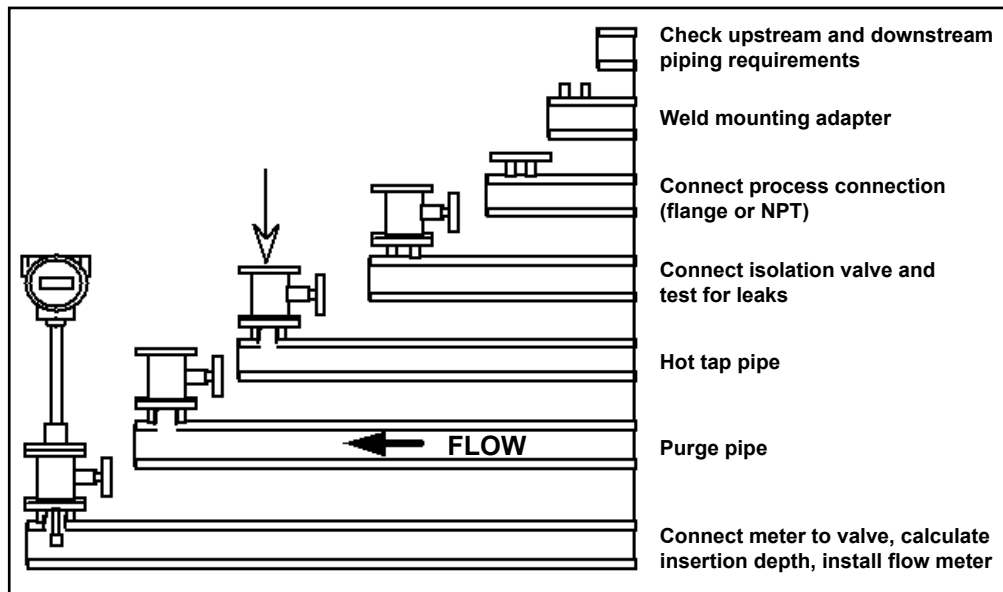

Figure 9. Hot Tap Sequence

2.4 FLOW METER INSERTION

The sensor head must be properly positioned in the pipe. For this reason, it is important that insertion length calculations are carefully followed. A sensor probe inserted at the wrong depth in the pipe will result in inaccurate readings.

Insertion flow meters are applicable to pipes 3" and larger. For pipe sizes 10" and smaller, the center line of the meter's sensing head is located at the pipe's center line. For pipe sizes larger than 10", the center line of the sensing head is located in the pipe's cross section 5" from the inner wall of the pipe; i.e., its "wetted" depth from the wall to the center line of the sensing head is 5".

Insertion flow meters are available in two probe lengths:

Standard Probe configuration is used with most flow meter process connections. The length, S, of the stem is 29.47".

12 Inch Extended Probe configuration is used with exceptionally lengthy flow meter process connections. The length, S, of the stem is 41.47".

Use the Correct Insertion Formula

Depending on your flow meter's process connection, use the applicable insertion length formula and installation procedure as follows:

- Flow meters with a packing gland type connection (NPT or flanged) configured with an insertion tool, follow the instructions beginning on page 29.
- Flow meters with a packing gland type connection (NPT or flanged) without an insertion tool, follow the instructions beginning on page 32.



WARNING

An insertion tool must be used for any installation where a flow meter is inserted under pressure greater than 50 psig.

2.4.1 Installing Flow Meters with a Packing Gland Connection*

Use the formula below to determine the insertion depth for flow meters (NPT and flanged) equipped with an insertion tool. To install, see the next page for instructions for meters with a permanent insertion tool. For meters with a removable insertion tool, see page 33.

	Insertion Length Formula $I = F + R + t - 1.35$
	<p>Where:</p> <p>I = Insertion length.</p> <p>F = Distance from the raised face of the flange or top of the process connection for NPT style meters to the top outside of the process pipe.</p> <p>R = Pipe inside diameter divided by 2 for pipes ten" & smaller.</p> <p>R = Five" for pipe diameters larger than ten".</p> <p>t = Thickness of the pipe wall. (Measure the disk cutout from the tapping procedure or check a piping handbook for thickness.)</p>

Figure 10. Insertion Calculation (Meters with Insertion Tool)

Example 1: Flange Style Meters:

To install an insertion style flow meter into a 14" schedule 40 pipe, the following measurements are taken:

$$\begin{aligned} F &= 12" \\ R &= 5" \\ t &= 0.438" \end{aligned}$$

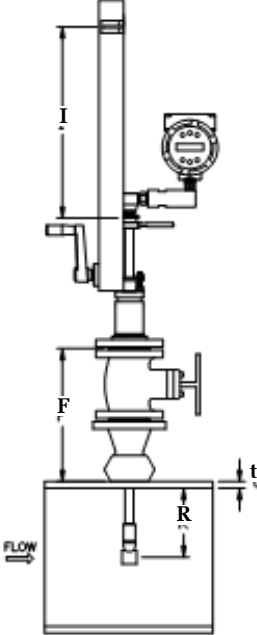
The example insertion length is 16.09".

Example 2: NPT Style Meters:

The length of thread engagement on the NPT style meters is also subtracted in the equation. The length of the threaded portion of the NPT meter is 1.18". Measure the thread portion still showing after the installation and subtract that amount from 1.18". This gives you the thread engagement length. If this cannot be measured use .55" for this amount.

$$\begin{aligned} F &= 12" \\ R &= 5" \\ t &= 0.438" \end{aligned}$$

The example insertion length is 15.54".

**All dimensions are in inches.*

2.4.2 Insertion Procedure for Flow Meters with Permanent Insertion Tool

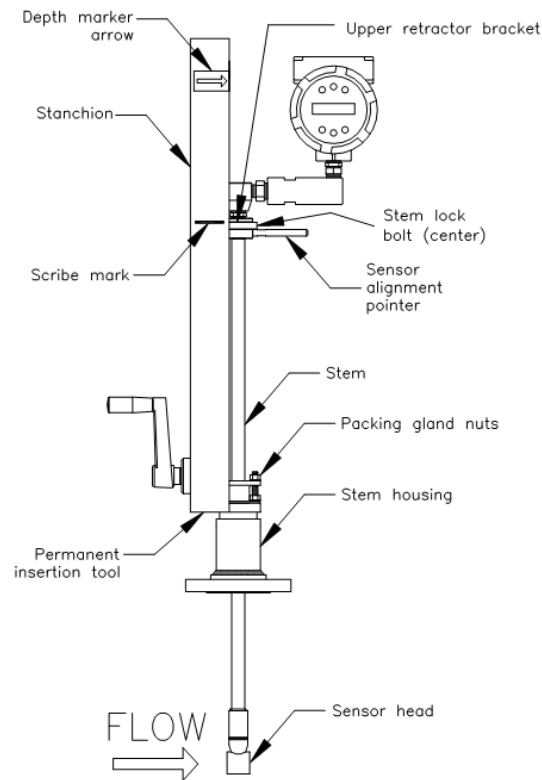

Figure 11. Flow Meter with Permanent Insertion Tool

1. Calculate the required sensor probe insertion length (see previous page). Measure from the depth marker arrow down the stanchion and scribe a mark at the calculated insertion depth.
2. Fully retract the flow meter until the sensor head is touching the bottom of the stem housing. Attach the meter assembly to the 2" full-port isolation valve, if used. Use Teflon tape or pipe sealant to improve seal and prevent seizing on NPT style.
3. Loosen the two packing gland nuts on the stem housing of the meter. Loosen the stem lock bolt adjacent to the sensor alignment pointer. Align the sensor head using the sensor alignment pointer. Adjust the alignment pointer parallel to the pipe and pointing downstream. Tighten the stem lock bolt to secure the sensor position.
4. Slowly open the isolation valve to the full open position. If necessary, slightly tighten the two packing gland nuts to reduce the leakage around the stem.
5. Turn the insertion tool handle clockwise to insert the sensor head into the pipe. Continue until the top of the upper retractor bracket aligns with the insertion length position scribed on the stanchion. Do not force the stem into the pipe.
6. Tighten the packing gland nuts to stop leakage around the stem. Do not torque over 20 ft-lb.



CAUTION

The sensor alignment pointer must point downstream, in the direction of flow.



IMPORTANT NOTE

If line pressure is above 500 psig, it could require up to 25 ft lb of torque to insert the flow meter. Do not confuse this with possible interference in the pipe.

2.4.3 Insertion Procedure for Flow Meters with Removable Insertion Tool

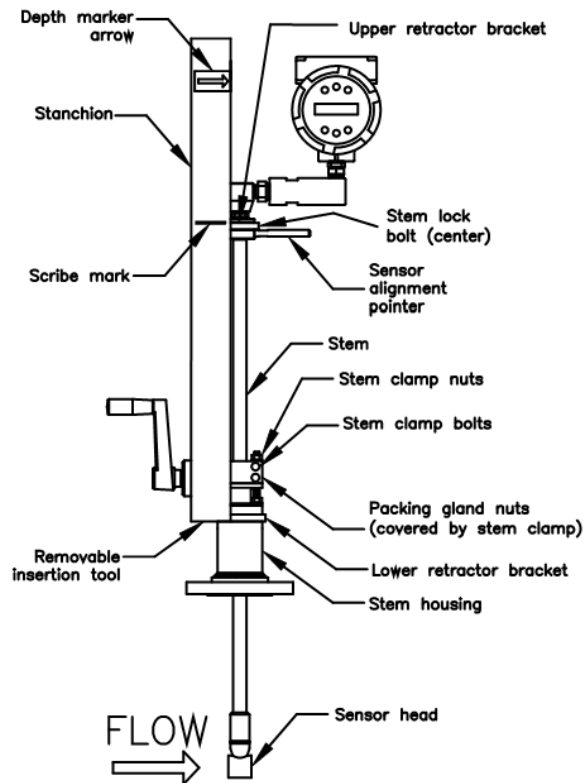

Figure 12. Flow Meter with Removable Insertion Tool

1. Calculate the required sensor probe insertion length. Measure from the depth marker arrow down the stanchion and scribe a mark at the calculated insertion depth.
2. Fully retract the flow meter until the sensor head is touching the bottom of the stem housing. Attach the meter assembly to the 2" full-port isolation valve, if used. Use Teflon tape or pipe sealant to improve seal and prevent seizing on NPT style.
3. Remove the two top stem clamp nuts and loosen two stem clamp bolts. Slide the stem clamp away to expose the packing gland nuts.
4. Loosen the two packing gland nuts. Loosen the stem lock bolt adjacent to the sensor alignment pointer. Align the sensor head using the sensor alignment pointer. Adjust the alignment pointer parallel to the pipe and pointing downstream. Tighten the stem lock bolt to secure the sensor position.
5. Slowly open the isolation valve to the full open position. If necessary, slightly tighten the two packing gland nuts to reduce the leakage around the stem.
6. Turn the insertion tool handle clockwise to insert the stem into the pipe. Continue until the top of the upper retractor bracket lines up with the insertion length mark scribed on the stanchion. Do not force the stem into the pipe.



CAUTION

The sensor alignment pointer must point downstream in the direction of flow.



IMPORTANT NOTE

If line pressure is above 500 psig, it could require up to 25 ft lb of torque to insert the flow meter. Do not confuse this with possible interference in the pipe.

7. Tighten the packing gland nuts to stop leakage around the stem. Do not torque over 20 ft-lbs.
8. Slide the stem clamp back into position. Torque stem clamp bolts to 15 ft-lbs. Replace the stem clamp nuts and torque to 10-15 ft-lbs.
9. To separate the insertion tool from the flow meter, remove four socket head cap bolts securing the upper and lower retractor brackets. Remove the insertion tool.

2.4.4 Installation of Meters with Packing Gland Connection (No Insertion Tool)*

Use the following formula to determine insertion depth for meters with a packing gland connection (NPT and flanged) without an insertion tool.

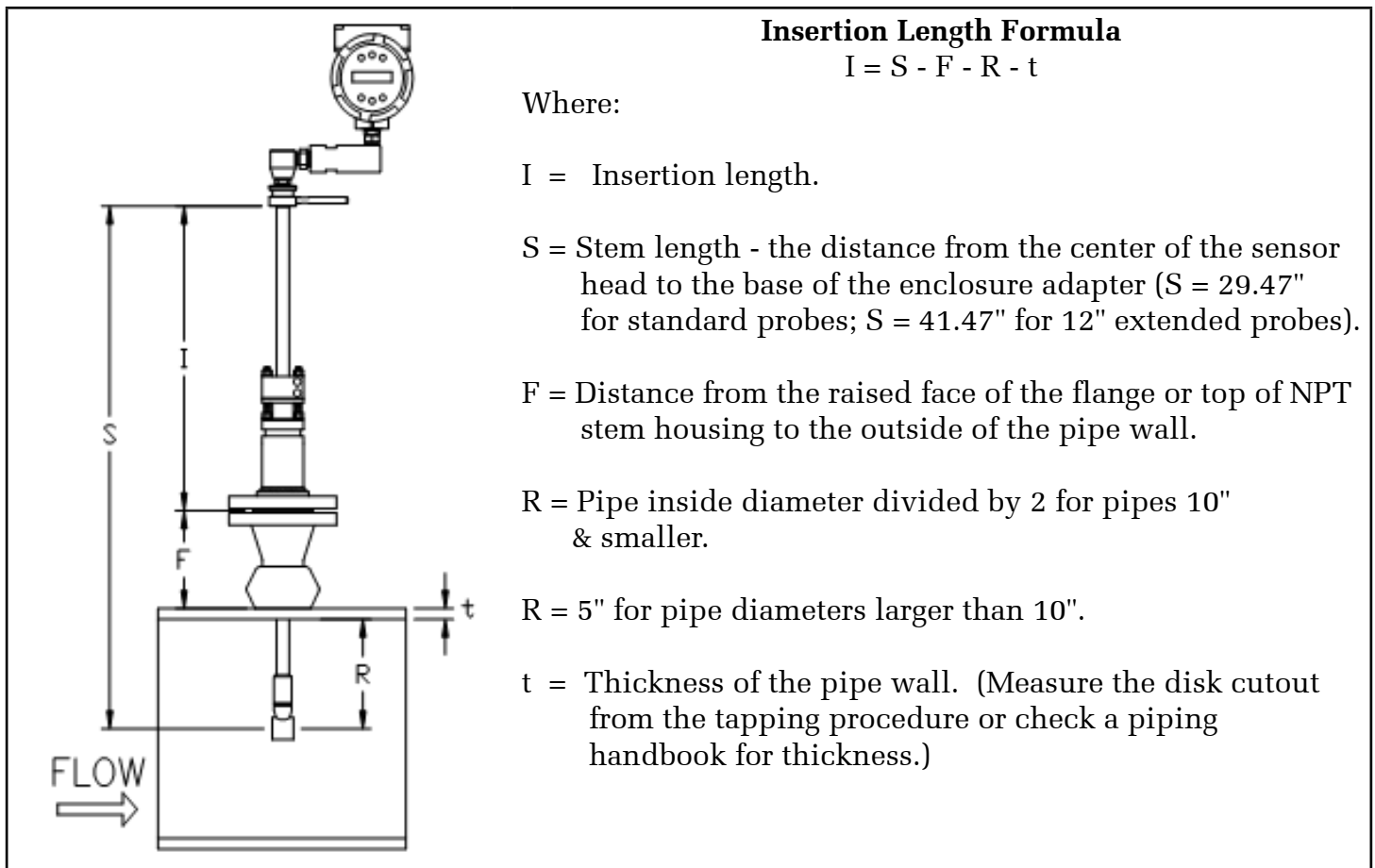

Figure 13. Insertion Calculation (Meters without Insertion Tool)

Example:

To install an insertion style flow meter with a standard probe (S = 29.47) into a 14" schedule 40 pipe, the following measurements are taken:

F = 3"
 R = 5"
 t = 0.438"

The example insertion length is 21.03".

**All dimensions are in inches.*

2.4.5 Insertion Procedure for Flow Meters with No Insertion Tool (Packing Gland Connection)

1. Calculate the required sensor probe insertion length.
2. Fully retract the stem until the sensor head is touching the bottom of the stem housing. Remove the two top stem clamp nuts and loosen two stem clamp bolts. Slide the stem clamp away to expose the packing gland nuts. Loosen the two packing gland nuts.
3. Align the sensor head using the sensor alignment pointer. Adjust the alignment pointer parallel to the pipe and pointing downstream.
4. Insert the sensor head into the pipe until insertion length, I , is achieved. Do not force the stem into the pipe.
5. Tighten the packing gland nuts to stop leakage around the stem. Do not torque over 20 ft-lbs.
6. Slide the stem clamp back into position. Torque stem clamp bolts to 15 ft-lbs. Replace the stem clamp nuts and torque to 10-15 ft-lbs.



WARNING

The line pressure must be less than 50 psig for installation.



CAUTION

The sensor alignment pointer must point downstream, in the direction of flow.

2.5 ADJUSTING METER ORIENTATION

Depending on installation requirements, you may need to adjust the meter orientation. There are two adjustments available. The first rotates the position of the LCD display/keypad and is available on both in-line and insertion meters. The second is to rotate the enclosure position. This adjustment is only allowed on in-line meters.

2.5.1 Display/Keypad Adjustment (All Meters)

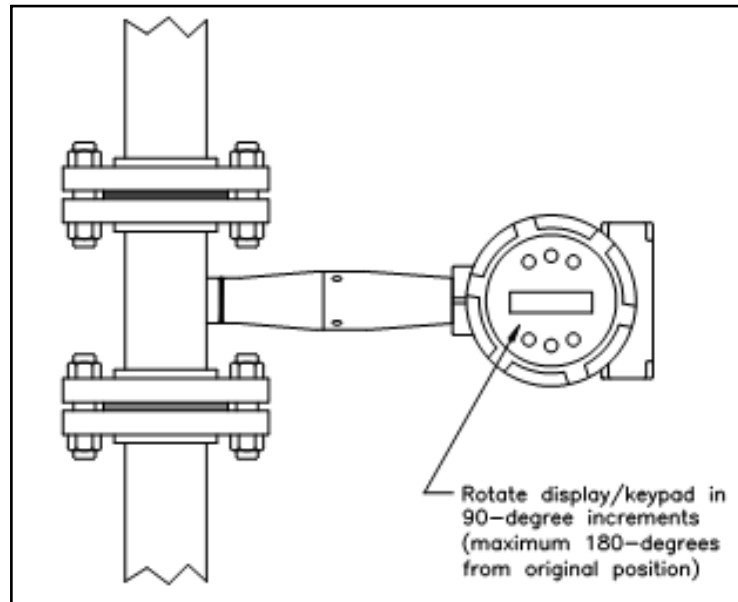

Figure 14. Display/Keypad Viewing Adjustment

The electronics boards are electrostatically sensitive. Wear a grounding wrist strap and make sure to observe proper handling precautions required for static-sensitive components. To adjust the display:

1. Disconnect power to the flow meter.
2. Loosen the small set screw which secures the electronics enclosure cover. Unscrew and remove the cover.
3. Loosen the four captive screws.
4. Carefully pull the display/microprocessor board away from the meter standoffs. Make sure not to damage the connected ribbon cable.
5. Rotate the display/microprocessor board to the desired position. Maximum turn, two positions left or two positions right (180°).
6. Align the board with the captive screws. Check that the ribbon cable is folded neatly behind the board with no twists or crimps.
7. Tighten the screws. Replace the cover and set screw. Restore power to the meter.

2.5.2 Enclosure Adjustment (In-line Only)

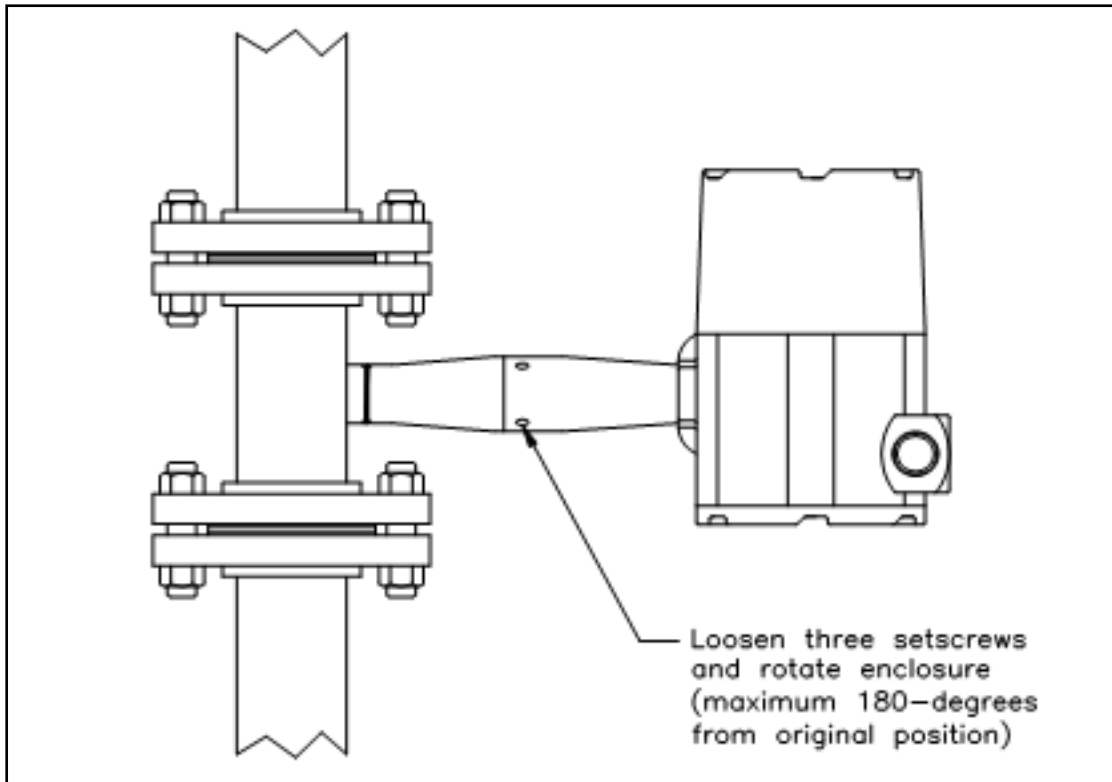

Figure 15. Enclosure Viewing Adjustment

To avoid damage to the sensor wires, do not rotate the enclosure beyond 180° from the original position. To adjust the enclosure:

1. Remove power to the flow meter.
2. Loosen the three set screws shown above. Rotate the display to the desired position (maximum 180°).
3. Tighten the three set screws. Restore power to the meter.

2.6 LOOP-POWERED FLOW METER WIRING CONNECTIONS



WARNING

To avoid potential electric shock, follow National Electric Code safety practices or your local code when wiring this unit to a power source and to peripheral devices. Failure to do so could result in injury or death. All wiring procedures must be performed with the power off.

Use a Class 2 isolated power supply that is grounded, provides DC output, and has no more than 10% output ripple



CAUTION

The DC wire insulation temperature rating must meet or exceed 85°C (185°F), maximum operating voltage 300 VRMS.

The NEMA 4X enclosure contains an integral wiring compartment with one dual strip terminal block (located in the smaller end of the enclosure). Two 3/4" female NPT conduit entries are available for separate power and signal wiring. For all hazardous area installations, only suitable certified cable glands, blanking plugs or thread adapters may be used. If conduit seals are used, they must be installed within 18" (457 mm) of the enclosure.

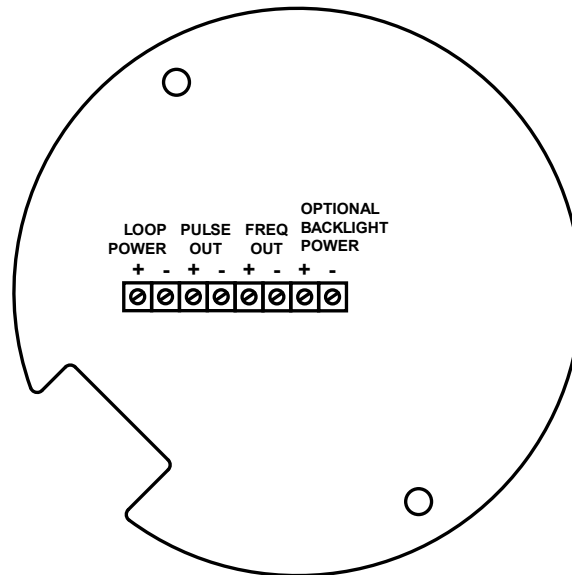

Figure 16. Wiring Terminals for Loop-Powered Version

2.6.1 Input Power Connections

To access the wiring terminal blocks, locate and loosen the small set screw which locks the small enclosure cover in place. Unscrew the cover to expose the terminal block.

DC Power Wiring

Connect 4-20 mA loop power (12 to 36 VDC at 25 mA, 1W max.) to the +Loop Power and –Loop Power terminals on the terminal block. Torque all connections to 4.43 to 5.31 in-lbs (0.5 to 0.6 Nm). The DC power wire size must be 20 to 12 AWG with the wire stripped ¼" (7 mm).

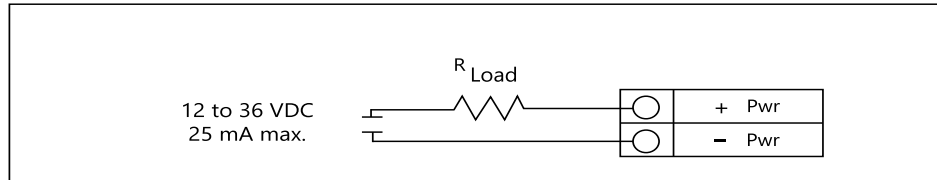

Figure 17. DC Power Connections

2.6.2 4-20 mA Output Connections

The loop powered meter has a single 4-20 mA loop. The 4-20 mA loop current is controlled by the meter electronics. The electronics must be wired in series with the sense resistor or current meter. The current control electronics requires at least 12 volts at the input terminals to operate correctly.

The maximum loop resistance (load) for the current loop output is dependent upon the supply voltage and is given in Figure 18. The 4-20 mA loop is optically isolated from the flow meter electronics.

R_{load} is the total resistance in the loop, including the wiring resistance ($R_{load} = R_{wire} + R_{sense}$). To calculate R_{max} , the maximum R_{load} for the loop, subtract the minimum terminal voltage from the supply voltage and divide by the maximum loop current, 20 mA. Thus:

$$\text{The maximum resistance } R_{load} = R_{max} = (V_{supply} - 12V) / 0.020 \text{ A}$$

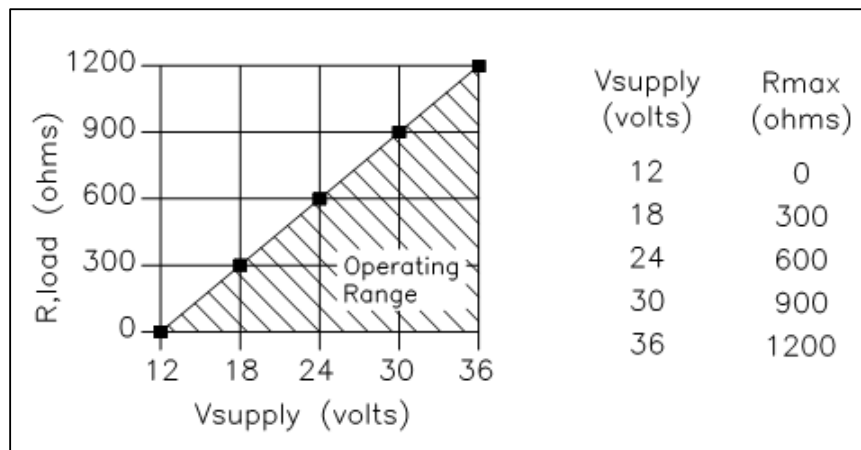

Figure 18. Load Resistance Versus Input Voltage

2.6.3 Pulse Output Connections

The pulse output is used for remote totalization. When the preset volume or mass (defined in the totalizer settings, see page 62) has passed the meter, the output provides a 50 millisecond square pulse.

The pulse output requires a separate 5 to 36 VDC power supply. The pulse output optical relay is a normally-open single-pole relay. The relay has a nominal 200 volt/160 ohm rating. This means that it has a nominal on-resistance of 160 ohms, and the largest voltage that it can withstand across the output terminals is 200 volts. However, there are current and power specifications that must be observed. The relay can conduct a current up to 40 mA and can dissipate up to 320 mW. The relay output is isolated from the meter electronics and power supply.

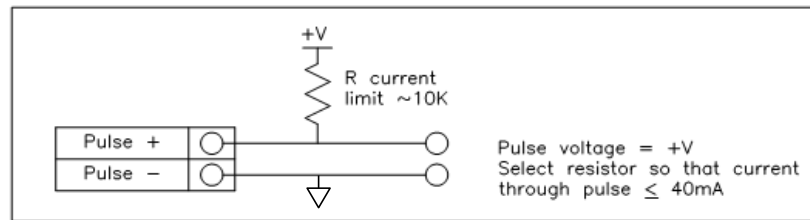

Figure 19. Isolated Pulse Output Using External Power Supply

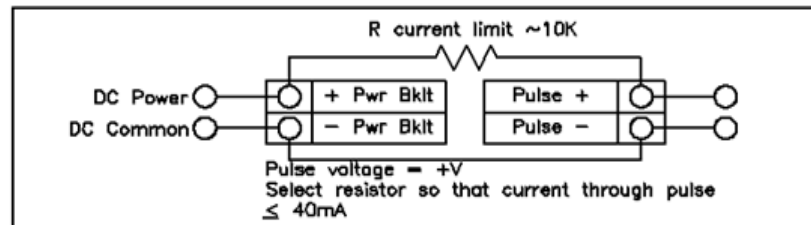

Figure 20. Non-Isolated Pulse Output Using External Power Supply

2.6.4 Frequency Output Connections

The frequency output is used for a remote counter. It can be scaled to output a 1 to 10 kHz signal proportional to mass or volume flow, temperature, pressure or density.

The frequency output requires a separate 5 to 36 VDC power supply and there are current and power specifications that must be observed when using this output. The output can conduct a current up to 40 mA and can dissipate up to 200 mW. The output is isolated from the meter electronics and power supply.

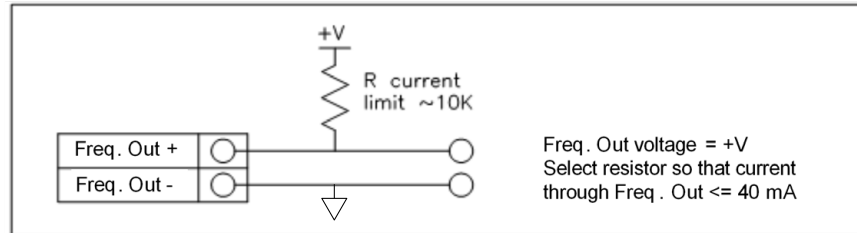

Figure 21. Isolated Frequency Output Using External Power Supply

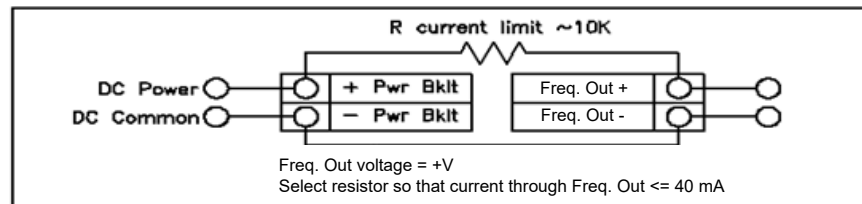

Figure 22. Non-Isolated Frequency Output Using External Power Supply

2.6.5 Optional Backlight Connection

The loop power meter has an optional backlight connection provided. It is intended to be powered by a separate 12 to 36 VDC at 35 mA max. power supply or by the pulse power input. Both options are shown below.

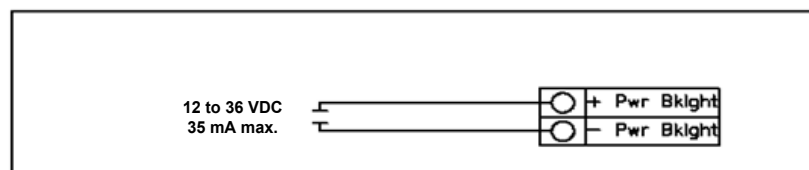

Figure 23. Backlight Using External Power Supply

2.6.6 Remote Electronics Wiring

The remote electronics enclosure should be mounted in a convenient, easy to reach location. For hazardous location installations, make sure to observe agency requirements for installation. Allow some slack in the interface cable between the junction box and the remote electronics enclosure. To prevent damage to the wiring connections, do not put stress on the terminations at any time.

The meter is shipped with temporary strain relief glands at each end of the cable. Disconnect the cable from the meter's terminal block inside the junction box - not at the remote electronics enclosure. Remove both glands and install appropriate conduit entry glands and conduit. When installation is complete, re-connect each labeled wire to the corresponding terminal position on the junction box terminal block. Make sure to connect each wire pair's shield. Note: Incorrect connection will cause the meter to malfunction.

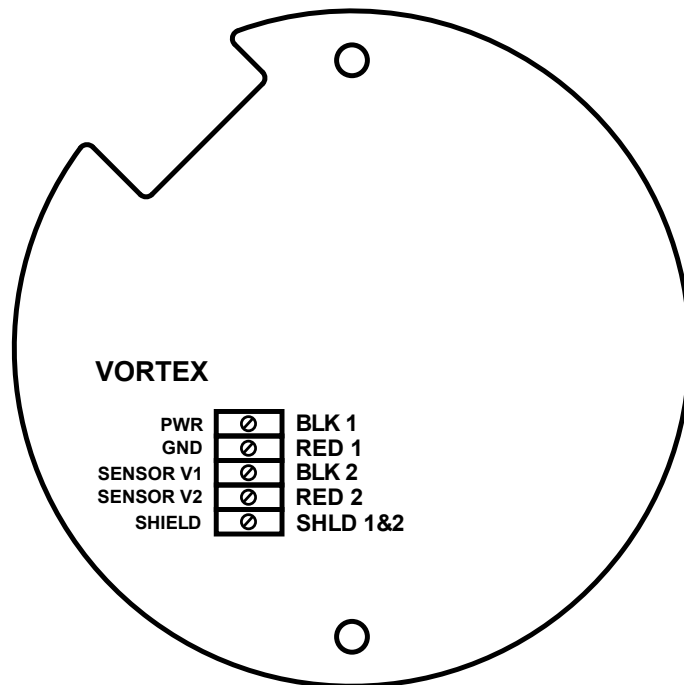

Figure 24. Loop-Powered Volumetric Flowmeter Junction Box Sensor Connections



IMPORTANT NOTE

Numeric code in junction box label matches wire labels.

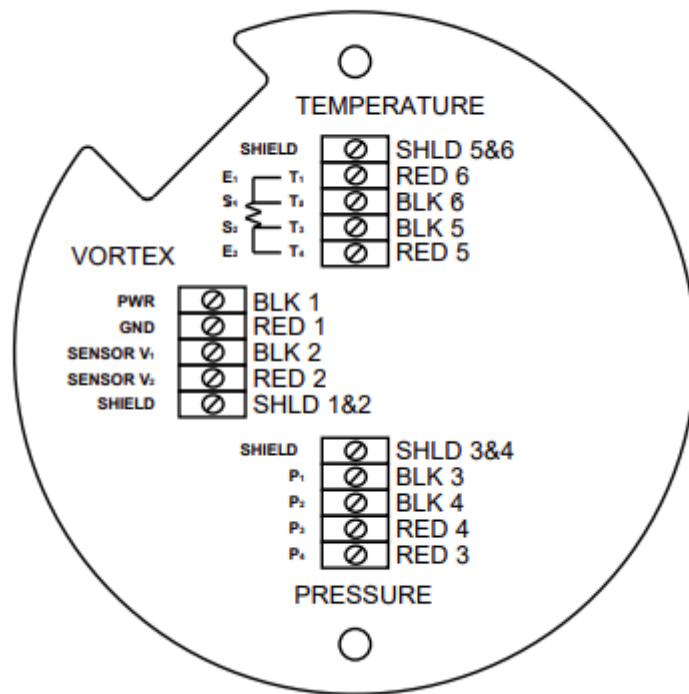

Figure 25. Loop-Power Mass Flowmeter Junction Box Sensor Connections

2.7 HIGH POWER METER WIRING CONNECTIONS



WARNING

To avoid potential electric shock, follow National Electric Code safety practices or your local code when wiring this unit to a power source and to peripheral devices. Failure to do so could result in injury or death. All AC power connections must be in accordance with published CE directives. All wiring procedures must be performed with the power off.

The NEMA 4X enclosure contains an integral wiring compartment with one dual strip terminal block (located in the smaller end of the enclosure). Two 3/4" female NPT conduit entries are available for separate power and signal wiring. For all hazardous area installations, only suitable certified cable glands, blanking plugs or thread adapters may be used. If conduit seals are used, they must be installed within 18" (457 mm) of the enclosure.

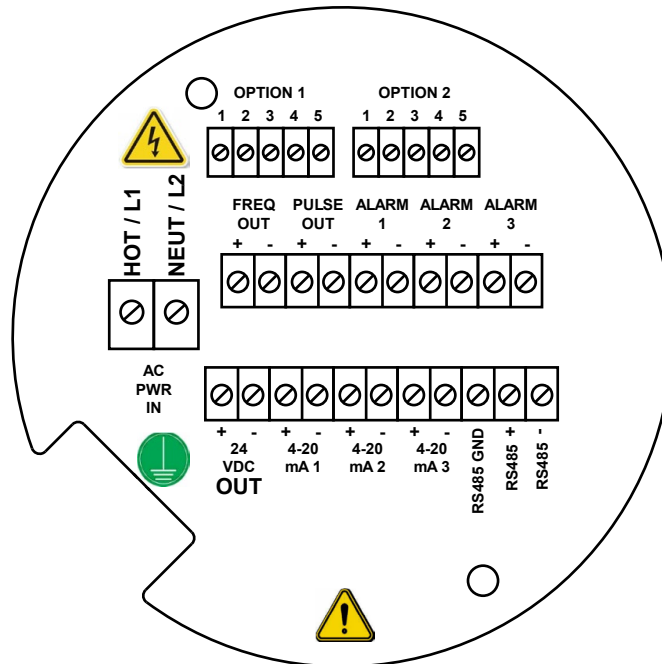

Figure 26. AC Wiring Terminals

2.7.1 Input Power Connections

To access the wiring terminal blocks, locate and loosen the small set screw which locks the small enclosure cover in place. Unscrew the cover to expose the terminal block.



CAUTION

The AC wire insulation temperature rating must meet or exceed 90°C (194°F), maximum operating voltage 600 VRMS.

The AC power wire size must be 20 to 10 AWG with the wire stripped 1/4 inch (7 mm). The wire insulation temperature must meet or exceed 185°F (85°C). Connect 100 to 240 VAC (5 W maximum) to the Hot and Neutral terminals on the terminal block. Connect the ground wire to the safety ground lug (⊕). Torque all connections to 4.43 to 5.31 in-lbs (0.5 to 0.6 Nm). Use a separate conduit entry for signal lines to reduce the possibility of AC noise interference.

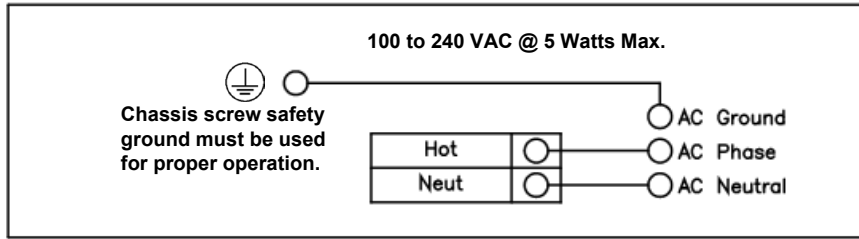

Figure 27. AC Power Connections

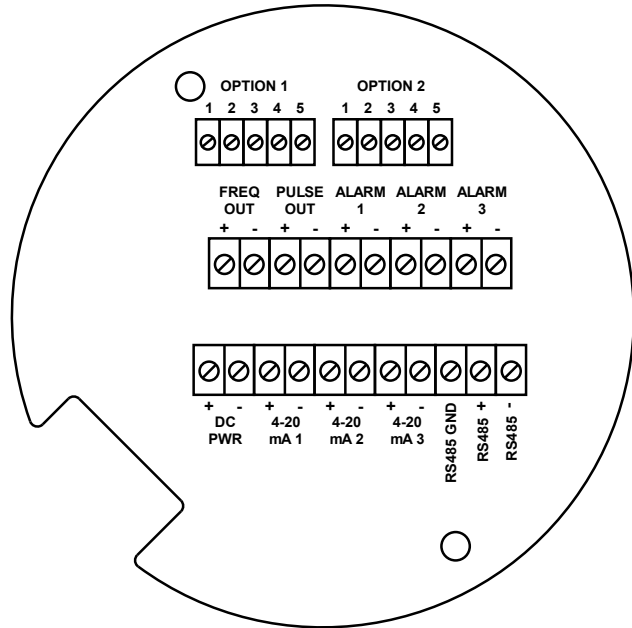

Figure 28. DC Wiring Terminals

DC Power Wiring

The DC power wire size must be 20 to 12 AWG with the wire stripped 1/4" (7 mm). Connect 18 to 36 VDC (300 mA, 9 W maximum) to the +DC Pwr and –DC Pwr terminals on the terminal block. Torque all connections to 4.43 to 5.31 in-lbs (0.5 to 0.6 Nm).

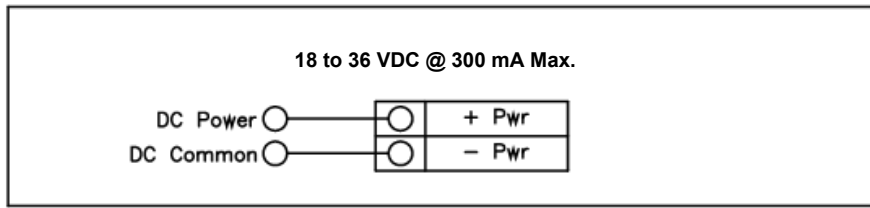

Figure 29. DC Power Connections



WARNING

Use a Class 2 isolated power supply that is grounded, provides DC output, and has no more than 10% output ripple.



CAUTION

The AC wire insulation temperature rating must meet or exceed 90°C (194°F), maximum operating voltage 600 VRMS.

2.7.2 4-20 mA Output Connections

The externally powered versions of the meters have a single 4-20 mA loop powered output. Two additional loops are available on the optional communication board. The 4-20 mA loop current is controlled by the meter electronics. The electronics must be wired in series with the sense resistor or current meter. The current control electronics require a minimum of 12 volts at the input terminals to operate correctly.

The maximum loop resistance (load) for the current loop output is dependent upon the supply voltage and is given in Figure 30. The 4-20 mA loop is optically isolated from the flow meter electronics.

R_{load} is the total resistance in the loop, including the wiring resistance ($R_{load} = R_{wire} + R_{sense}$). To calculate R_{max} , the maximum R_{load} for the loop, subtract the minimum terminal voltage from the supply voltage and divide by the maximum loop current, 20 mA. Thus:

$$\text{The maximum resistance } R_{load} = R_{max} = (V_{supply} - 12V) / 0.020 \text{ A}$$

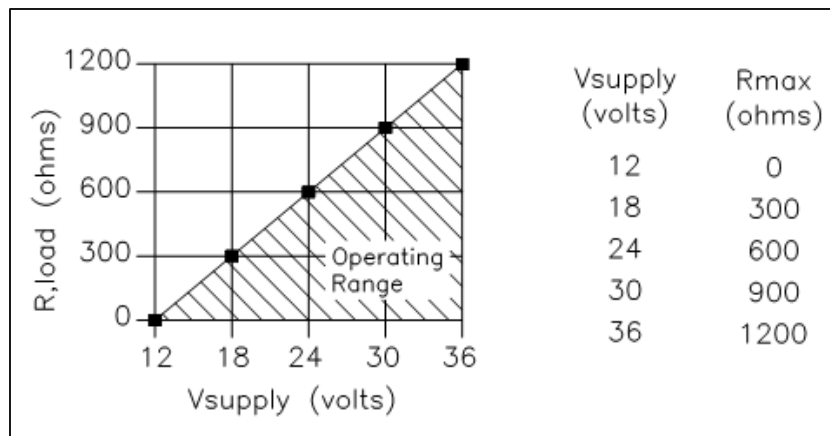

Figure 30. Load Resistance Versus Input Voltage

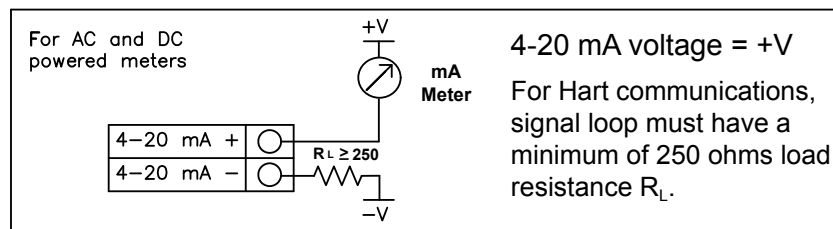

Figure 31. Isolated 4-20 mA Output Using External Power Supply

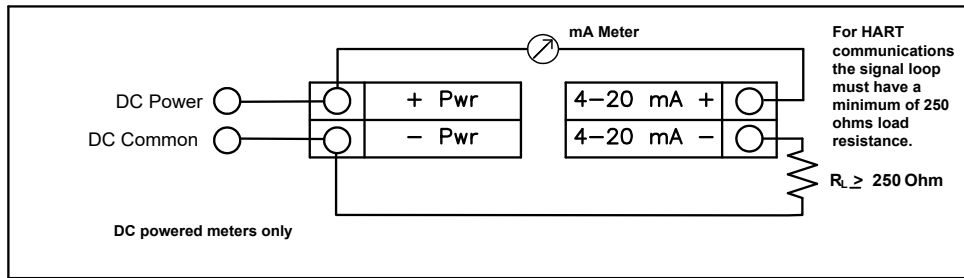

Figure 32. Non-Isolated 4–20 mA Output Using Meter Input Power Supply

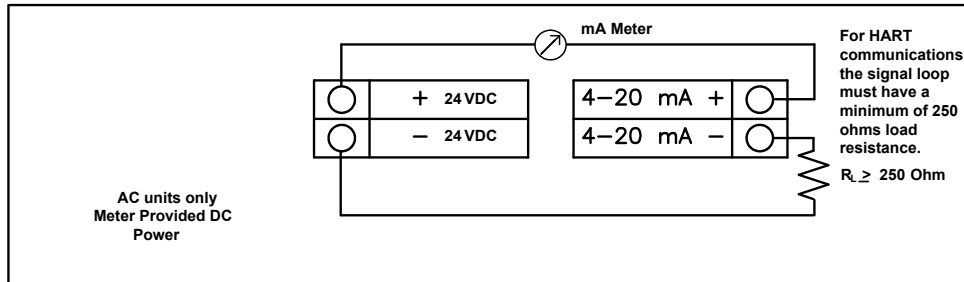

Figure 33. Isolated 4–20 mA Output Using Meter Provided Power Supply

2.7.3 Frequency Output Connections

The frequency output is used for a remote counter. It can be scaled to output a 1 to 10 kHz signal proportional to mass or volume flow, temperature, pressure or density.

The frequency output requires a separate 5 to 36 VDC power supply; however, there are current and power specifications that must be observed. The output can conduct a current up to 40 mA and can dissipate up to 200 mW. The output is isolated from the meter electronics and power supply.

There are three connection options for the frequency output. The first has a separate power supply (Figure 36). The second uses the flow meter power supply (Figure 37) (DC powered units only), and the third uses the internal 24 VDC power supply (Figure 38) (AC powered units only). Use the first option with a separate power supply (5 to 36 VDC) if a specific voltage is needed for the frequency output. Use the second configuration if the voltage at the flow meter power supply is an acceptable driver voltage for the load connected. (Take into account that the current used by the frequency load comes from the meter's power supply). Use the third configuration if you have an AC powered unit only. In any case, the voltage of the frequency output is the same as the voltage supplied to the circuit.

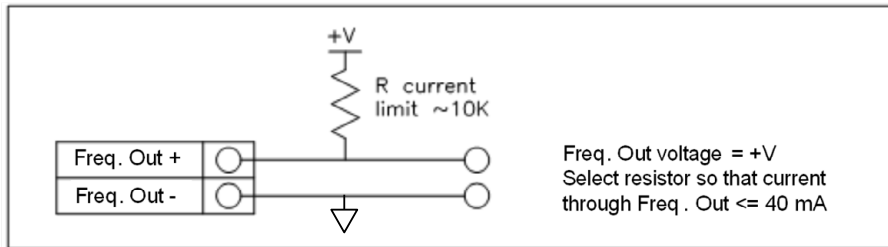

Figure 34. Isolated Frequency Output Using External Power Supply

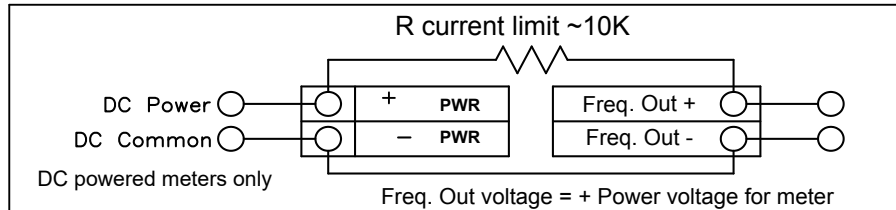

Figure 35. Non-Isolated Frequency Output Using Input Power Supply

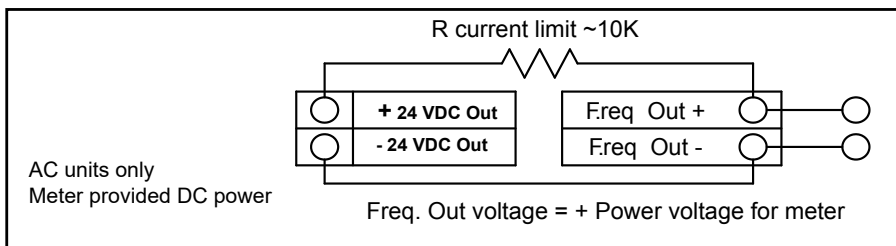

Figure 36. Isolated Frequency Output Using Meter Provided Power Supply

2.7.4 Pulse Output Connections

The pulse output is used for a remote counter. When the preset volume or mass (defined in the totalizer settings, on page 62) has passed the meter, the output provides a 50 millisecond square pulse.

The pulse output optical relay is a normally-open single-pole relay. The relay has a nominal 200 V / 160 ohm rating. This means that it has a nominal on-resistance of 160 ohms, and the largest voltage that it can withstand across the output terminals is 200 V. However, there are current and power specifications that must be observed. The relay can conduct a current up to 40 mA and can dissipate up to 320 mW. The relay output is isolated from the meter electronics and power supply.

There are three connection options for the pulse output. The first had a separate power supply (Figure 34). The second uses the flow meter power supply (Figure 35) (DC powered units only), and the third uses the internal 24 VDC power supply (Figure 2-32)(AC powered units only). Use the first option with a separate power supply (5 to 36 VDC) if a specific voltage is needed for the pulse output. Use the second configuration if the voltage at the flow meter power supply is an acceptable driver voltage for the load connected. (Take into account that the current used by the pulse load comes from the meter's power supply). Use the third configuration if you have an AC powered unit only. In any case, the voltage of the pulse output is the same as the voltage supplied to the circuit.

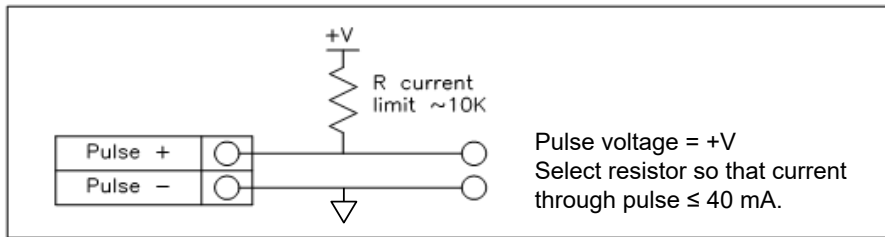

Figure 37. Isolated Pulse Output Using External Power Supply

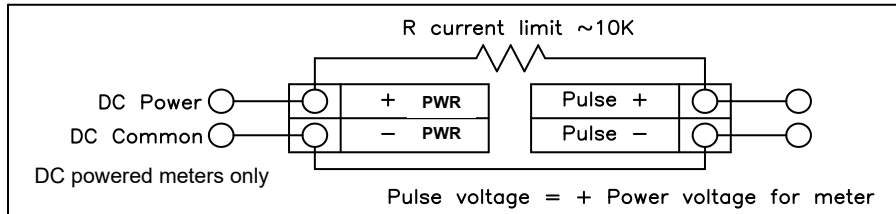

Figure 38. Non-Isolated Pulse Output Using Input Power Supply

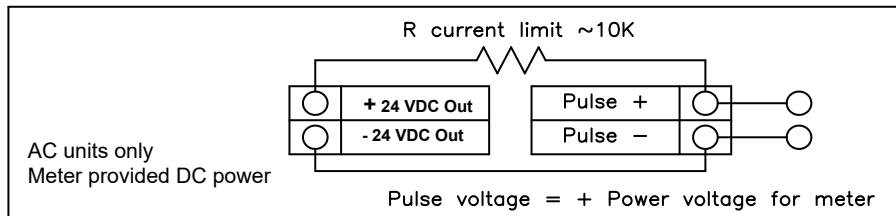

Figure 39. Isolated Pulse Output Using Meter Provided Power Supply

2.7.5 Alarm Output Connections

One alarm output (Alarm 1) is included on the standard meter. Two or more alarms (Alarm 2 and Alarm 3) are included on the optional communication board. The alarm output optical relays are normally open single-pole relays. The relays have a nominal 200 V / 160 ohm rating. This means that each relay has a nominal on-resistance of 160 ohms and the largest voltage that it can withstand across the output terminals is 200 V. However, there are current and power specifications that must be observed. The relay can conduct a current up to 40 mA and can dissipate up to 320 mW. The relay output is isolated from the meter electronics and power supply. When the alarm relay is closed, the current draw will be constant. Make sure to size Rload appropriately.

There are three connection options for the alarm output. The first has separate power supply (Figure 37). The second uses the flow meter power supply (Figure 38) (DC powered units only) and the third uses the meter provided power supply (Figure 39)(AC powered units only). Use the first option with a separate power supply (5 to 36 VDC) if a specific voltage is needed for the alarm output. Use the second configuration if the voltage at the flow meter power supply is an acceptable driver voltage for the load connected. (Take into account that the current used by the alarm load comes from the meter's power supply). Use the third if you have an AC powered unit only. In any case, the voltage of the alarm output is the same as the voltage supplied to the circuit.

The alarm output is used for transmitting high or low process conditions as defined in the alarm settings (see page 61).

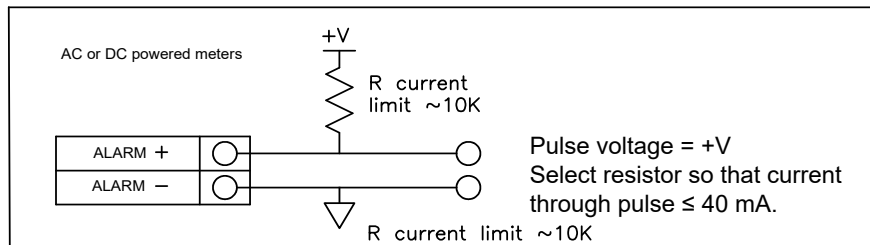

Figure 40 Isolated Alarm Output Using External Power Supply

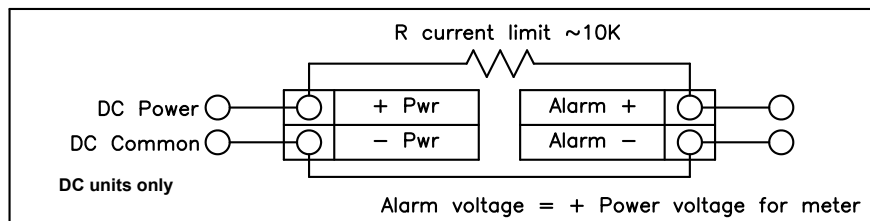

Figure 41. Non-Isolated Alarm Output Using Internal Power Supply

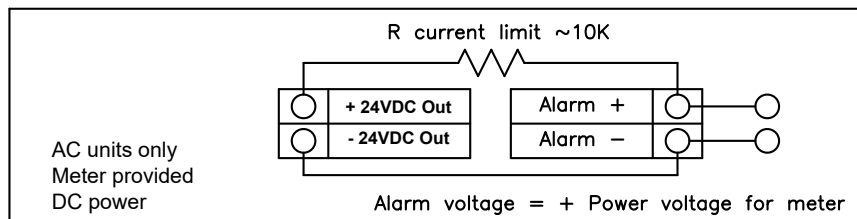

Figure 42. Isolated Alarm Output Using Meter Provided Power Supply

2.7.6 Remote Electronics Wiring

The remote electronics enclosure should be mounted in a convenient, easy to reach location. For hazardous location installations, make sure to observe agency requirements for installation. Allow some slack in the interface cable between the junction box and the remote electronics enclosure. To prevent damage to the wiring connections, do not put stress on the terminations at any time.

The meter is shipped with temporary strain relief glands at each end of the cable. Disconnect the cable from the meter's terminal block inside the junction box, not at the remote electronics enclosure. Remove both glands and install appropriate conduit entry glands and conduit. When installation is complete, re-connect each labeled wire to the corresponding terminal position on the junction box terminal block. Make sure to connect each wire pair's shield. Note: Incorrect connection will cause the meter to malfunction.

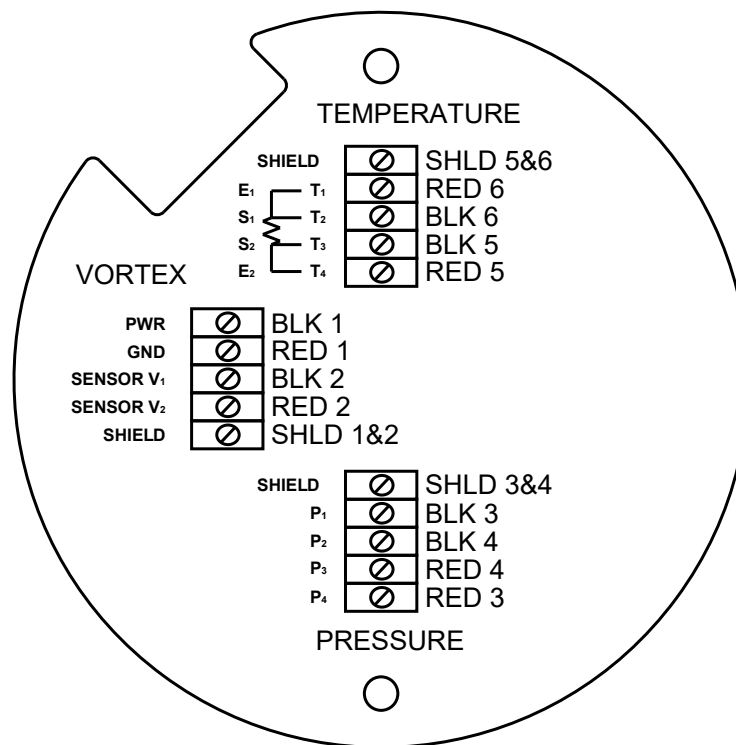

Figure 43. High Power Flow Meter Junction Box Sensor Connections



IMPORTANT NOTE

Numeric code in junction box label matches wire labels.

2.7.7 Optional Input Electronics Wiring

The meter has two optional input wiring terminals. These can be used to input a remote or second RTD input in the case of an energy monitoring meter, for the input of a remote pressure transducer, to pass a contact closure or for a remote density measurement to name a few. In any case, the wiring diagram will be included with the meter if any of the options are specified. Otherwise, the optional terminal blocks will be left blank and non-functional.

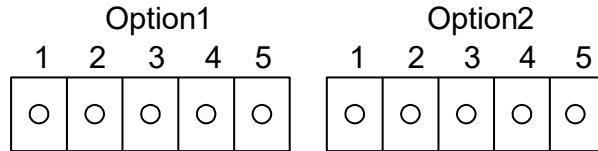

2.7.8 Optional Energy EMS RTD Input Wiring

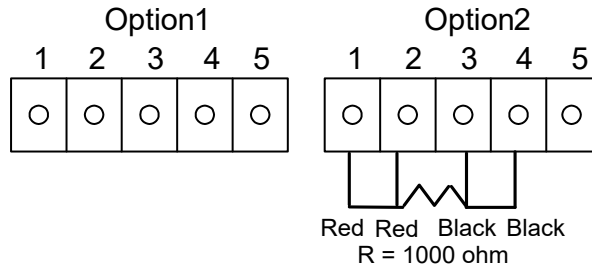

Figure 44. Optional Energy EMS RTD Input Wiring

The recommended customer supplied second RTD is a Class A 1000 ohm 4-wire platinum RTD. If a second RTD is not being used, then the factory supplied 1000 ohm resistor needs to be installed in its place.

2.7.9 Optional External 4-20 mA Input Wiring

The meter is set to have Option 1 used for the external input. Programming menus that pertain to the optional 4-20 mA input are located in the Hidden Diagnostics Menu in section 5.

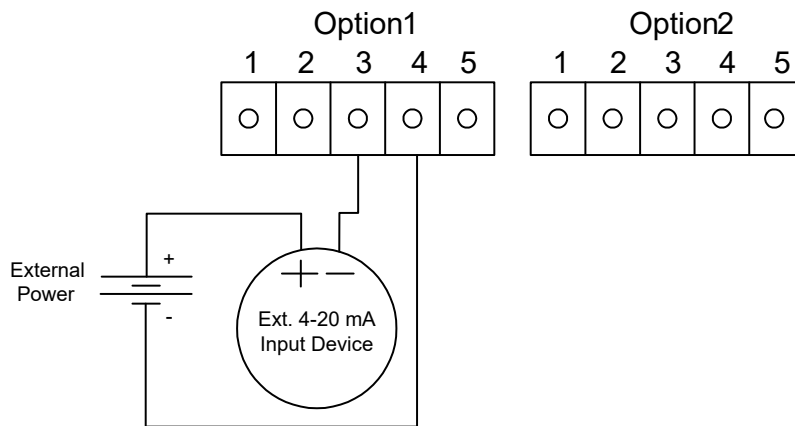

Figure 45. External 4-20 mA Input Wiring - External Power Supply

Follow the above diagram to wire the external 4-20 mA input into the flow meter using an external power supply.

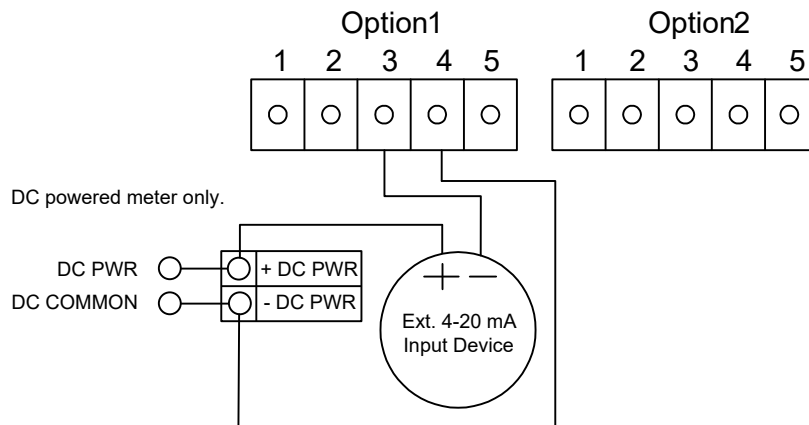

Figure 46. External 4-20 mA Input Wiring - DC Powered Meter

Follow the above diagram to wire the external 4-20 mA input into the flow meter using power supplied to the input of a DC powered meter.

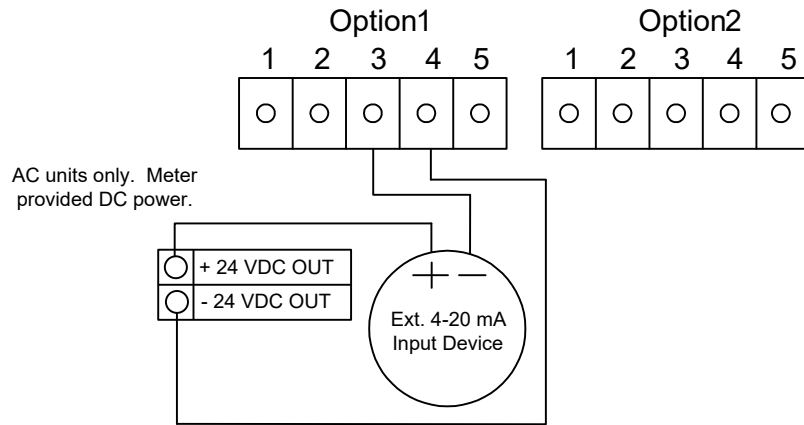

Figure 47. External 4-20 mA Input Wiring - AC Powered Meter

Follow the above diagram to wire the external 4-20 mA input into the flow meter using power from the 24 VDC output of an AC powered meter.

2.7.10 Optional Contact Closure Input Wiring

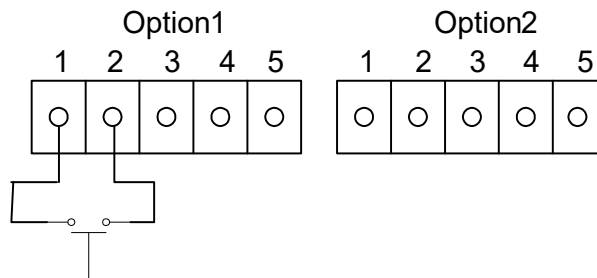

Figure 48. Optional Contact Closure Input Wiring

Follow the above diagram to wire an external switch input into the flow meter. The meter is configured to have Option 1 used for the external input. If the above switch is used to remotely reset the totalizer, a push button switch with a momentary contact closure is recommended.

SECTION 3: OPERATING INSTRUCTIONS

After installing the vortex flow meter, you are ready to begin operation. The sections in this chapter explain the display/keypad commands, meter start-up and programming. The meter is ready to operate at start-up without any special programming. To enter parameters and system settings unique to your operation, see the following pages for instructions on using the set-up menus.



WARNING

Do not open covers when an explosive atmosphere may be present.

3.1 FLOW METER DISPLAY/KEYPAD

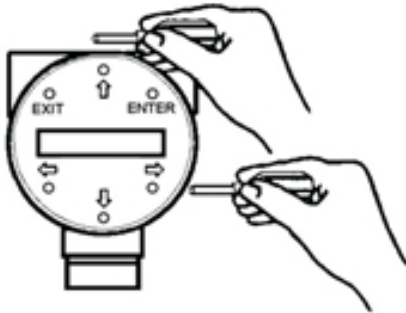

The flow meter's digital electronics allow you to set, adjust and monitor system parameters and performance. A full range of commands are available through the display/keypad. The LCD display gives 2 x 16 characters for flow monitoring and programming. The six push-buttons can be operated with the enclosure cover removed. Or, the explosion proof cover can remain in place and the keypad operated with a hand-held magnet positioned at the side of the enclosure as shown in the illustration at the left. To secure the enclosure cover use a 1/16" hex wrench to tighten the 6-32 x 1/4 cup point socket set locking screw.

Display/Keypad Commands

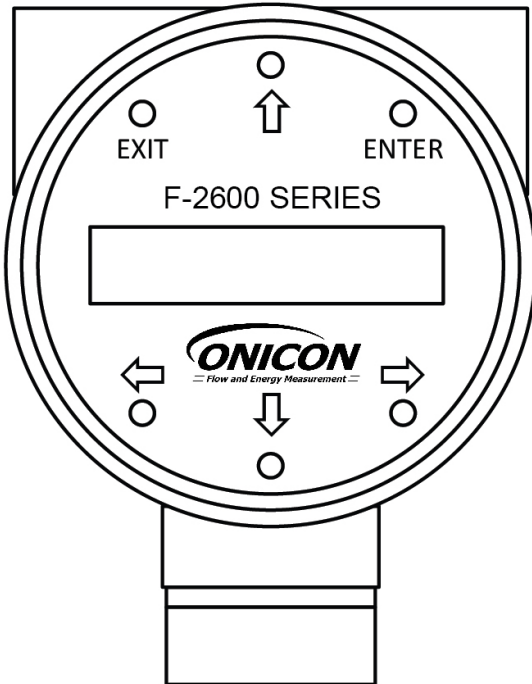

From the Run Mode, the **ENTER** key allows access to the Set-up Menus (through a password screen). Within the Set-up Menu (through a password screen). Within the Set-up Menu, pressing **ENTER** activates the current field. To set new parameters, press the **ENTER** key until an underline cursor appears. Use the \uparrow \downarrow \leftarrow \rightarrow keys to select new parameters. Press **ENTER** to continue. (If change is not allowed, **ENTER** has no effect.) All outputs are disabled when using the Set-up Menus.

The **EXIT** key is active within the Set-up Menus. When using a Set-up Menu, **EXIT** returns you to the Run Mode. If you are changing a parameter and make a mistake, **EXIT** allows you to start over.

The \uparrow \downarrow \leftarrow \rightarrow keys advance through each screen of the current menu. When changing a system parameter, all \uparrow \downarrow \leftarrow \rightarrow keys are available to enter new parameters.

Figure 49. Flow Meter Display/Keypad

3.2 START-UP

To begin flow meter operation:

1. Verify the flow meter is installed and wired as described in Section 2.
2. Apply power to the meter. At start-up, the unit runs a series of self-tests that check the RAM, ROM, EPROM and all flow sensing components. After completing the self-test sequence, the Run Mode screens appear.
3. The flow meter display contrast is set at the factory but if the display characters appear too dark or too light proceed as follows:
 - A. Hold down the “Exit” button on the front panel for 5 to 10 seconds. “Setting Contrast” will appear.
 - B. Push the “Up” arrow to darken the display or the “Down” arrow to lighten it.
 - C. Push the “Enter” button to save the contrast setting.
4. The Run Mode displays flow information as determined by system settings. Some screens depicted on the next page may not be displayed based on these settings. Press the $\uparrow \downarrow$ arrow keys to view the Run Mode screens.
5. Press the ENTER key from any Run Mode screen to access the Set-up Menus. Use the Set-up Menus to configure the meter’s multi-parameter features to fit your application.



IMPORTANT NOTICE

Starting the flow meter or pressing EXIT will always display the Run Mode screens.

Run Mode Screens

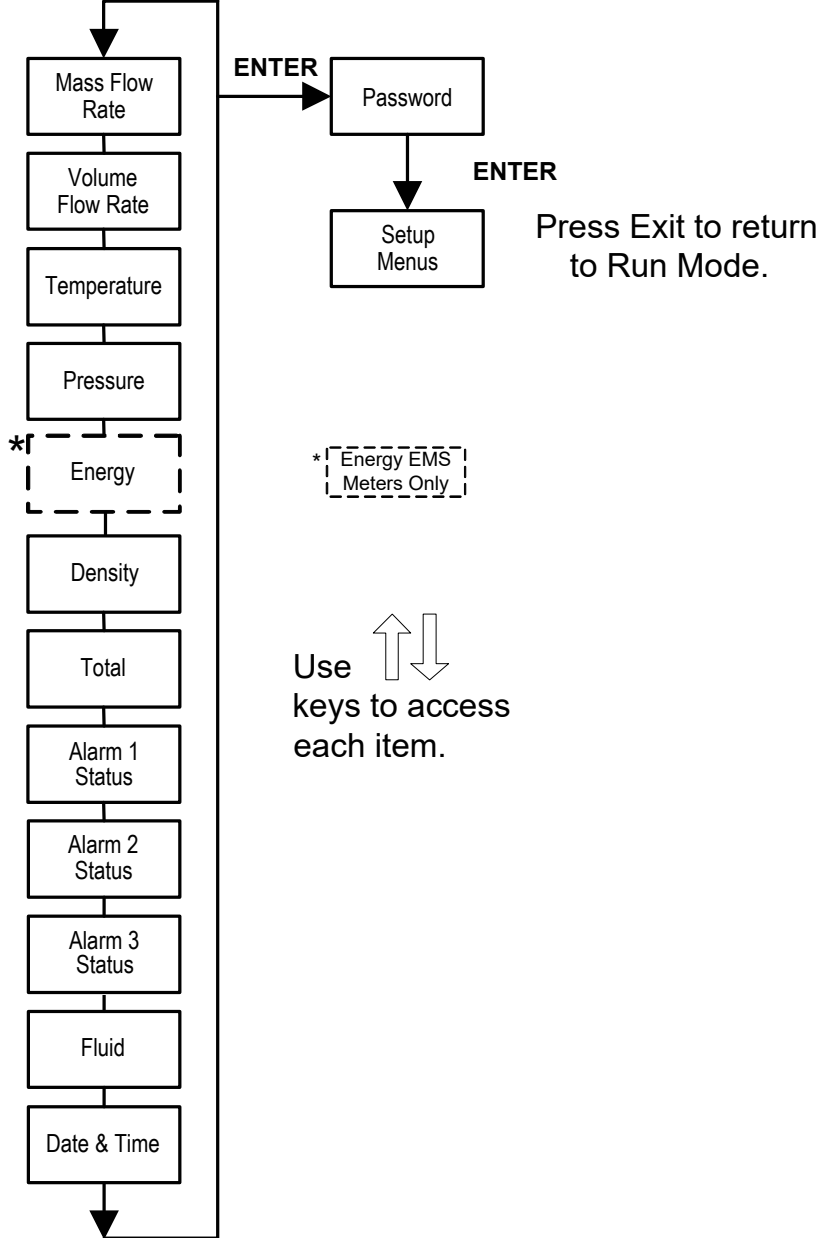

3.3 USING THE SET-UP MENUS

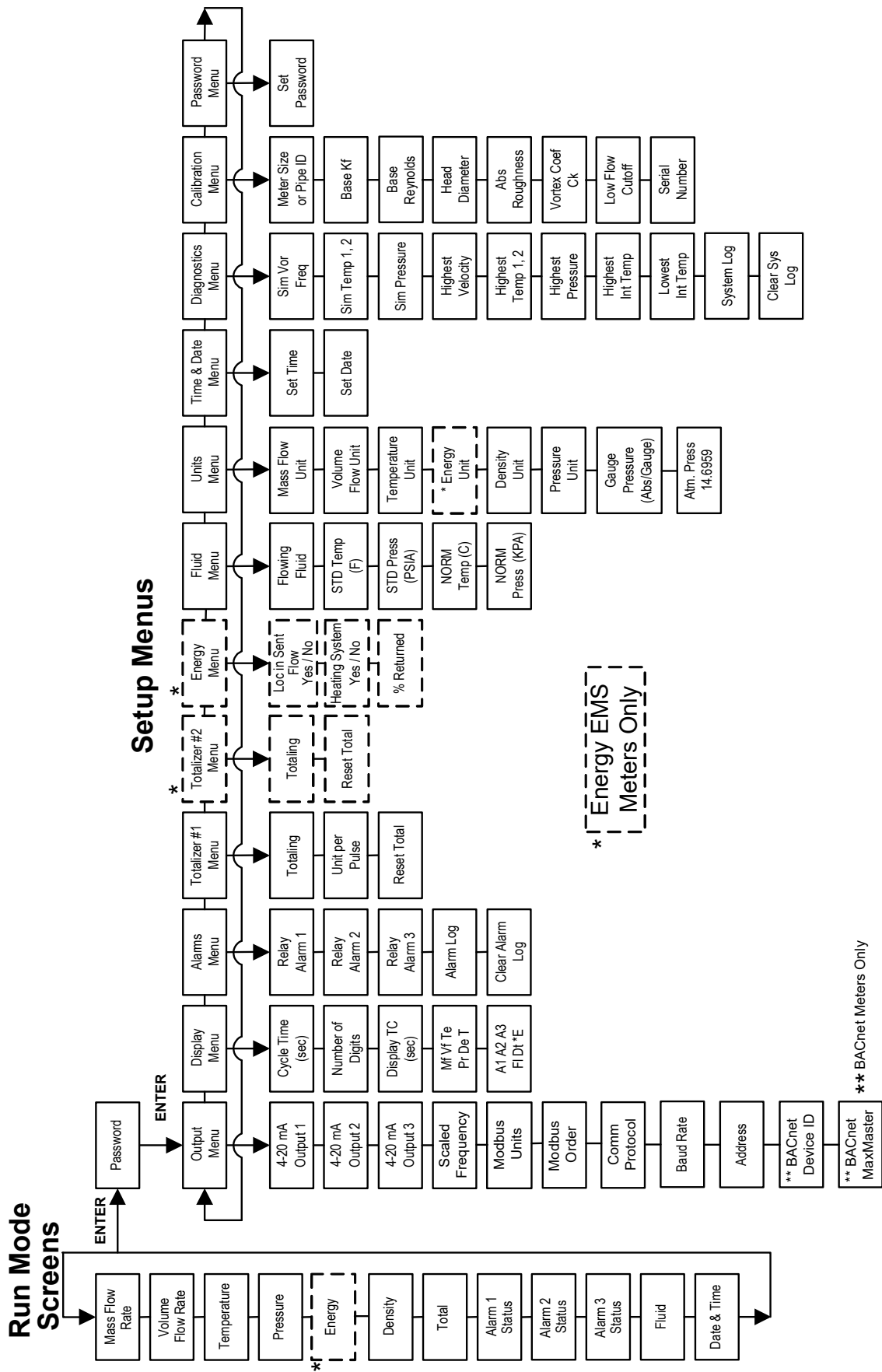

3.3.1 Programming the Flow Meter

1. Enter the Set-up Menu by pressing the ENTER key until prompted for a password. (All outputs are disabled while using the Set-up Menus.)
2. Use the $\uparrow \downarrow \leftarrow \rightarrow$ keys to select the password characters (1234 is the factory-set password). When the password is correctly displayed, press ENTER to continue.
3. Use the Set-up Menus described on the following pages to customize the multiparameter features of F-2600 & F-2700 Flow Meters. (The entire lower display line is available for entering parameters.) Some items depicted in the graphic on the preceding page may not be displayed based on flow meter configuration settings.
4. To activate a parameter, press ENTER. Use the $\uparrow \downarrow \leftarrow \rightarrow$ keys to make selections. Press ENTER to continue. Press EXIT to save or discard changes and return to Run Mode.
5. Program the UNITS menu first because later menus will be based on the units selected.

3.3.2 Output Menu

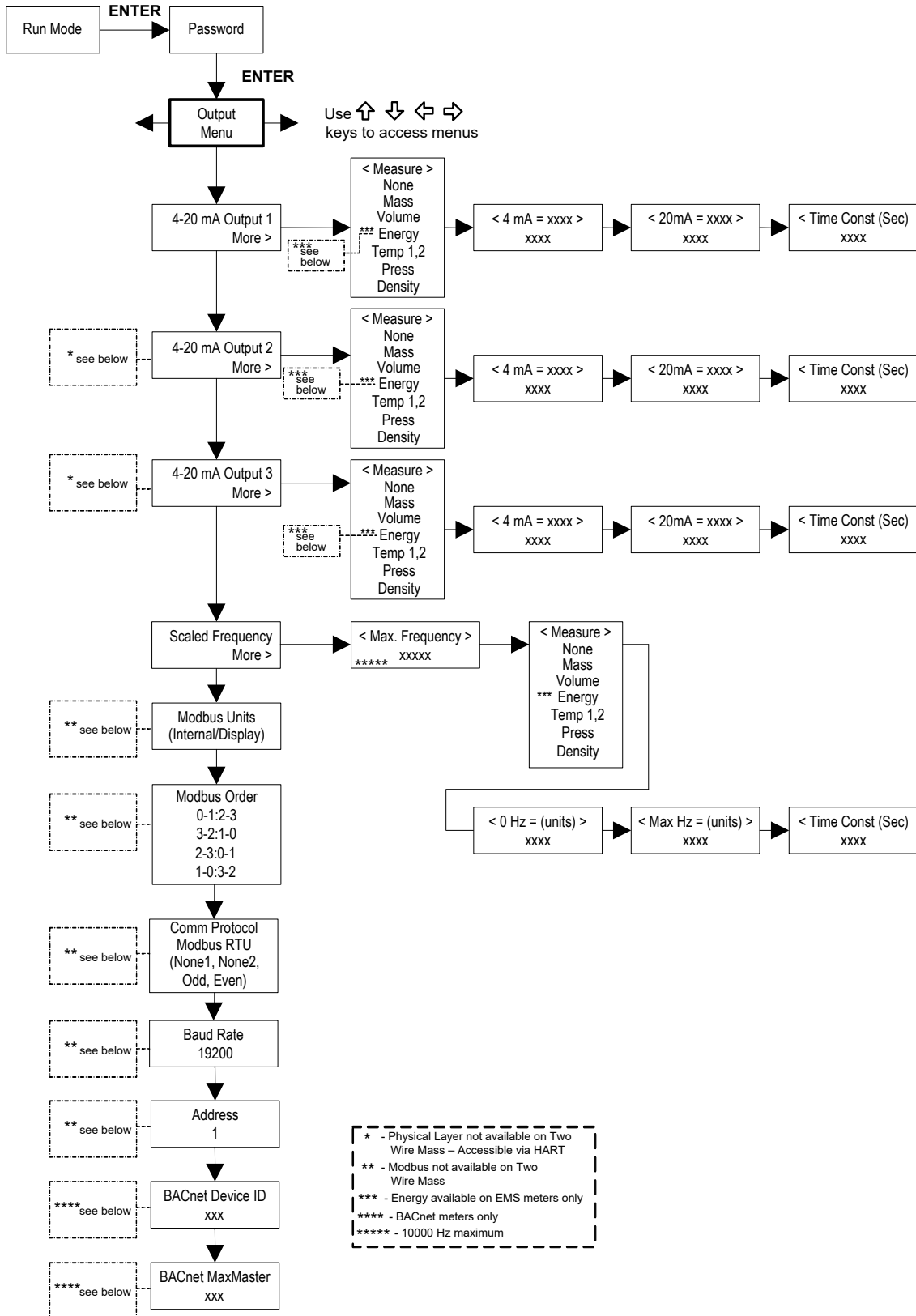

Example for Setting an Output

The following shows how to set Output 1 to measure mass flow with 4 mA = 0 lb/hr and 20 mA = 100 lb/hr with a time constant of five seconds. (All outputs are disabled while using the Set-up Menus.)

First, set the desired units of measurement:

1. Use $\leftarrow \Rightarrow$ keys to move to the Units Menu (see page 64).
2. Press \Downarrow key until Mass Flow Unit appears. Press ENTER.
3. Press \Downarrow key until lb appears in the numerator. Press \Rightarrow key to move the underline cursor to the denominator. Press the \Downarrow key until hr appears in the denominator. Press ENTER to select.
4. Press \Uparrow key until Units Menu appears.

Second, set the analog output:

1. Use $\leftarrow \Rightarrow$ keys to move to the Output Menu.
2. Press the \Downarrow key until 4-20 mA Output 1 appears.
3. Press \Downarrow key to access Measure selections. Press ENTER and press the \Downarrow key to select Mass. Press ENTER.
4. Press \Rightarrow key to set the 4 mA point in the units you have selected for mass of lb/hr. Press ENTER and use $\Uparrow \Downarrow \leftarrow \Rightarrow$ keys to set 0 or 0.0. Press ENTER.
5. Press \Rightarrow key to set the 20 mA point. Press ENTER and use $\Uparrow \Downarrow \leftarrow \Rightarrow$ keys to set 100 or 100.0. Press ENTER.
6. Press \Rightarrow key to select the Time Constant. Press ENTER and use $\Uparrow \Downarrow \leftarrow \Rightarrow$ keys to select 5. Press ENTER.
7. Press the EXIT key and answer YES to permanently save your changes.

3.3.3 Display Menu

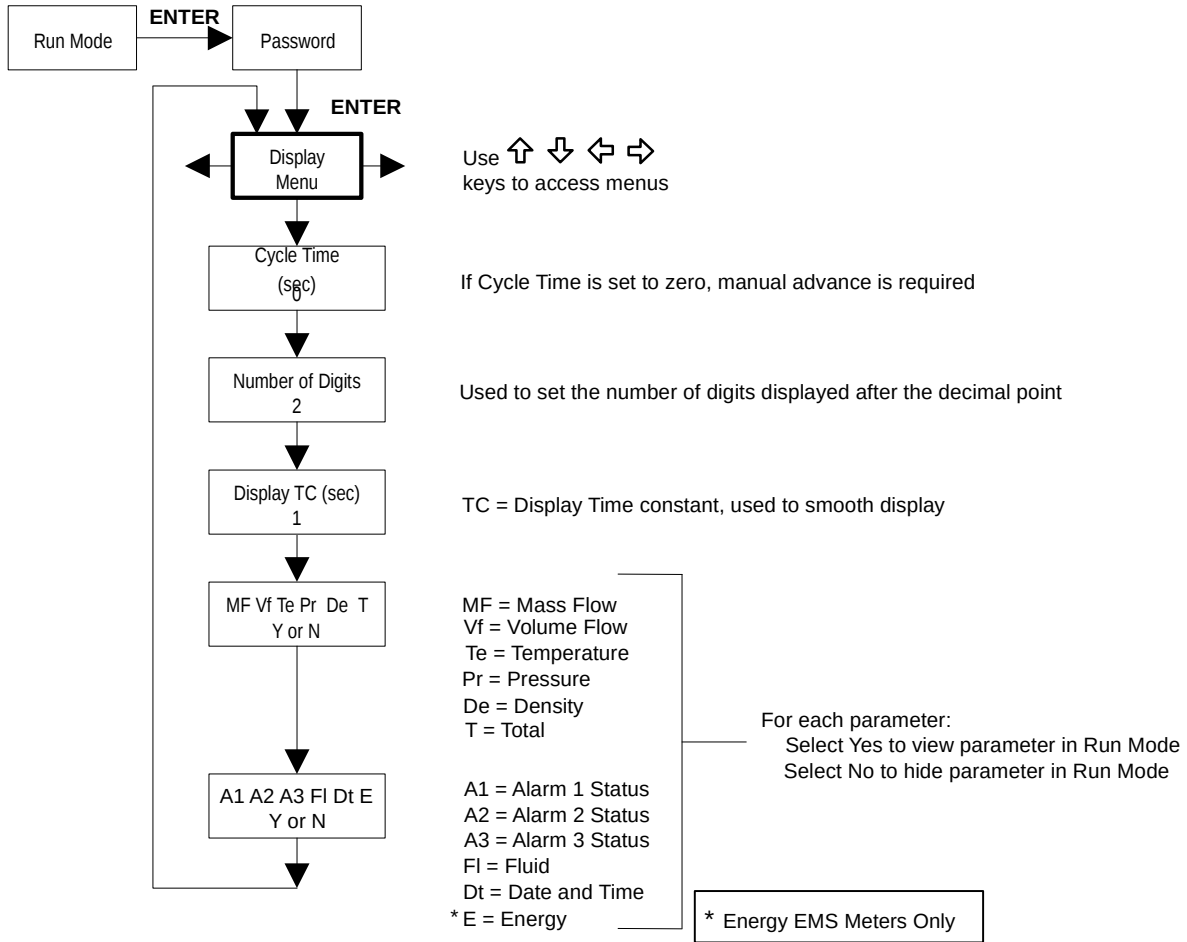

Use the Display Menu to set the cycle time for automatic screen sequencing used in the Run Mode, change the precision of displayed values, smooth the values or enable or disable each item displayed in the Run Mode screens.

Example for Changing a Run Mode Display Item

The following shows how to remove the temperature screen from the Run Mode screens.

Note: All outputs are disabled while using the Set-up Menus.

1. Use ⇐ ⇒ keys to move to the Display Menu.
2. Press ↓ key until Mf Vf Pr Te De T appears.
3. Press ENTER to select. Press ⇒ key until the cursor is positioned below Te.
4. Press ↓ key until N appears. Press ENTER to select.
5. Press EXIT and then ENTER to save changes and return to the Run Mode.

3.3.4 Alarms Menu

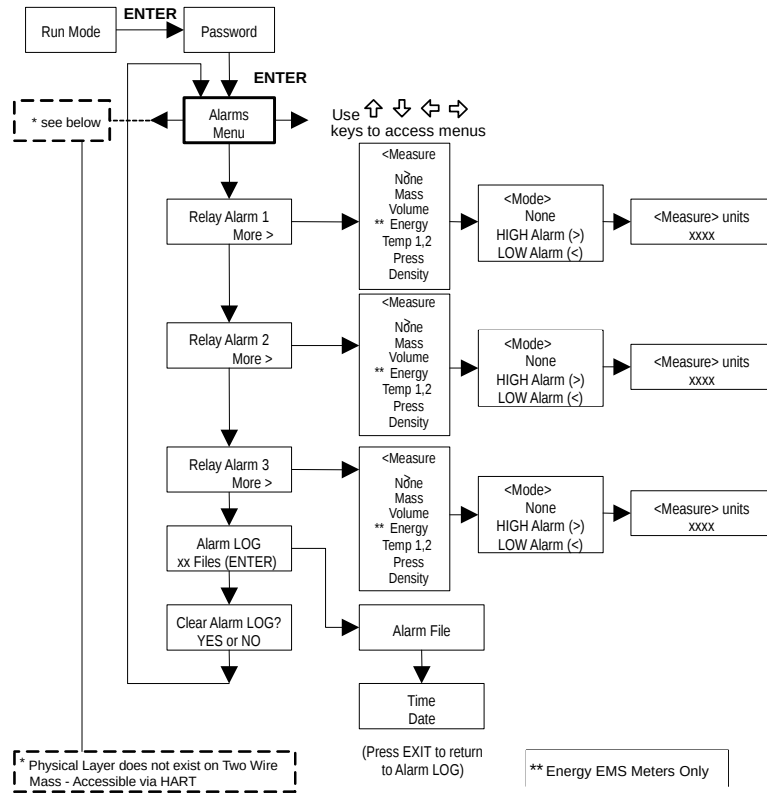

Example for Setting an Alarm

The following shows how to set Relay Alarm 1 to activate if the mass flow rate is greater than 100 lb/hr. You can check the alarm configuration in the Run Mode by pressing the ↑ ↓ keys until Alarm (1) appears. The lower line displays the mass flow rate at which the alarm activates. Note: All outputs are disabled while using the Set-up Menus.

First, set the desired units of measurement:

1. Use ⇐ ⇒ keys to move to the Units Menu (see to page 64).
2. Press ↓ key until Mass Flow Unit appears. Press ENTER.
3. Press ↓ key until lb appears in the numerator. Press ⇒ key to move the underline cursor to the denominator. Press the ↓ key until hr appears in the denominator. Press ENTER to select.
4. Press ↑ key until Units Menu appears.

Second, set the alarm:

1. Use ⇐ ⇒ keys to move to the Alarms Menu.
2. Press the ↓ key until Relay Alarm 1 appears.
3. Press ⇒ key to access Measure selections. Press ENTER and use the ↓ key to select Mass. Press ENTER.
4. Press ⇒ key to select the alarm Mode. Press ENTER and use ↓ key to select HIGH Alarm. Press ENTER.
5. Press ⇒ key to select the value that must be exceeded before the alarm activates. Press ENTER and use ↑ ↓ ⇐ ⇒ keys to set 100 or 100.0. Press ENTER.
6. Press the EXIT key to save your changes. (Alarm changes are always permanently saved. Up to three relay alarm outputs are available depending on meter configuration.)

3.3.5 Totalizer #1 Menu

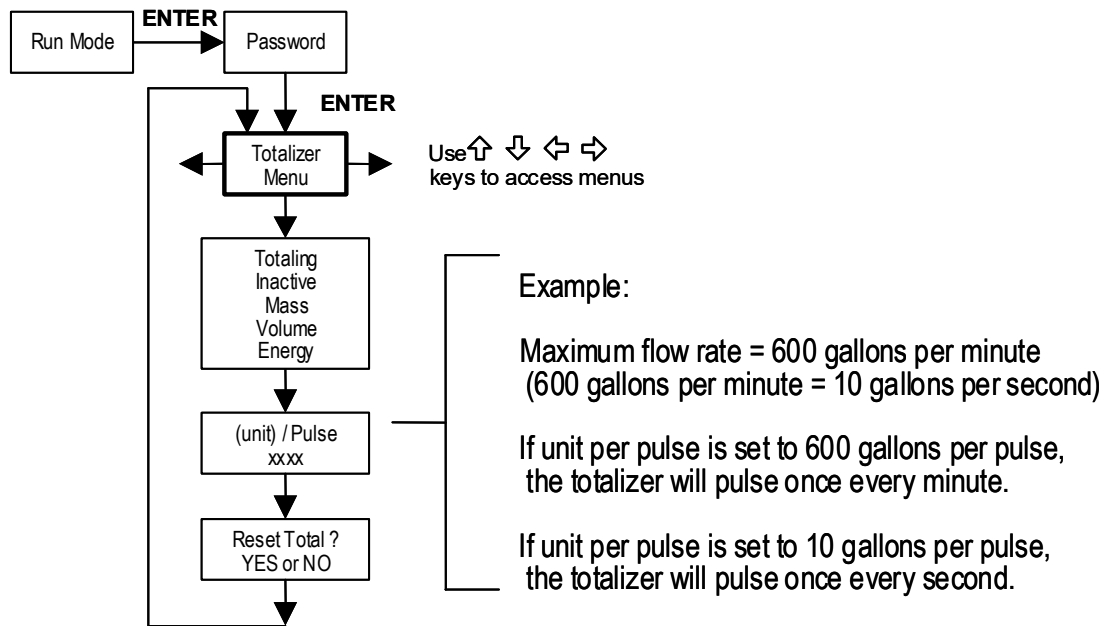

Use the Totalizer Menu to configure and monitor the totalizer. The totalizer maximum count is 999,999,999 at which point it will roll over to 0. The totalizer output is a 50 millisecond (.05 second) positive pulse (relay closed for 50 milliseconds). The totalizer cannot operate faster than one pulse every 100 millisecond (.1 second). A good rule to follow is to set the unit per pulse value equal to the maximum flow in the same units per second. This will limit the pulse to no faster than one pulse every second.

Example for Setting the Totalizer

The following shows how to set the totalizer to track mass flow in kg/sec. (All outputs are disabled while using the Set-up Menus.)

First, set the desired units of measurement:

1. Use $\leftarrow \Rightarrow$ keys to move to the Units Menu (see to page 64).
2. Press \Downarrow key until Mass Flow Unit appears. Press ENTER.
3. Press \Downarrow key until kg appears in the numerator. Press \Rightarrow key to move the underline cursor to the denominator. Press the \Downarrow key until sec appears in the denominator. Press ENTER to select.
4. Press \Uparrow key until Units Menu appears.

Second, set the pulse output:

1. Use $\leftarrow \Rightarrow$ keys to move to the Totalizer Menu.
2. Press the \Downarrow key until Totaling appears.
3. Press ENTER and press the \Downarrow key to select Mass. Press ENTER.
4. Press \Downarrow key to set the pulse output in the units you have selected for mass flow of kg/sec. Press ENTER and use $\Uparrow \Downarrow \leftarrow \Rightarrow$ keys to set the pulse value equal to the maximum flow in the same units per second. Press ENTER.
5. To reset the totalizer, press \Downarrow key until Reset Total? Appears. Press ENTER and the \Downarrow key to reset the totalizer if desired. Press ENTER.
6. Press the EXIT key and answer YES to permanently save your changes.

3.3.6 Totalizer #2 Menu

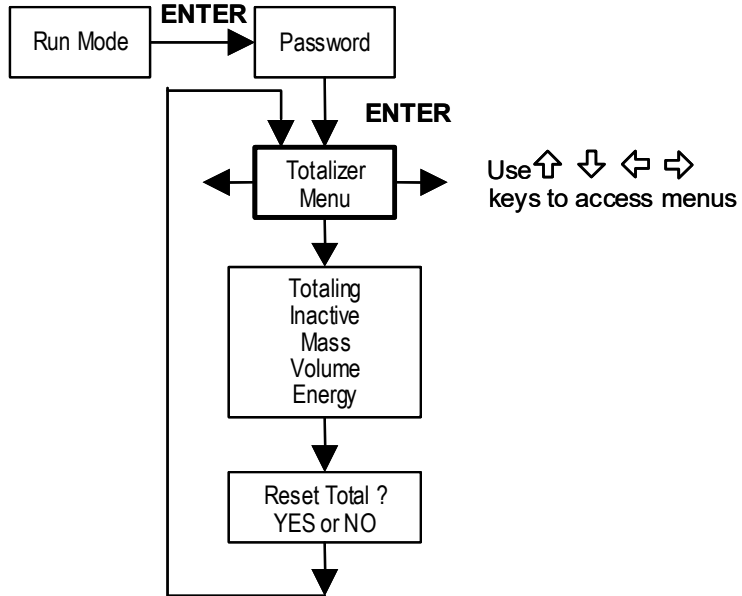

Use the Totalizer #2 to monitor flow or energy. The totalizer maximum count is 999,999,999 at which point it will roll over to 0. Note that Totalizer #2 does not operate a relay. It is for monitoring only.

3.3.7 Energy Menu – For EMS Energy Meters Only

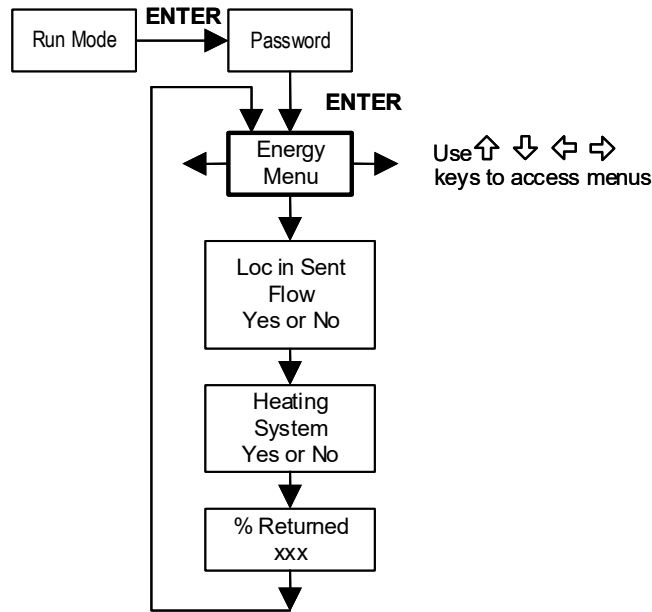

Configuration:

There are several possibilities regarding the measurement of water or steam energy given the location of the meter and the use of a second RTD. The table below summarizes the possibilities:

Fluid	Meter Location	Second RTD	Measurement
Water	“Sent” Flow Line	“Return” Flow Line	Change in Energy
Water	“Return” Flow Line	“Sent” Flow Line	Change in Energy
Water	“Sent” Flow Line	None	Outgoing Energy
Steam	“Sent” Flow Line	“Return” Flow Line (condensate)	Change in Energy
Steam	“Sent” Flow Line	None	Outgoing Energy

As above, you must properly configure the meter in the Energy Menu.

1. Loc in Sent Flow? Select Yes or No based on where the meter is located. Refer to the above table.
2. Heating System? Select Yes for a hot water system used for heating. Select No for a chilled water system used for cooling. Always select Yes for a steam system.
3. % Returned. Select a number between 0% and 100%. Estimate the amount of water that returns. It is usually 100%, or can be less than 100% if historical data shows the amount of makeup water used. If a second RTD is not used, set to 0%. When 0% is selected, the energy calculation represents the outgoing energy only (no return energy is subtracted).



IMPORTANT NOTICE

The meter ships from the factory assuming 0% return and has a 1000 ohm resistor installed in the RTD #2 wiring location. This needs to be removed if the meter is to be used in a manner other than with 0% return and with the customer supplied RTD in its place.

3.3.8 Fluid Menu

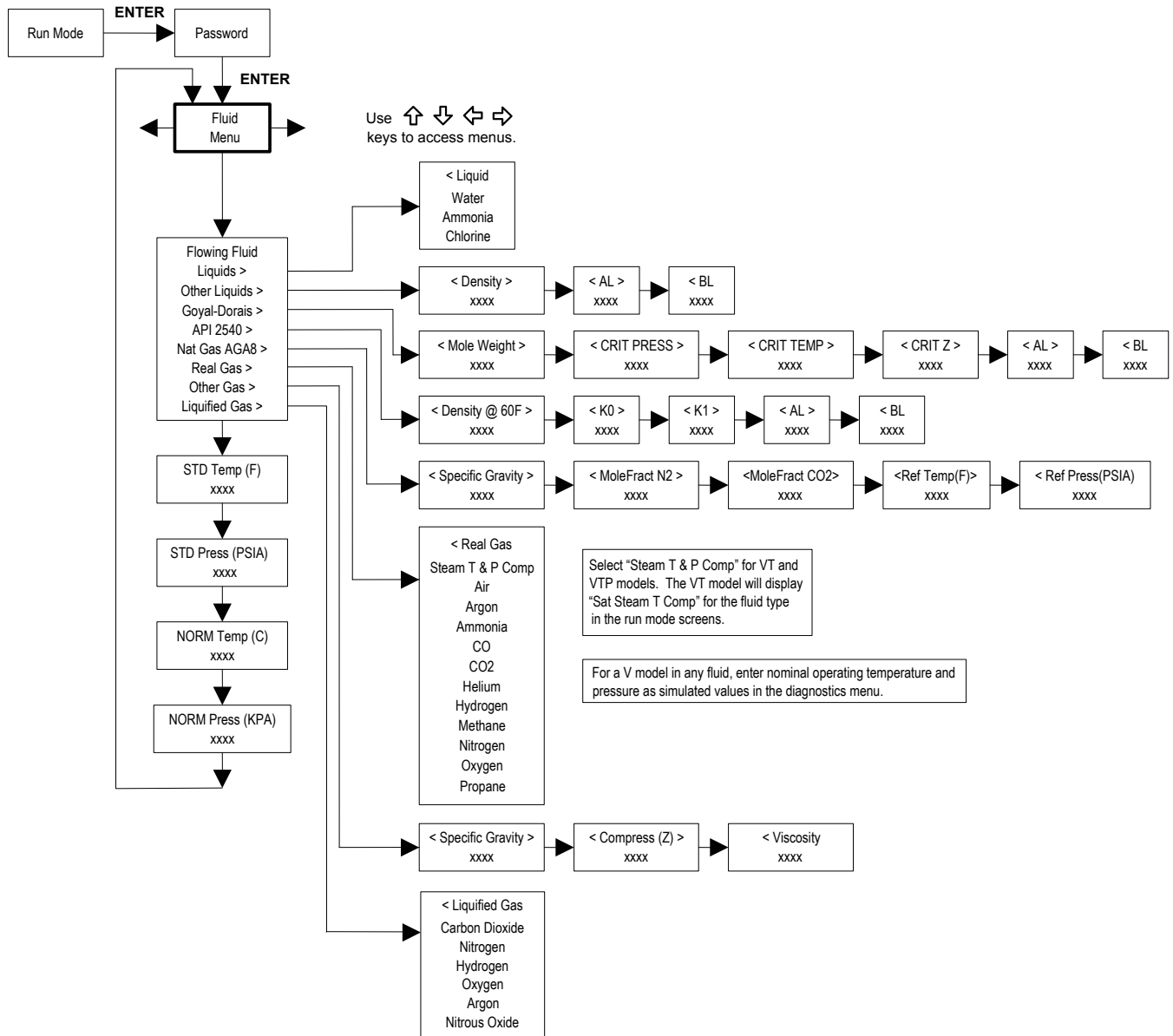

Use the Fluid Menu to configure the flow meter for use with common gases, liquids and steam. Your flow meter is pre-programmed at the factory for your application’s process fluid.

Reference Richard W. Miller, Flow Measurement Engineering Handbook (Third Edition, 1996), page 2-75 for definition and use of the Goyal-Doraiswamy equation and page 2-76 for the definition and use of the API 2540 equation. Also, see Appendix B for Fluid Calculation equations.

The units of measurement used in the Fluid Menu are preset and are as follows:
Mole Weight = lbm/(lbm•mol), CRIT PRESS = psia, CRIT TEMP = °R, Density = kg /m3 and Viscosity = cP (centipoise).

3.3.9 Units Menu

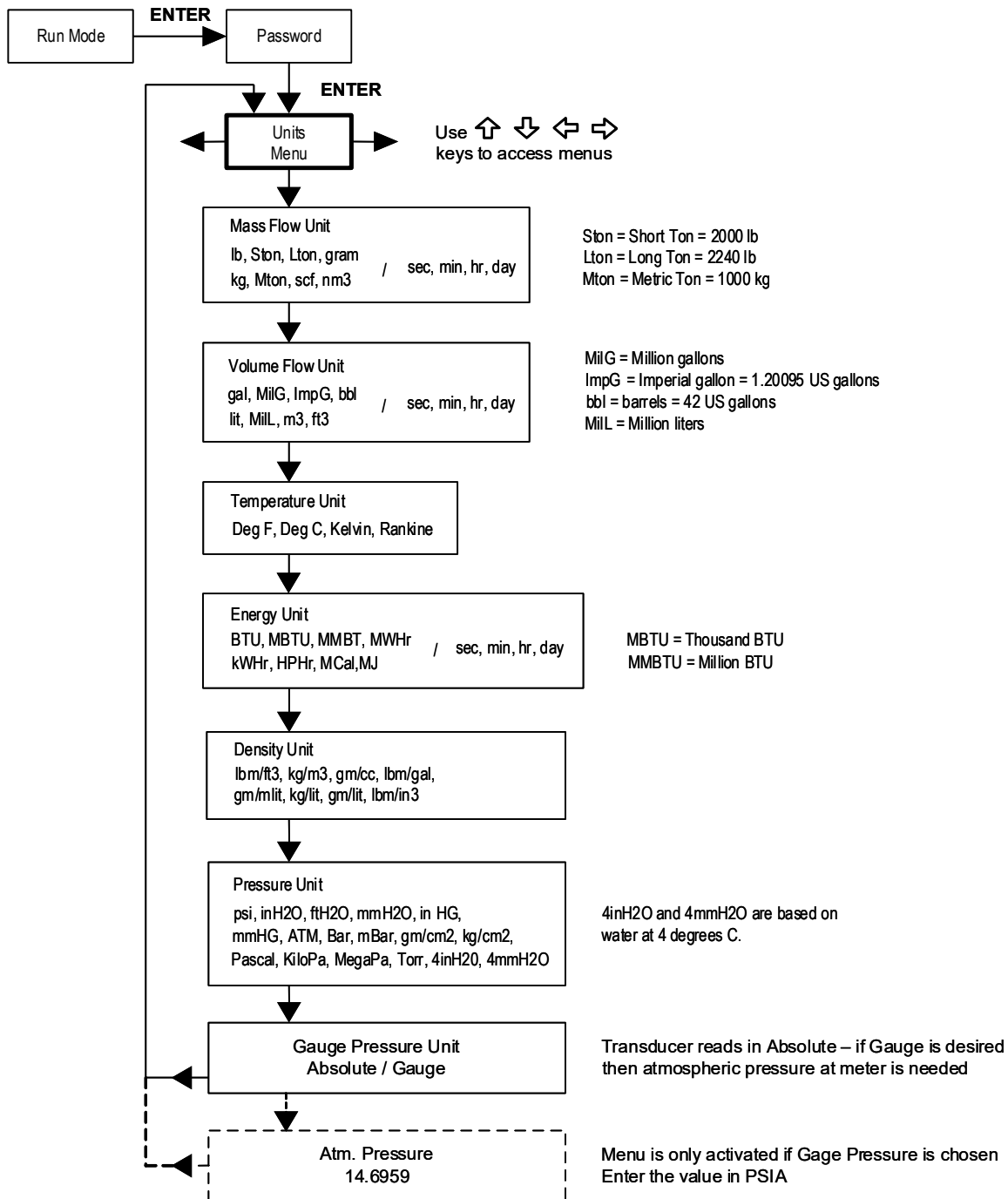

Use the Units Menu to configure the flow meter with the desired units of measurement. (These are global settings and determine what appears on all screens.)

3.3.10 Time & Date Menu

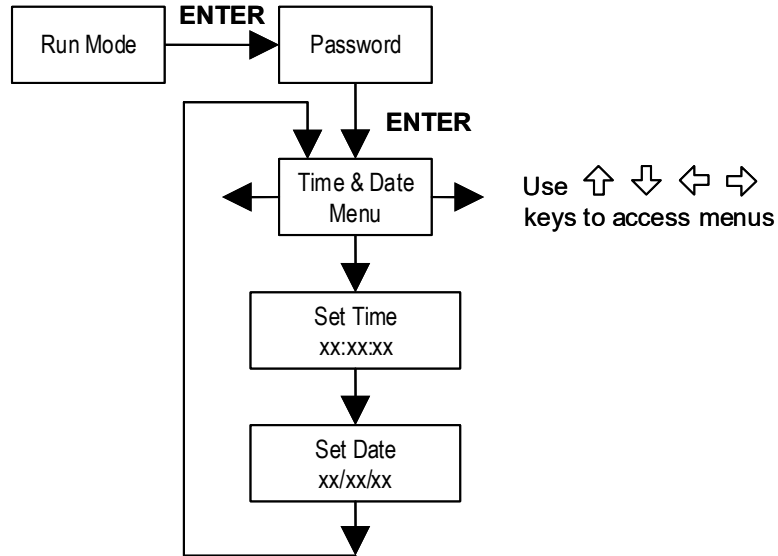

Use the Time and Date Menu to enter the correct time and date into the flow meter's memory. The parameters are used in the Run Mode and the alarm and system log files.



IMPORTANT NOTICE

Time is displayed in AM/PM format, but military format is used to set the time. For example; 1:00 PM is entered as 13:00:00 in the Set Time menu.

Example for Setting the Time

How to set the time to 12:00:00. You can check the time in the Run Mode by pressing the ↑ ↓ keys until the Time & Date screen appears. Note: All outputs are disabled while using the Set-up Menus.

1. Use ← ⇒ keys to move to the Time and Date Menu.
2. Press ↓ key until Set Time appears. Press ENTER.
3. Press ↓ key until 1 appears. Press ⇒ key to move the underline cursor to the next digit. Press the ↓ key until 2 appears. Continue sequence until all desired parameters are entered. Press ENTER to return to the Time and Date Menu.
4. Press **EXIT** to return to the Run Mode.

3.3.11 Diagnostics Menu

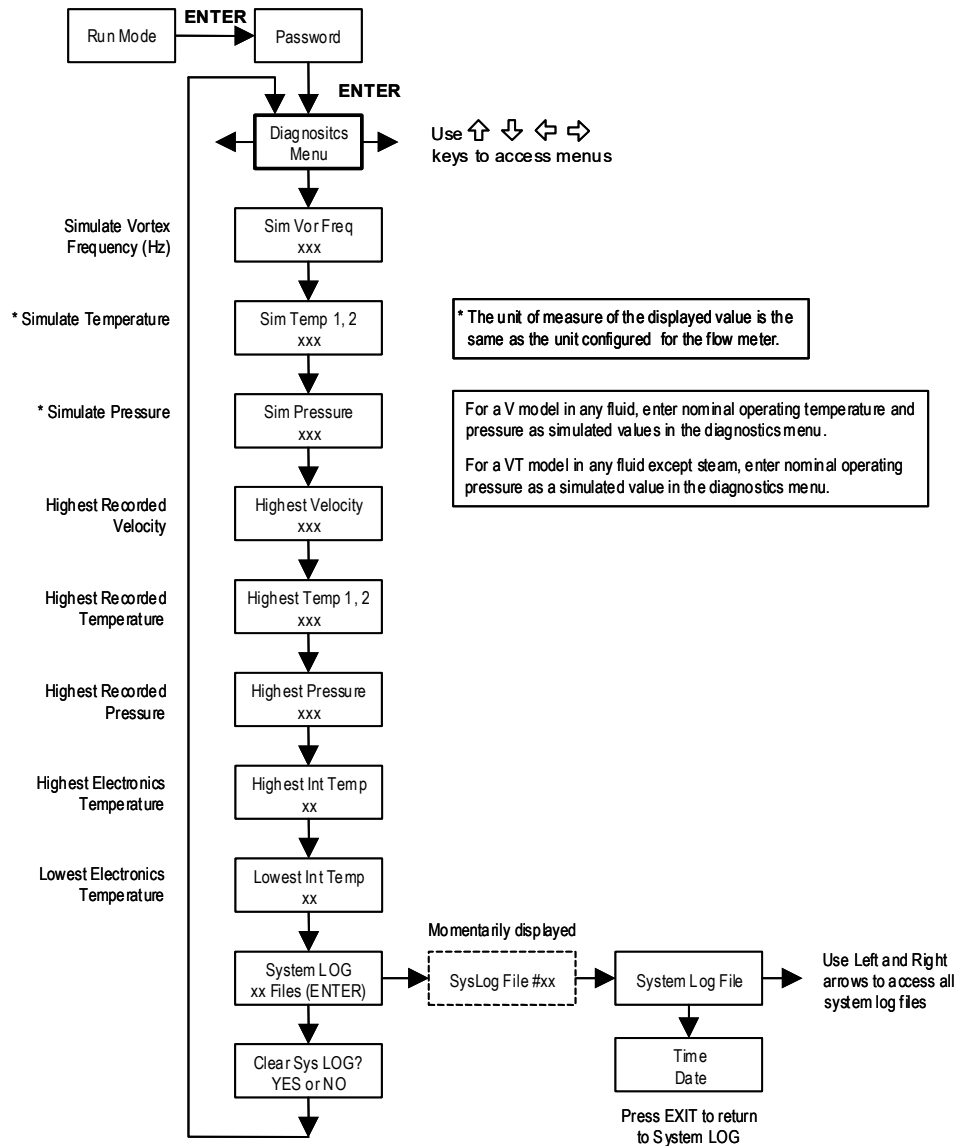

Use the Diagnostics Menu to simulate operation and review the system files. The system log files contain time/date stamped messages including: power on, power off, programming time outs, parameter faults, incorrect password entry and other various information relative to system operation and programming.

The simulated inputs are for testing the meter to verify that the programming is correct. They are also used to enter nominal operating temperature and pressure for the V (volumetric) only model. Simulated vortex frequency allows you to enter any value for the sensor input in Hz. The meter will calculate a flow rate based on the corresponding value and update all analog outputs. **The totalizer display and output is not affected by a simulated frequency.** The simulated pressure and temperature settings work the same way. The meter will output these new values and will use them to calculate a new density for mass flow measurement. Note: When your diagnostic work is complete, make sure to return the values to zero to allow the electronics to use the actual transducer values. For the V only model, keep the temperature and pressure at nominal operating conditions. If the meter display indicates a temperature or pressure fault, a substitute value can be entered to allow flow calculations to continue at a fixed value until the source of the fault is identified and corrected. **The units of measure of the displayed values are the same as the units configured for the flow meter.**

3.3.12 Calibration Menu

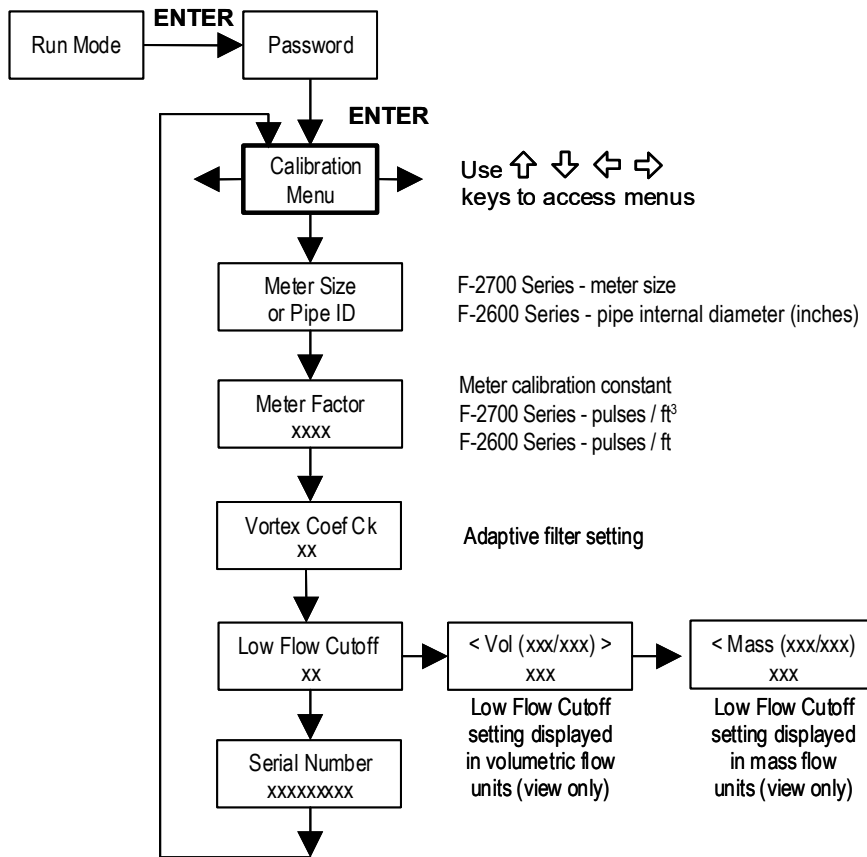

The Calibration Menu contains the calibration coefficients for the flow meter. These values should be changed only by properly trained personnel. The Vortex Coef Ck and Low Flow Cutoff are set at the factory. Consult the factory for help with these settings if the meter is showing erratic flow rate.

3.3.13 Password Menu

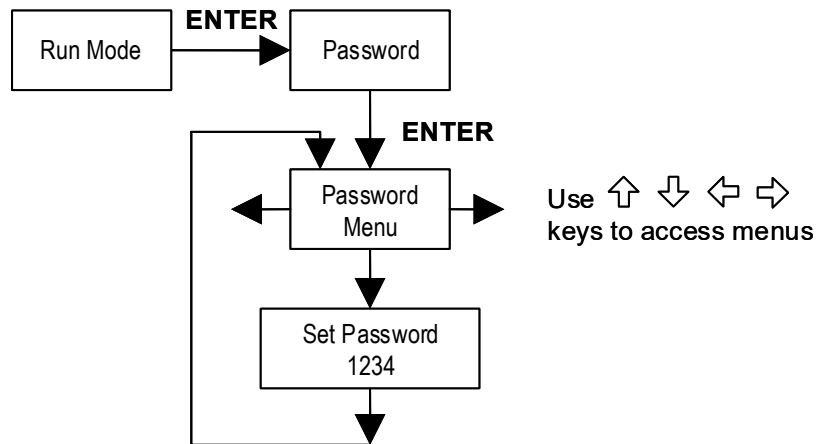

Use the Password Menu to set or change the system password. The factory-set password is 1234.

SECTION 4.0: SERIAL COMMUNICATIONS

4.1 HART COMMUNICATIONS

The HART Communications Protocol (Highway Addressable Remote Transducer Protocol) is a bidirectional digital serial communications protocol. The HART signal is based on the Bell 202 standard and is superimposed on 4-20 mA Output 1. Peer-to-peer (analog / digital) and multi-drop (digital only) modes are supported.

4.1.1 Wiring

The diagrams below detail the proper connections required for HART communications:

Loop Powered Meter Wiring

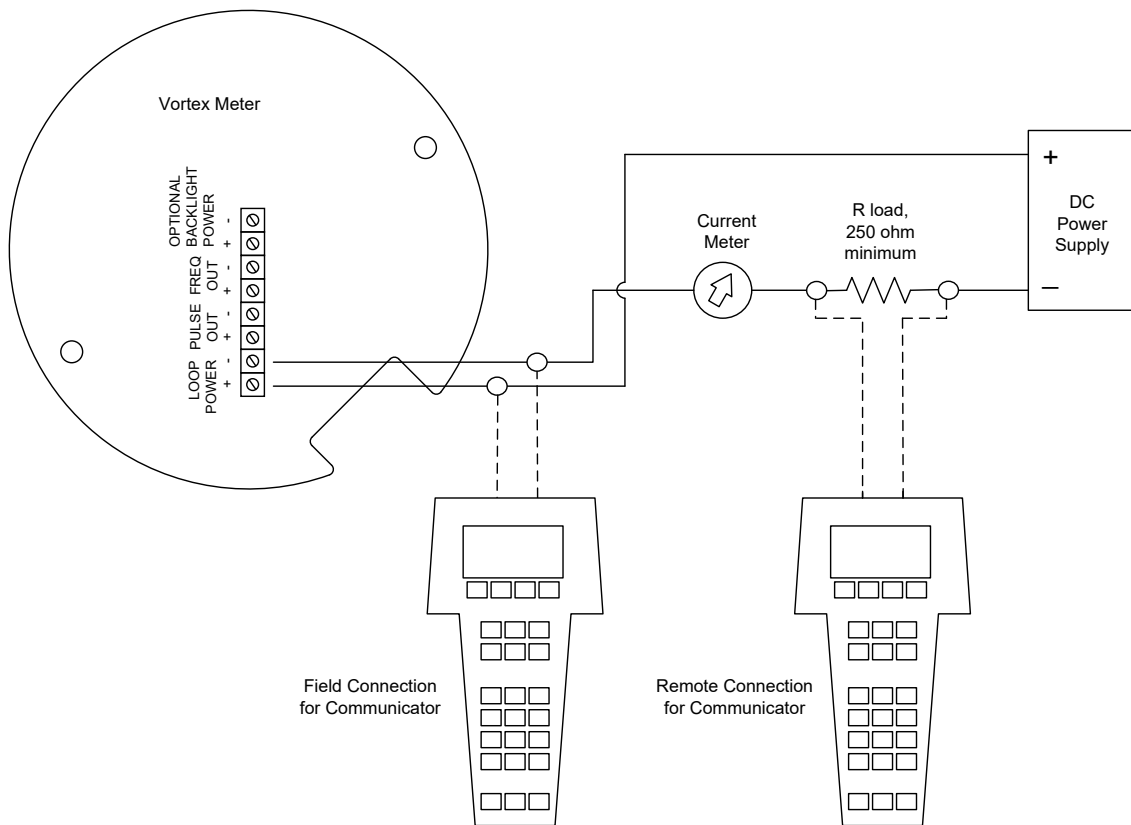

Figure 50. Loop-Powered Meter Wiring (HART)



WARNING

Place controls in manual mode when making configuration changes to the vortex meter.

DC Powered Meter Wiring

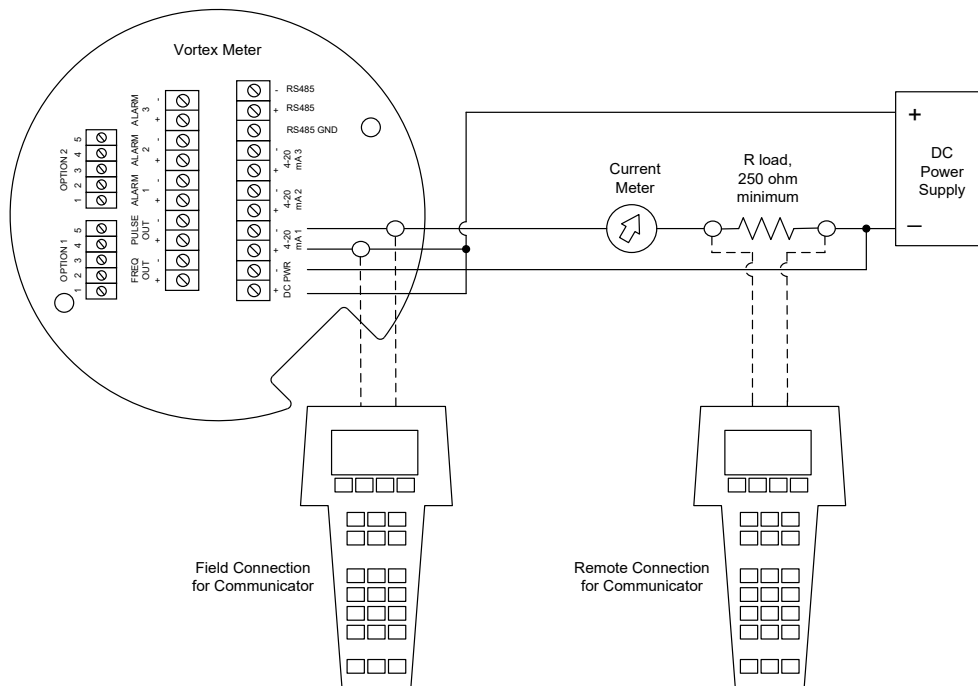

Figure 51. DC Powered Meter Wiring (HART)

AC Powered Meter Wiring

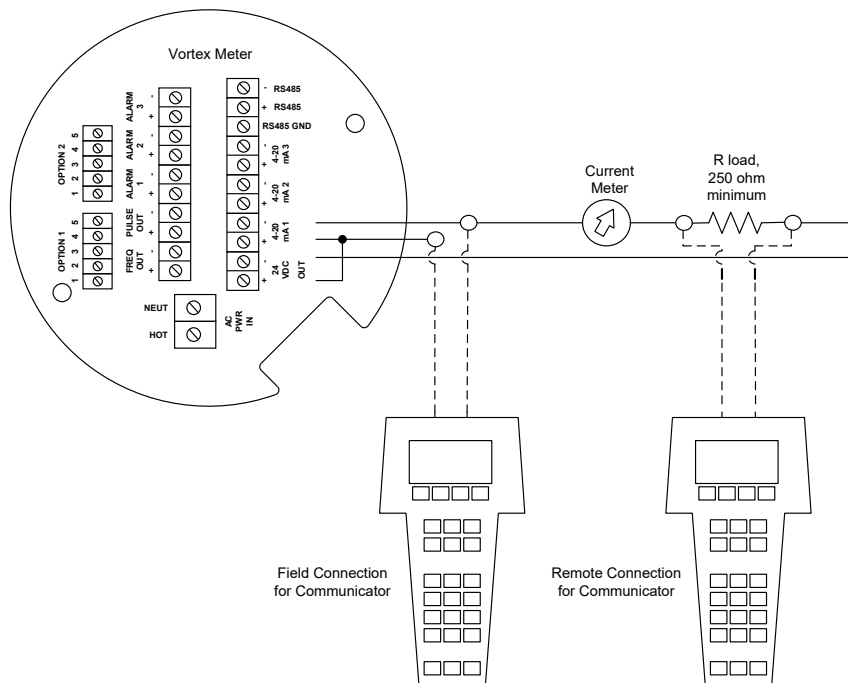
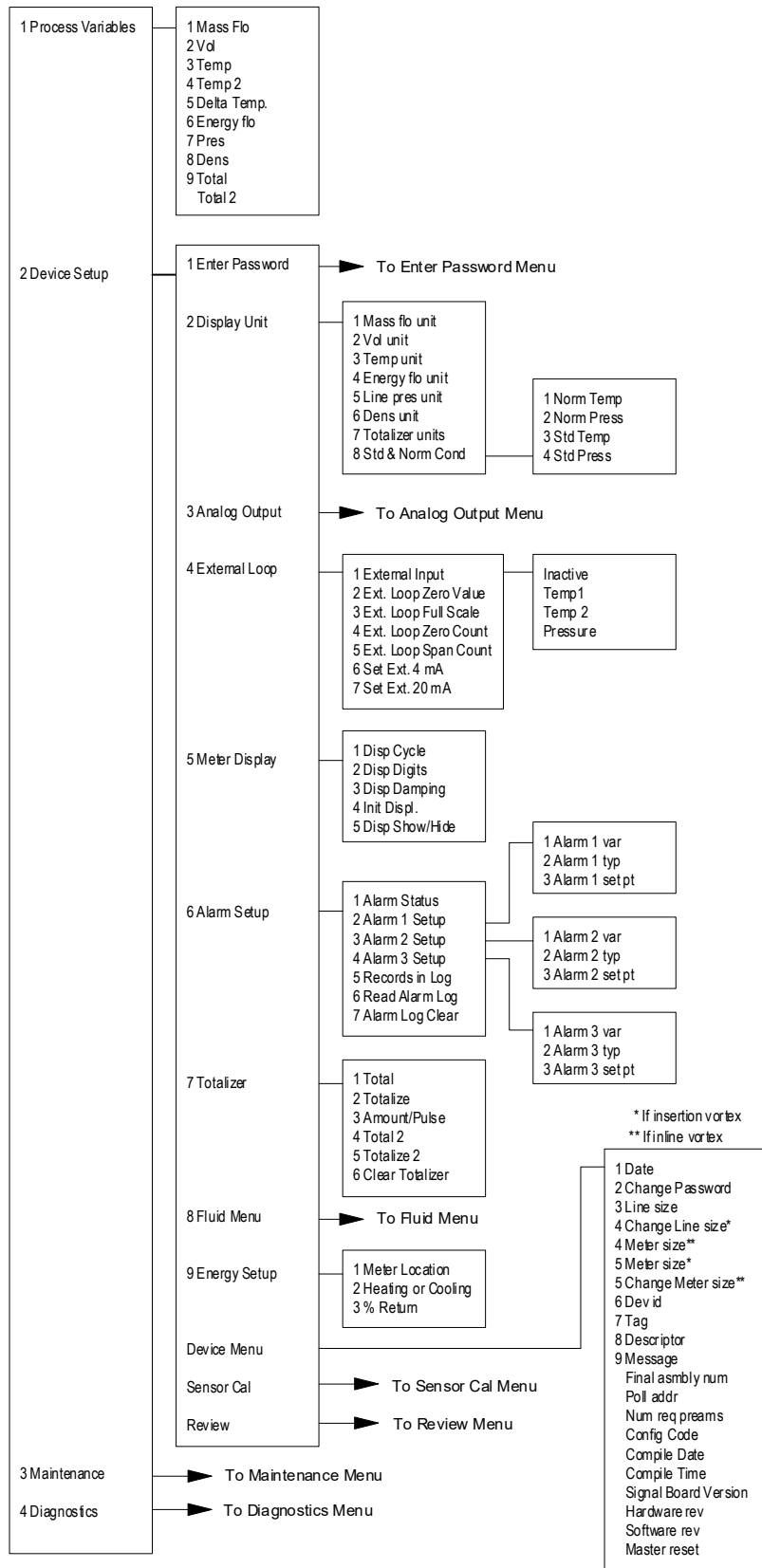

Figure 52. AC Powered Meter Wiring (HART)

4.1.2 HART Commands with the DD Menu

Online Menu



Analog Output Menu

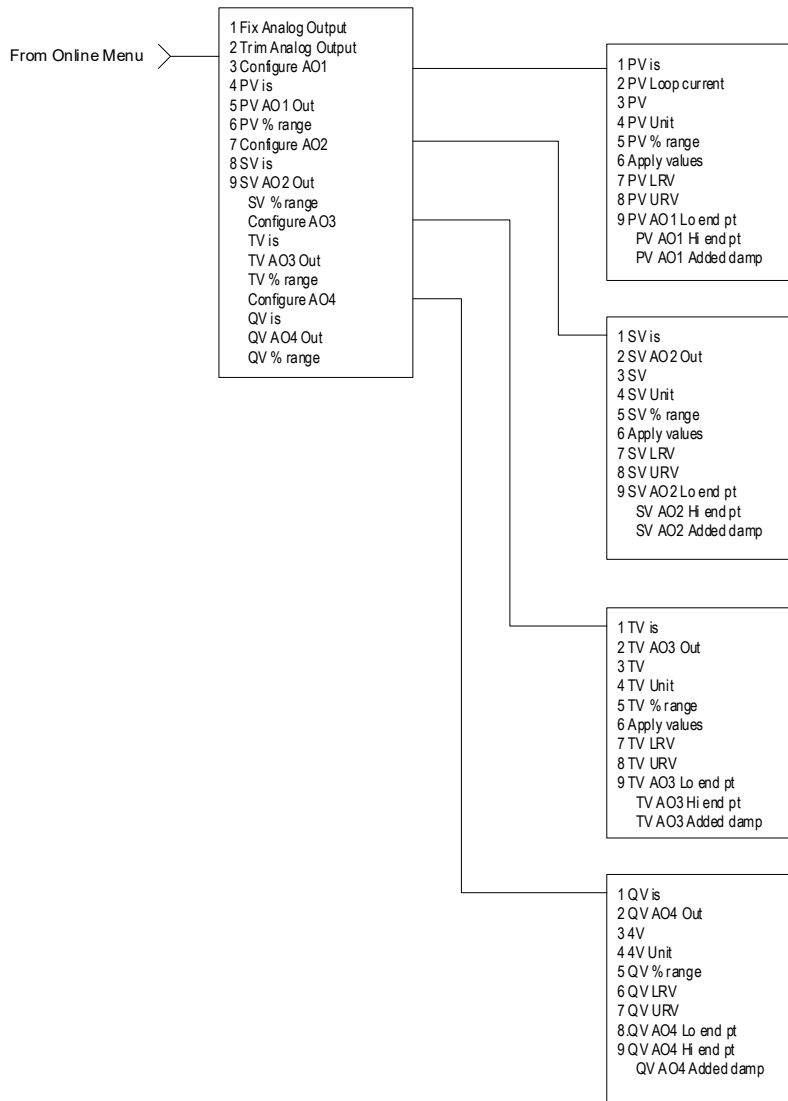

HART Commands with the DD Menu Continued

Fluid Menu

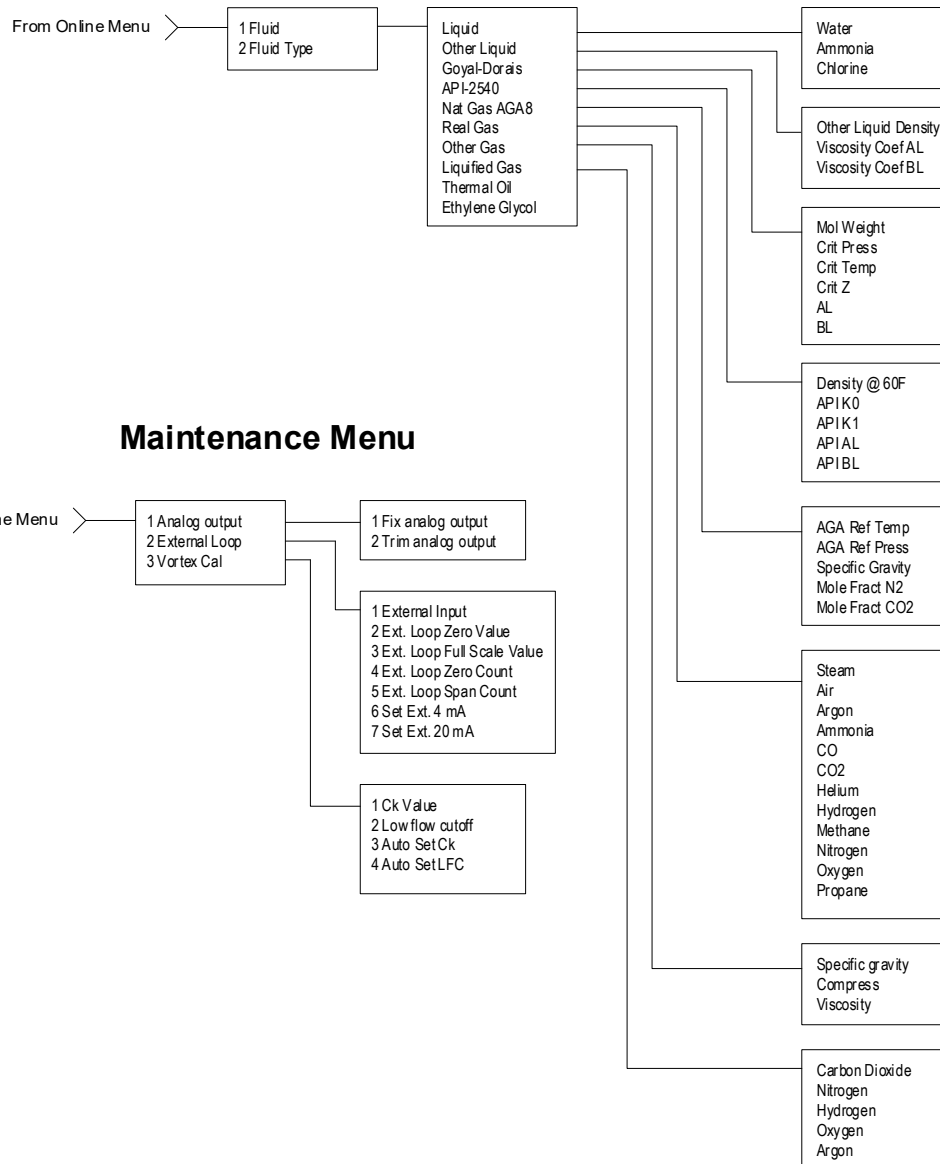

HART Commands with the DD Menu Continued

Diagnostics Menu

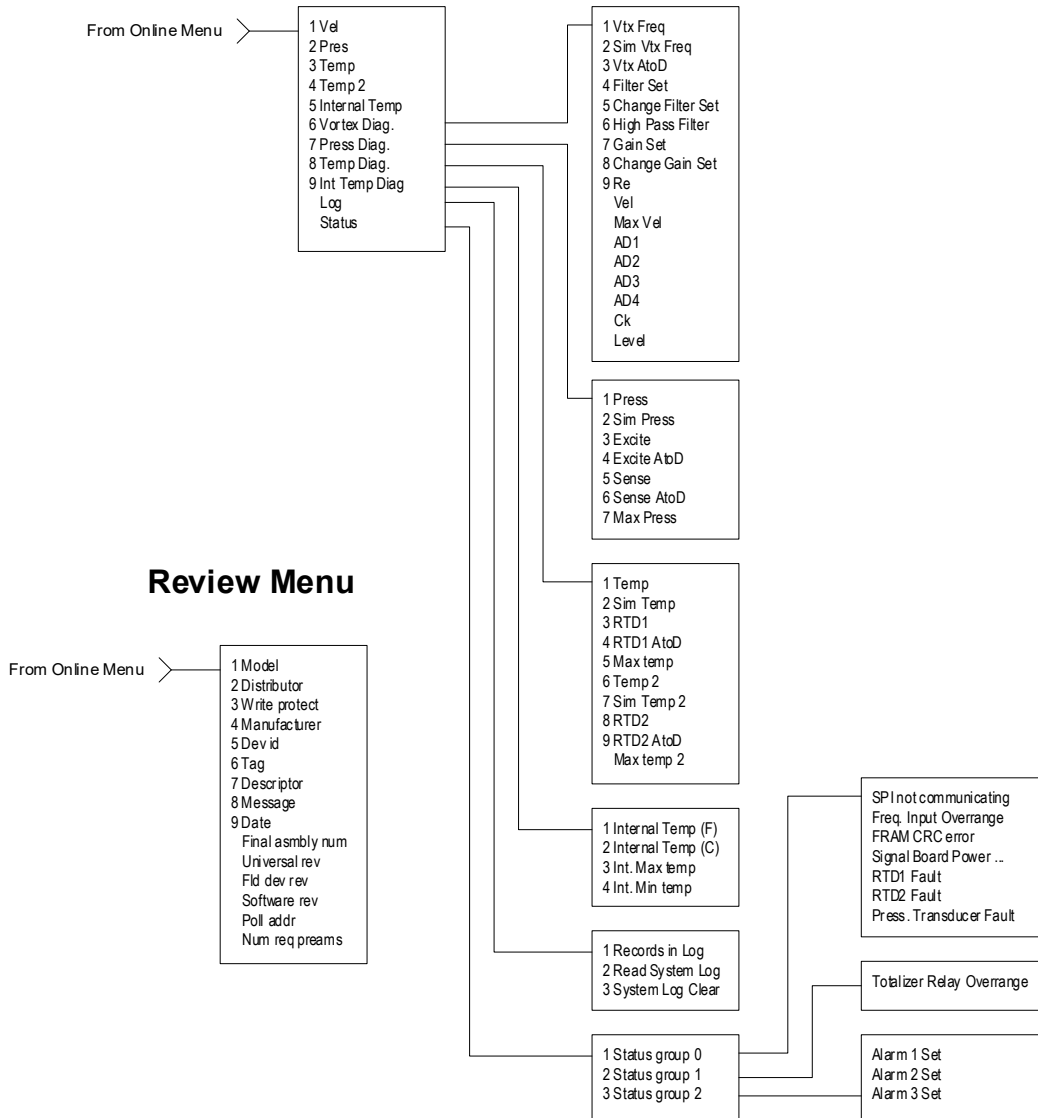

HART Commands with the DD Menu Continued

Sensor Cal Menu

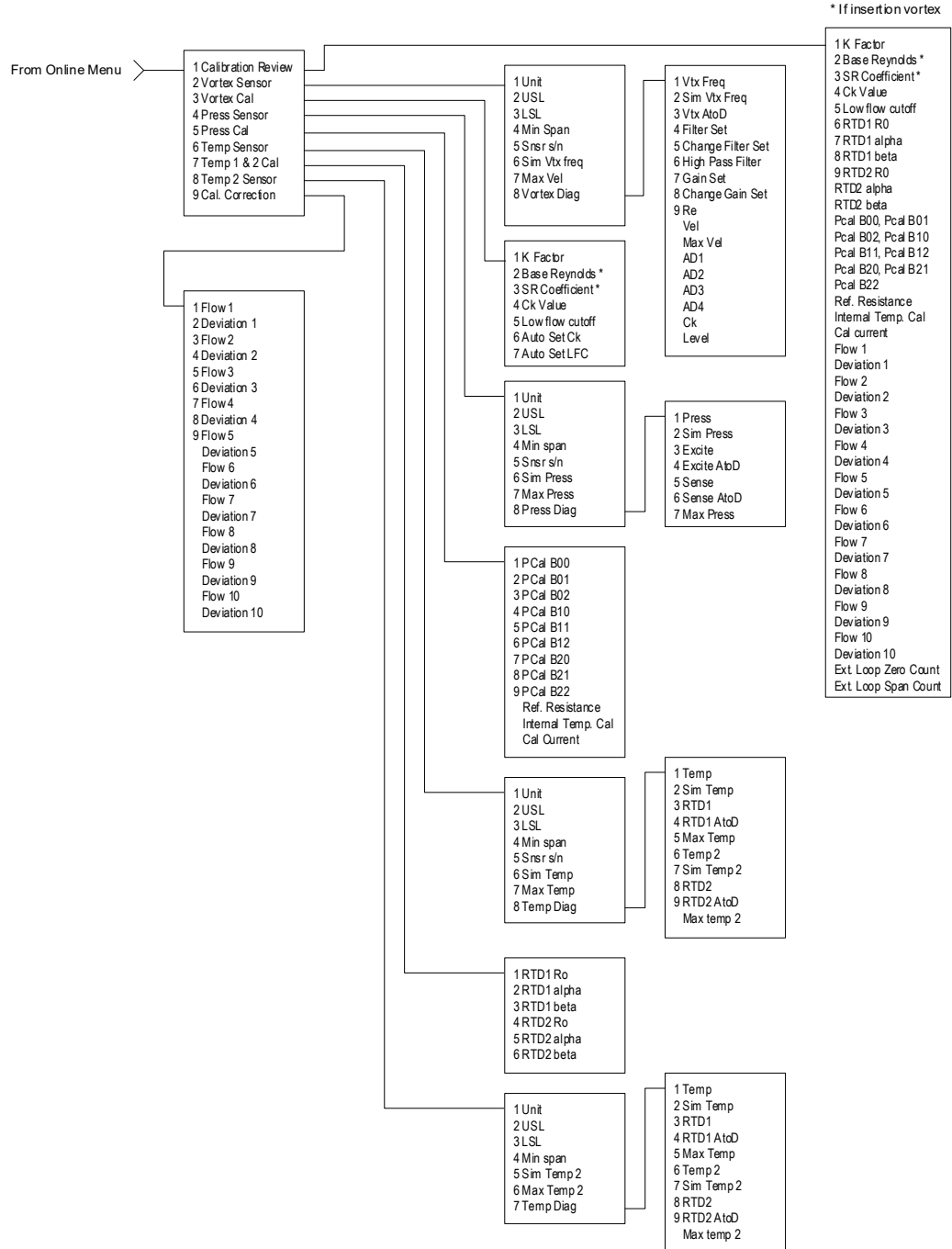

4.1.3 HART Commands with Generic DD Menu

Online Menu

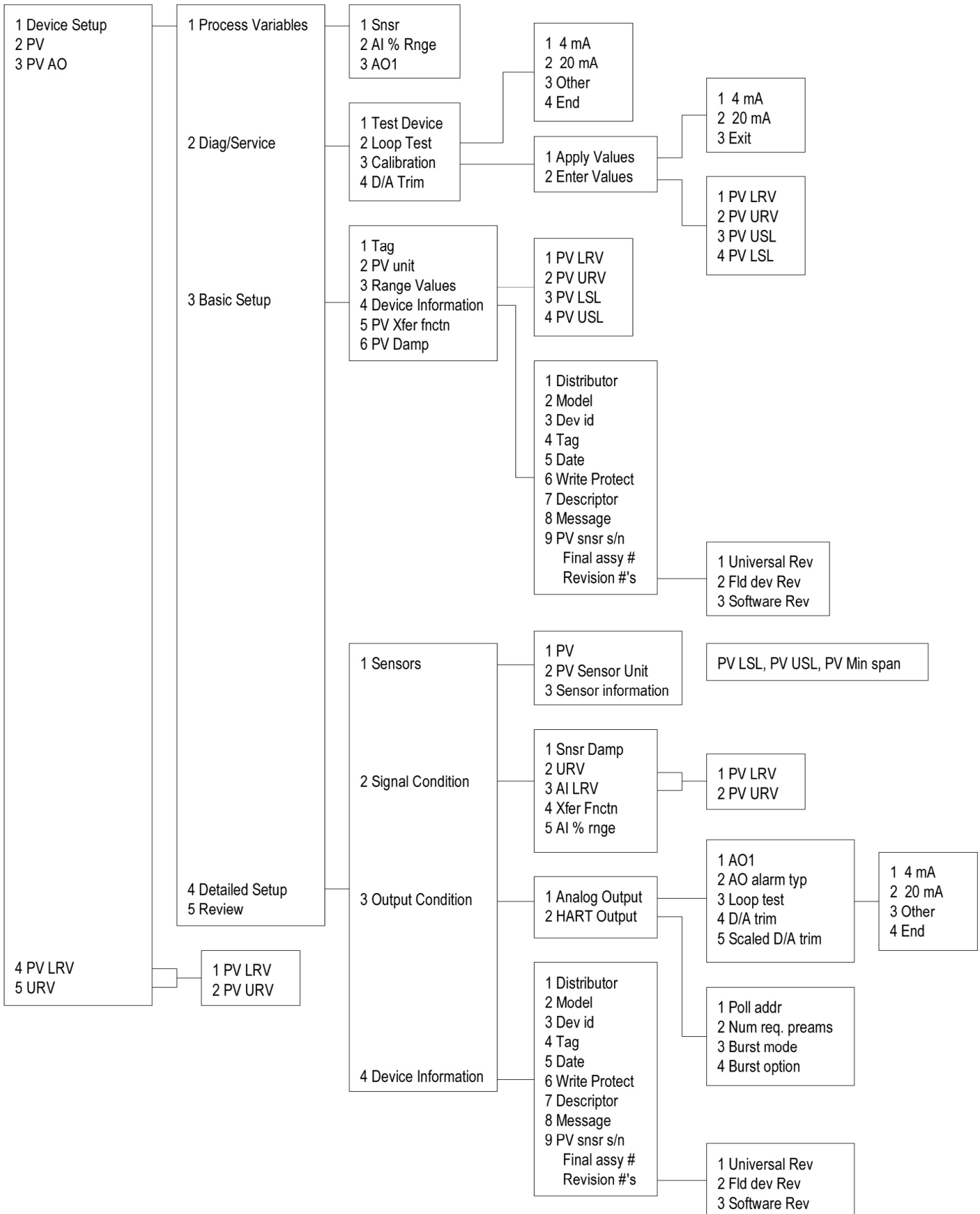

Use password 16363.

Fast Key Sequence

Use password 16363.

Sequence	Description	Access	Notes
1,1,1	Snsr	View	Primary variable value
1,1,2	AI % Rnge	View	Analog output % range
1,1,3	AO1	View	Analog output, mA
1,2,1	Test Device	N/A	Not used
1,2,2,1	4 mA	View	Loop test, fix analog output at 4 mA
1,2,2,2	20 mA	View	Loop test, fix analog output at 20 mA
1,2,2,3	Other	Edit	Loop test, fix analog output at mA value entered
1,2,2,4	End		Exit loop test
1,2,3,1,1	4 mA	N/A	Not used, apply values
1,2,3,1,2	20 mA	N/A	Not used, apply values
1,2,3,1,3	Exit		Exit apply values
1,2,3,2,1	PV LRV	Edit	Primary variable lower range value
1,2,3,2,2	PV URV	Edit	Primary variable upper range value
1,2,3,2,3	PV USL	View	Primary variable upper sensor limit
1,2,3,2,4	PV LSL	View	Primary variable lower sensor limit
1,2,4	D/A Trim	Edit	Calibrate electronics 4 mA and 20 mA values
1,3,1	Tag	Edit	Tag
1,3,2	PV unit	Edit	Primary variable units
1,3,3,1	PV LRV	Edit	Primary variable lower range value
1,3,3,2	PV URV	Edit	Primary variable upper range value
1,3,3,3	PV LSL	View	Primary variable upper sensor limit
1,3,3,4	PV USL	View	Primary variable lower sensor limit
1,3,4,1	Distributor	N/A	Not used
1,3,4,2	Model	N/A	Not used
1,3,4,3	Dev id	View	Device identification
1,3,4,4	Tag	Edit	Tag
1,3,4,5	Date	Edit	Date
1,3,4,6	Write Protect	View	Write protect
1,3,4,7	Descriptor	Edit	Vortex flowmeter
1,3,4,8	Message	Edit	32 character alphanumeric message
1,3,4,9	PV snsr s/n	View	Primary variable sensor serial number
1,3,4,menu	Final assy #	Edit	Final assembly number
1,3,4,menu,1	Universal Rev	View	Universal revision
1,3,4,menu,2	Fld dev Rev	View	Field device revision
1,3,4,menu,3	Software Rev	View	Software revision
1,3,5	PV Xfer fnctn	View	Linear
1,3,6	PV Damp	Edit	Primary variable damping (time constant) in seconds
1,4,1,1	PV	View	Primary variable value
1,4,1,2	PV Sensor Unit	Edit	Primary variable units
1,4,1,3	Sensor Information	View	PV LSL, PV USL, PV Min span

Continued on next page.

Sequence	Description	Access	Notes
1,4,2,1	Snsr Damp	Edit	Primary variable damping (time constant) in seconds
1,4,2,2,1	PV LRV	Edit	Primary variable low range value
1,4,2,2,2	PV URV	Edit	Primary variable upper range value
1,4,2,3,1	PV LRV	Edit	Primary variable low range value
1,4,2,3,2	PV URV	Edit	Primary variable upper range value
1,4,2,4	Xfer Fnctn	View	Linear
1,4,2,5	AI % rng	View	Analog output % range
1,4,3,1,1	AO1	View	Analog output, mA
1,4,3,1,2	AO alarm typ	N/A	Not used
1,4,3,1,3,1	4 mA	View	Loop test, fix analog output at 4 mA
1,4,3,1,3,2	20 mA	View	Loop test, fix analog output at 20 mA
1,4,3,1,3,3	Other	Edit	Loop test, fix analog output at mA value entered
1,4,3,1,3,4	End		Exit loop test
1,4,3,1,4	D/A trim	Edit	Calibrate electronics 4 mA and 20 mA values
1,4,3,1,5	Scaled D/A trim	N/A	Not used
1,4,3,2,1	Poll addr	Edit	Poll address
1,4,3,2,2	Num req. preams	View	Number of required preambles
1,4,3,2,3	Burst mode	N/A	Not used
1,4,3,2,4	Burst option	N/A	Not used
1,4,4,1	Distributor	N/A	Not used
1,4,4,2	Model	N/A	Not used
1,4,4,3	Dev id	View	Device identification
1,4,4,4	Tag	Edit	Tag
1,4,4,5	Date	Edit	Date
1,4,4,6	Write Protect	View	Write protect
1,4,4,7	Descriptor	Edit	Vortex flowmeter
1,4,4,8	Message	Edit	32 character alphanumeric message
1,4,4,9	PV snsr s/n	View	Primary variable sensor serial number
1,4,4,menu	Final assy #	Edit	Final assembly number
1,4,4,menu,1	Universal Rev	View	Universal revision
1,4,4,menu,2	Fld dev Rev	View	Field device revision
1,4,4,menu,3	Software Rev	View	Software revision
1,5	Review	N/A	Not used
2	PV	View	Primary variable value
3	PV AO	View	Analog output, mA
4,1	PV LRV	Edit	Primary variable lower range value
4,2	PV URV	Edit	Primary variable upper range value
5,1	PV LRV	Edit	Primary variable lower range value
5,2	PV URV	Edit	Primary variable upper range value

4.2 MODBUS COMMUNICATIONS

Applicable Flow Meter Models: ONICON F-2600 & F-2700 Series Mass Flow Meters with Modbus communication protocol and firmware version 4.00.58 and above.



WARNING

Place controls in manual mode when making configuration changes to the vortex meter.

Overview

This document describes the preliminary implementation of the Modbus communication protocol for use in monitoring common process variables in the ONICON F2600 Series Mass Vortex Flow Meter. The physical layer utilizes the half-duplex RS-485 port and the Modbus protocol.

Reference Documents

The following documents are available online from www.modbus.org.

Modbus Application Protocol Specification V1.1

Modbus Over Serial Line Specification & Implementation Guide V1.0

Modicon Modbus Protocol Reference Guide PI-MBUS-300 Rev. J

4.2.1 Wiring

An RS-485 daisy chained network configuration as depicted below is recommended. Do not use a star, ring, or cluster arrangement.

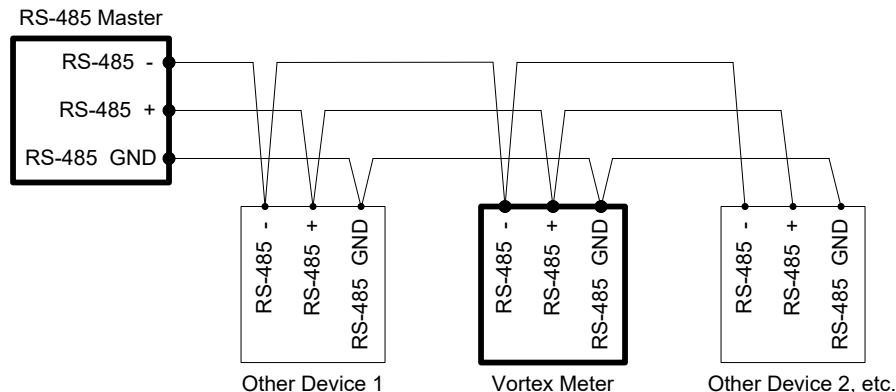

Figure 53. RS-485 Wiring (MODBUS)

PIN LABELING (AMONG DEVICES)

“RS-485 -” = “A” = “TxD-/RxD-” = “Inverting pin”

“RS-485 +” = “B” = “TxD+/RxD+” = “Non-Inverting pin”

“RS-485 GND” = “GND” = “G” = “SC” = “Reference”

4.2.2 Menu Items

The following menu items are in the Output Menu and allow selection and control of the Modbus communication protocol.

Address

When the Modbus protocol is selected, the Modbus address is equal to the user's programmable device address if it is in the range 1...247 in accordance with the Modbus specification. If the device address is zero or is greater than 247, then the Modbus address is internally set to 1.

Comm Protocol

The Comm Protocol menu allows selection of “Modbus RTU Even,” “Modbus RTU Odd,” or “Modbus RTU None2,” or “Modbus RTU None1,” (non-standard Modbus) with Even, Odd and None referring to the parity selection. When even or odd parity is selected, the unit is configured for 8 data bits, 1 parity bit and 1 stop bit; with no parity, the number of stop bits is 1 (non-standard) or 2. When changing the protocol, the change is made as soon as the Enter key is pressed.

Modbus Units

The Modbus Units menu is to control which units, where applicable, the meter's variables will be displayed in. Internal – (these are the base units of the meter, °F, psia, lbm/sec , ft3/sec, Btu/sec , lbm/ft3 Display) – variables are displayed in user selected display unit.

Modbus Order

The byte order within registers and the order in which multiple registers containing floating point or long integer data are transmitted may be changed with this menu item. According to the Modbus specification, the most significant byte of a register is transmitted first, followed by the least significant byte. The Modbus specification does not prescribe the order in which registers are transmitted when multiple registers represent values longer than 16 bits. Using this menu item, the word order and byte order for floating point and long integer values may be reversed to accommodate different Modbus operating systems.

The following four selections are available in this menu. When selecting an item, the protocol is changed immediately without having to press the ENTER key.

0-1:2-3	Most significant register first, most significant byte first (default)
2-3:0-1	Least significant register first, least significant byte first
1-0:3-2	Most significant register first, least significant byte first
3-2:1-0	Least significant register first, most significant byte first

Table 2. Byte Order

Note that all of the registers are affected by the byte order, including strings and registers representing 16-bit integers. The register order only affects the order of those registers representing 32-bit floating point and long integer data, but does not affect single 16-bit integers or strings.

Modbus Protocol

The Modbus RTU protocol is supported in this implementation. Supported baud rates are 1200, 2400, 4800, 9600, 19200, 38400, 57600, and 115200. The default baud rate is 19200 baud. Depending upon the Modbus protocol selected, data is transmitted in 8-bit data frames with even or odd parity and 1 stop bit or no parity and 2 or 1 (non-standard) stop bits.

The current Modbus protocol specification does not define register usage, but there is an informal register numbering convention derived from the original (now obsolete) Modicon Modbus protocol specification which is still used by many vendors of Modbus capable products.

Registers	Usage	Valid Function Codes
00001–09999	Read/write bits ("coils")	01 (read coils) 05 (write single coil) 15 (write multiple coils)
10001–19999	Read-only bits ("discrete inputs")	02 (read discrete inputs)
30001–39999	Read-only 16 bit registers ("input registers"), IEEE 754 floating point register pairs, arbitrary length strings encoded as two ASCII characters per 16-bit register	03 (read holding registers) 04 (read input registers)
40001–49999	Read/write 16-bit registers ("holding registers"), IEEE 754 floating point register pairs, arbitrary length strings encoded as two ASCII characters per 16-bit register	03 (read holding registers) 06 (write single register) 16 (write multiple registers)

Each range of register numbers maps to a unique range of addresses that are determined by the function code and the register number. The address is equal to the least significant four digits of the register number minus one, as shown in the following table.

Registers	Function Codes	Data Type and Address Range
00001-09999	01, 05, 15	Read/write bits 0000-9998
10001-19999	02	Read-only bits 0000-9998
30001-39999	03, 04	Read-only 16-bit registers 0000-9998
40001-49999	03, 06, 16	Read/write 16-bit registers 0000-9998

4.2.3 Register Definitions

The meter serial number and those variables that are commonly monitored (mass, volume and energy flow rates, total, pressure, temperature, density, viscosity, Reynolds number, and diagnostic variables such as frequency, velocity, gain, amplitude and filter setting) are accessible via the Modbus protocol. Long integer and floating point numbers are accessed as pairs of 16-bit registers in the register order selected in the Modbus Order menu. Floating point numbers are formatted as single precision IEEE 754 floating point values.

The flow rate, temperature, pressure, and density variables may be accessed as either the flow meter internal base units or in the user-programmed display units, which is determined by the programming Output Menu's "Modbus Units" item. The display units strings may be examined by accessing their associated registers. Each of these units string registers contain two characters of the string, and the strings may be two to 12 characters in length with unused characters set to zero. Note that the byte order affects the order in which the strings are transmitted. If the Modbus Order menu (see Section 4.2.2) is set to 0-1:2-3 or 2-3:0-1, then the characters are transmitted in the correct order. If set to 1-0:3-2 or 3-2:1-0, then each pair of characters will be transmitted in reverse order.

Registers	Variable	Data Type	Units	Function Code	Addresses
65100-65101	Serial number	unsigned long	—	03, 04	
30525-30526	Totalizer	unsigned long	display units	03, 04	524-525
32037-32042	Totalizer units	string	—	03, 04	2036-2041
30009-30010	Mass flow	float	display units	03, 04	8-9
30007-30008	Volume flow	float	display units	03, 04	6-7
30005-30006	Pressure	float	display units	03, 04	4-5
30001-30002	Temperature	float	display units	03, 04	0-1
30029-30030	Velocity	float	ft/sec	03, 04	28-29
30015-30016	Density	float	display units	03, 04	14-15
30013-30014	Viscosity	float	cP	03, 04	12-13
30031-30032	Reynolds number	float	—	03, 04	30-31
30025-30026	Vortex frequency	float	Hz	03, 04	24-25
34532	Gain	char	—	03, 04	4531
30085-30086	Vortex amplitude	float	Vrms	03, 04	84-85
30027-30028	Filter setting	float	Hz	03, 04	26-27

Table 3. Register Definitions

The following registers are available with the energy meter firmware:

Registers	Variable	Data Type	Units	Function Code	Addresses
30527-30528	Totalizer #2	unsigned long	display units	03, 04	526-527
32043-32048	Totalizer #2 units	string	—	03, 04	2042-2047
30003-30004	Temperature #2	float	display units	03, 04	2-3
30011-30012	Energy flow	float	display units	03, 04	10-11

The following registers contain the display units strings:

Registers	Variable	Data Type	Units	Function Code	Addresses
32007-32012	Volume flow units	string	—	03, 04	2006-2011
32001-32006	Mass flow units	string	—	03, 04	2000-2005
32025-32030	Temperature units	string	—	03, 04	2024-2029
32019-32024	Pressure units	string	—	03, 04	2018-2023
32031-32036	Density units	string	—	03, 04	2030-2035
32013-32017	Energy flow units	string	—	03, 04	2012-2017

Function codes 03 (read holding registers) and 04 (read input registers) are the only codes supported for reading these registers, and function codes for writing holding registers are not implemented. We recommend that the floating point and long integer registers be read in a single operation with the number of registers being a multiple of two. If this data is read in two separate operations, each reading a single 16-bit register, then the value will likely be invalid.

The floating point registers with values in display units are scaled to the same units as are displayed, but are instantaneous values that are not smoothed. If display smoothing is enabled (non-zero value entered in the Display TC item in the Display Menu), then the register values will not agree exactly with the displayed values.

Exception Status Definitions

The Read Exception Status command (function code 07) returns the exception status byte, which is defined as follows. This byte may be cleared by setting “coil” register #00003 (function code 5, address 2, data = 0xff00).

Bit(s)	Definition
0-1	Byte order (see Modbus Order on page 2) 0 = 3-2:1-0 1 = 2-3:0-1 2 = 1-0:3-2 3 = 0-1:2-3
2	Temperature sensor fault
3	Pressure sensor fault
4	A/D converter fault
5	Period overflow
6	Pulse overflow
7	Configuration changed

Discrete Input Definitions

The status of the three alarms may be monitored via the Modbus Read Discrete Input command (function code 02). The value returned indicates the state of the alarm, and will be #1 only if the alarm is enabled and active. A zero value is transmitted for alarms that are either disabled or inactive.

Registers	Variable	Function Code	Address
10001	Alarm #1 state	02	0
10002	Alarm #2 state	02	1
10003	Alarm #3 state	02	2

Control Register Definitions

The only writable registers in this implementation are the Reset Exception Status, Reset Meter and Reset Totalizer functions, which are implemented as "coils" which may be written with the Write Single Coil command (function code 05) to address 8 through 10, respectively (register #00009 through #00011). The value sent with this command must be either 0x0000 or 0xff00, or the meter will respond with an error message. The totalizer will be reset or exception status cleared only with a value of 0xff00.

Error Responses

If an error is detected in the message received by the unit, the function code in the response is the received function code with the most significant bit set, and the data field will contain the exception code byte as follows:

Exception Code	Description
01	Invalid function code — function code not supported by device
02	Invalid data address — address defined by the start address and number of registers is out of range
03	Invalid data value — number of registers = 0 or >125 or incorrect data with the Write Single Coil command

If the first byte of a message is not equal to the unit's Modbus address, if the unit detects a parity error in any character in the received message (with even or odd parity enabled), or if the message CRC is incorrect, the unit will not respond.

Command Message Format

The start address is equal to the desired first register number minus one. The addresses derived from the start address and the number of registers must all be mapped to valid defined registers, or an invalid data address exception will occur.

Device Address	Function Code	Start Address	N=Number of Registers	CRC
8 bits, 1...247	8 bits	16 bits, 0...9998	16 bits, 1...125	16 bits

Normal Response Message Format

Device Address	Function Code	Byte Count = 2	Data	CRC
8 bits, 1...247	8 bits	x N	(N) 16-bit registers	16 bits

Exception Response Message Format

Device Address	Function Code	Exception Code	CRC
8 bits, 1...247	8 bits	8 bits	16 bits

Examples

Read the exception status byte from the device with address 1:

01 07 41 E2

01 Device address
07 Function code, 04 = read exception status

A typical response from the device is as follows:

01 07 03 62 31

01 Device address
07 Function code
03 Exception status byte
62 31 CRC

Request the first 12 registers from device with address 1:

01 04 00 00 00 0C F0 0F

01 Device address
04 Function code, 04 = read input register
00 00 Starting address
00 0C Number of registers = 12
F0 0F CRC

A typical response from the device is as follows: *Note these are the older register definitions.

01 04 18 00 00 03 E8 00 00 7A 02 6C 62 00 00 41 BA 87 F2 3E BF FC 6F 42 12
EC 8B 4D D1

01 Device address
04 Function code
18 Number of data bytes = 24
00 00 03 E8 Serial number = 1000 (unsigned long)
00 00 7A 02 Totalizer = 31234 lbm (unsigned long)
6C 62 00 00 Totalizer units = "lb" (string, unused characters are 0)
41 BA 87 F2 Mass flow rate = 23.3164 lbm/sec (float)
3E BF FC 6F Volume flow rate = 0.3750 ft³/sec (float)
42 12 EC 8B Pressure = 36.731 psia (float)
4D D1 CRC

An attempt to read register(s) that don't exist:

01 04 00 00 00 50 F1 D2

01 Device address
04 Function code 4 = read input register
00 00 Starting address
00 50 Number of registers = 80
F0 36 CRC

Results in an error response as follows:

01 84 02 C2 C1

01 Device address
84 Function code with most significant bit set indicates error response
02 Exception code 2 = invalid data address
C2 C1 CRC

Request the state all three alarms:

01 02 00 00 00 03 38 0B

01 Device address
02 Function code 2 = read discrete inputs
00 00 Starting address
00 03 Number of inputs = 3
38 0B CRC

And the unit responds with:

01 02 01 02 20 49

01 Device address
02 Function code
01 Number of data bytes = 1
02 Alarm #2 on, alarms #1 and #3 off
20 49 CRC

To reset the totalizer:

01 05 00 00 FF 00 8C 3A

01 Device address
05 Function code 5 = write single coil
00 09 Coil address = 9
FF 00 Data to reset totalizer
8C 3A CRC (not the correct CRC EJS-02-06-07)

The unit responds with an identical message to that transmitted, and the totalizer is reset. If the “coil” is turned off as in the following message, the response is also identical to the transmitted message, but the totalizer is not affected.

01 05 00 00 00 00 CD CA

01 Device address
05 Function code 5 = write single coil
00 00 Coil address = 0
00 00 Data to “turn off coil” does not reset totalizer
CD CA CRC

4.3 BACnet MS/TP Communications

4.3.1. BACnet MS/TP Description

The BACnet Master-Slave/Token-Passing (MSTP) driver implements a data link protocol that uses the services of the RS-485 physical layer. The MS/TP bus is based on BACnet standard protocol SSPC-135, Clause 9. BACnet MS/TP protocol is a peer-to-peer, multiple master protocols based on token passing. Only master devices can receive the token, and only the device holding the token is allowed to originate a message on the bus. The token is passed from master device to master device using a small message. The token is passed in consecutive order starting with the lowest address. Slave devices on the bus only communicate on the bus when responding to a data request from a master device.

4.3.2. Baud Rates on the MS/TP Bus

An MS/TP bus can be configured to communicate at one of four different baud rates. It is very important that all of the devices on an MS/TP bus communicate at the same baud rate. The baud rate setting determines the rate at which devices communicate data over the bus. The available baud rate settings available on F-2600 and F-2700 Flow Meters are 9600, 19200, 38400 and 76800.

4.3.2.1. Baud Rate and MAC address configuration

1. Power on the meter
2. Press Enter to go configuration menu
3. Give the factory password 16363 (Use Up and Down arrows to enter the digits)
4. Navigate to Diagnostics menus using the left arrow
5. Press Enter and press right button immediately
6. Navigate to Config Code screen by continuous pressing down button
7. After reaching config code screen, press right to navigate to Comm. Type screen
8. Change the comm. Type to “BACnet” and press Enter
Note: Modbus will enable Baud Rate and MAC address screens
9. Press Exit twice to reach Diagnostics menu back
10. Navigate to Output Menu by using right or left arrow buttons
11. Press Down button and reach Baud Rate and MAC address screens
12. Change the required settings and press Exit & Enter buttons to save the configuration
13. Reboot the device by power off and on.

Note:

- a. Baud rates are 9600, 19200, 38400 or 76800
- b. MAC address range is 0-127

4.3.3. Supported BACnet Objects

A BACnet object represents physical or virtual equipment information, as a digital input or parameters. ONICON F-2600 and F-2700 Flow Meters present the following object types:

- A. Device Object
- B. Analog Input
- C. Binary Input
- D. Binary Value

Each object type defines a data structure composed by properties that allow the access to the object information. The below table shows the implemented properties for each Vortex Mass Flow Meters object type.

Properties	Object Type			
	Device	Analog Input	Binary Input	Binary Value
Object_Identifier	<input checked="" type="checkbox"/>	<input checked="" type="checkbox"/>	<input checked="" type="checkbox"/>	<input checked="" type="checkbox"/>
Object_Name	<input checked="" type="checkbox"/>	<input checked="" type="checkbox"/>	<input checked="" type="checkbox"/>	<input checked="" type="checkbox"/>
Object_Type	<input checked="" type="checkbox"/>	<input checked="" type="checkbox"/>	<input checked="" type="checkbox"/>	<input checked="" type="checkbox"/>
System_Status	<input checked="" type="checkbox"/>			
Vendor_Name	<input checked="" type="checkbox"/>			
Vendor_Identifier	<input checked="" type="checkbox"/>			
Model_Name	<input checked="" type="checkbox"/>			
Firmware_Revision	<input checked="" type="checkbox"/>			
Application-Software-Version	<input checked="" type="checkbox"/>			
Protocol_Version	<input checked="" type="checkbox"/>			
Protocol_Revision	<input checked="" type="checkbox"/>			
Protocol_Services_Supported	<input checked="" type="checkbox"/>			
Protocol_Object_Types_Supported	<input checked="" type="checkbox"/>			
Object_List	<input checked="" type="checkbox"/>			
Max_ADPU_Length_Accepted	<input checked="" type="checkbox"/>			
Segmentation_Supported	<input checked="" type="checkbox"/>			
ADPU_Timeout	<input checked="" type="checkbox"/>			
Number_Of_ADPU_Retries	<input checked="" type="checkbox"/>			
Max_Masters	<input checked="" type="checkbox"/>			
Max_Info_Frames	<input checked="" type="checkbox"/>			
Device_Address_Binding	<input checked="" type="checkbox"/>			
Database_Revision	<input checked="" type="checkbox"/>			
Status_Flags				
Event_State		<input checked="" type="checkbox"/>	<input checked="" type="checkbox"/>	<input checked="" type="checkbox"/>
Reliability				
Out_Of_Service		<input checked="" type="checkbox"/> (W)	<input checked="" type="checkbox"/> (W)	<input checked="" type="checkbox"/> (W)
Units				
Polarity			<input checked="" type="checkbox"/> (W)	
Priority_Array				
Relinquish_Default				
Status_Flag		<input checked="" type="checkbox"/>	<input checked="" type="checkbox"/>	<input checked="" type="checkbox"/>
Present_Value		<input checked="" type="checkbox"/> (W)	<input checked="" type="checkbox"/> (W)	<input checked="" type="checkbox"/> (W)
Inactive_Text				
Active_Text				

(W) – Writable Property.

4.3.3.1. Device Object:

The Device object default property values are as follows –

Property Name	Default Values
object-identifier	7
object-name	Device,1
object-type	Device
system-status	operational
vendor-name	ONICON, Incorporated
vendor-identifier	206
model-name	Vortex Meter
firmware-revision	N/A
application-softwareversion	1.07
protocol-version	1
protocol-revision	4
protocol-servicesupported	{F,F,F,F,F,F,F,F,F,F,F,T,T,T,T,T,F,F,F,F,F,F,F,F,F,T,T,F,F,F,F}
protocol-object-types-supported	{T,F,F,T,F,T,F,T,F,F,F,F,F,F,F,F,F,F,F,F,F}
object-list	{(analog-input,1), (analog-input,2), (analog-input,3), (analog-input,4), (analog-input,5), (analog-input,6), (analog-input,7), (analog-input,8), (analog-input,9), (analog-input,10), (analog-input,11), (analoginput,12), (analog-input,13), (analog-input,14), (analoginput,15), (analog-input,16), (analog-input,17), (analoginput,18), (analog-input,19), (binary-input,1), (binary-input,2), (binaryinput,3), (binary-input,4), (binary-value,1), (device,7) }
max-apdu-lengthaccepted	300
segmentation-supported	no-segmentation
apdu-timeout	3000
number-of-APDU-retries	1
max-master	127
max-info-frames	1
device-address-binding	()
database-revision	0

Note - Device Communication Control: Password – “vortek”

4.3.3.2. Analog Input Object:

Vortex Mass Flow Meters Analog Input type objects are described in the below Table –

Object Instance	Object Name	Unit	Description
1	Volume Flow	cubic-foot-per-second, cubic-foot-per-minute, us-gallons-per-minute, imperial-gallons-perminute, liters-per-minute, liters-per-second, liters-per-hour, cubic-meters-per-second, cubic-meters-per-minute, cubic-meters-per-hour	This AI object is used to measure volume flow.

2	Mass Flow	pounds-mass-per-second, grams-per-second, kilograms-per-second, kilograms-per-minute, kilograms-per-hour, pounds-mass-per-minute, pounds-mass-per-hour, tons-per-hour, grams-per-second , grams-per-minute	This AI object is used to measure mass flow.
3	Temperature 1	degrees-Celsius, degrees-Kelvin, degrees-Fahrenheit	This AI object measures Temperature in one of the given Unit.
4	Temperature 2	degrees-Celsius, degrees-Kelvin, degrees-Fahrenheit	This AI object measures Temperature in one of the given Unit.
5	Pressure	pounds-force-per-squareinch, inches-of-water, inches-of-mercury, millimeters-of-mercury, bars, millibars, pascals, kilopascals	TBD
6	Density	kilograms-per-cubic-meter	TBD
7	Energy Flow	Kilowatts, Horsepower, btus-per-hour, kilo-btus-per-hour, megawatts	TBD
8	Totalizer 1 & Totalizer 2	If Totalizer selection for Mass measure – pounds-mass-per-second, grams-per-second, kilograms-per-second, kilograms-per-minute, kilograms-per-hour, pounds-mass-per-minute, pounds-mass-per-hour, tons-per-hour, grams-per-second, grams-per-minute If Totalizer selection for Volume measure – cubic-feet-per-second, cubic-feet-per-minute, us-gallons-per-minute, imperial-gallons-per-minute, liters-per-minute, liters-per-second, liters-per-hour, cubic-meters-per-second, cubic-meters-per-minute, cubic-meters-per-hour If Totalizer selection for Energy measure – Kilowatts, Horsepower, btus-per-hour, kilo-btus-per-hour, megawatts	An electronic counter which records the total accumulated flow over a certain range of time.
10	StatusRegister	NO UNITS	TBD
11	Channel 1 (4-20mA)	milliamperes	TBD
12	Channel 2 (4-20mA)	milliamperes	TBD
13	Channel 3 (4-20mA)	milliamperes	TBD
14	Scaled Freq	hertz	TBD
15	Flow Velocity	feet-per-second	TBD
16	Viscosity	centipoises	TBD
17	Frequency	hertz	TBD
18	VorTex Amp	millivolts	TBD
19	FilterSetting	hertz	TBD

4.3.3.3. Binary Input Object:

Vortex Mass Flow Meters Binary Input type objects are described in the below Table.

Object Instance	Object Name	Description
1	Alarm1	The status of the three alarms may be monitored via the Modbus command. The value returned indicates the state of the alarm, and will be 1 only if the alarm is enabled and active. A zero value is transmitted for alarms that are either disabled or inactive
2	Alarm2	
3	Alarm3	
4	External	TBD

Note - Binary Input 4, Present value always read zero, because no information available from client, so the polarity property doesn't impact on Present value property when the Out of service property is false.

3.4. Binary Value Object:

Vortex Mass Flow Meters Binary Value type objects are described in the below Table.

Object Instance	Object Name	Description
1	Reset	Reset's Totalizer

4.3.4. ANNEX - BACnet PROTOCOL IMPLEMENTATION CONFORMANCE STATEMENT

Date: 19-April-2012

Vendor Name: ONICON Incorporated

Product Name: F-2000 Series Vortex Meter

Product Model Number: F-2600 / F-2700

Applications Software Version: 1.07

Firmware Revision: N/A

BACnet Protocol Revision: 4

Product Description: Multivariable Vortex Flow Meter

BACnet Standardized Device Profile (Annex L):

BACnet Operator Workstation (B-OWS)

BACnet Advanced Operator Workstation (B-AWS)

BACnet Operator Display (B-OD)

BACnet Building Controller (B-BC)

BACnet Advanced Application Controller (B-AAC)

BACnet Application Specific Controller (B-ASC)

BACnet Smart Sensor (B-SS)

BACnet Smart Actuator (B-SA)

List all BACnet Interoperability Building Blocks Supported (Annex K):

BIBBs
DS-RP-B
DS-WP-B
DM-DDB-B
DM-DOB-B
DM-DCC-B
DS-RPM-B
DS-WPM-B

Services Supported	
Read Property	Execute
Write Property	Execute
Read Property Multiple	Execute
Write Property Multiple	Execute
Who-Is	Execute
I-AM	Initiate
Who-Has	Execute
I-Have	Initiate
Device Communication Control	Execute

Segmentation Capability:

Able to transmit segmented messages No
 Able to receive segmented messages No

Standard Object Types Supported:

Standard Object Types Supported				
Object Type	Dynamically Creatable	Dynamically Delete-able	Additional Writable Properties	Range Restrictions
Analog Input (AI)	No	No	None	None
Binary Input (BV)	No	No	None	None
Binary Value	No	No	None	None
Device	No	No	None	None

Standard Object Types Supported Writable Properties			
Object Type	Properties		
Analog Input (AI)	Present Value	Out-Of-Service	
Binary Input (BV)	Present Value	Out-Of-Service	Polarity
Binary Value	Present Value	Out-Of-Service	
Device			

Properties of Analog Input/Value Objects Type						
ID	Name	Present Value	Status Flags	Event State	Out of Service	Units
AI1	Volume Flow	?	F,F,F,F	Normal	False	?
AI2	Mass Flow	?	F,F,F,F	Normal	False	?
AI3	Temperature 1	?	F,F,F,F	Normal	False	?
AI4	Temperature 2	?	F,F,F,F	Normal	False	?
AI5	Pressure	?	F,F,F,F	Normal	False	?
AI6	Density	?	F,F,F,F	Normal	False	?
AI7	Energy Flow	?	F,F,F,F	Normal	False	?
AI8	Totalizer 1	?	F,F,F,F	Normal	False	?
AI9	Totalizer 2	?	F,F,F,F	Normal	False	?
AI10	StatusRegister	?	F,F,F,F	Normal	False	?
AI11	Channel 1 (4-20mA)	?	F,F,F,F	Normal	False	?
AI12	Channel 2 (4-20mA)	?	F,F,F,F	Normal	False	?
AI13	Channel 3 (4-20mA)	?	F,F,F,F	Normal	False	?
AI14	Scaled Freq	?	F,F,F,F	Normal	False	?
AI15	Flow Velocity	?	F,F,F,F	Normal	False	?
AI16	Viscosity	?	F,F,F,F	Normal	False	?
AI17	Frequency	?	F,F,F,F	Normal	False	?
AI18	VorTex Amp	?	F,F,F,F	Normal	False	?
AI19	FilterSetting	?	F,F,F,F	Normal	False	?

Properties of Analog Input/Value Objects Type						
ID	Name	Present Value	Status Flags	Event State	Out of Service	Polarity
BI1	Alarm1	?	F,F,F,F	Normal	False	?
BI2	Alarm2	?	F,F,F,F	Normal	False	?
BI3	Alarm3	?	F,F,F,F	Normal	False	?
BI4	External	?	F,F,F,F	Normal	False	?

Properties of Analog Input/Value Objects Type						
ID	Name	Present Value	Status Flags	Event State	Out of Service	Out-of-Service
BV1	Reset	?	F,F,F,F	Normal	False	False

Data Link Layer Options:

- BACnet IP, (Annex J)
- BACnet IP, (Annex J), Foreign Device
- ISO 8802-3, Ethernet (Clause 7)
- ANSI/ATA 878.1, 2.5 Mb. ARCNET (Clause 8)
- ANSI/ATA 878.1, EIA-485 ARCNET (Clause 8), baud rate(s)
- √ MS/TP master (Clause 9), baud rate(s): 9600, 19200, 38400, 76800
- MS/TP slave (Clause 9), baud rate(s):
- Point-To-Point, EIA 232 (Clause 10), baud rate(s):
- Point-To-Point, modem, (Clause 10), baud rate(s):
- LonTalk, (Clause 11), medium:
- Other:

Device Address Binding:

Is static device binding supported? (This is currently necessary for two-way communication with MS/TP slaves and certain other devices.) :

Yes No

Networking Options:

Router, Clause 6 - List all routing configurations, e.g., ARCNET/Ethernet, Ethernet-MS/TP, etc.

Annex H, BACnet Tunneling Router over IP

BACnet/IP Broadcast Management Device (BBMD)

Does the BBMD support registrations by Foreign Devices?

Yes No

Does the BBMD support network address translation?

Yes No

Network Security Options:

Non-secure Device - is capable of operating without BACnet Network Security

Secure Device - is capable of using BACnet Network Security (NS-SD BVBB)

Multiple Application-Specific Keys:

Supports encryption (NS-ED BVBB)

Key Server (NS-KS BVBB)

Character Sets Supported:

Indicating support for multiple character sets does not imply that they can all be supported simultaneously.

ANSI X3.4

IBM™/Microsoft™DBCS

ISO 8859-1

ISO 10646 (UCS-2)

ISO 10646 (UCS-4)

JIS C 6226

If this product is a communication gateway, describe the types of non-BACnet equipment/networks(s) that the gateway supports:

- N/A

4.3.5. Acronyms and Definitions

Item	Description
APDU	Application Protocol Data Unit
BACnet	Building Automation and Control Network - Data communication protocol
MS/TP	Master-Slave Token passing (a twisted pair RS485 network created by BACnet)
BIBB	BACnet Interoperability Building Block (Specific individual function blocks for data exchange between interoperable devices).
BV	Binary Value
BI	Binary Input
AI	Analog Input
RP	Read Property
WP	Write Property
RPM	Read Property Multiple
WPM	Write Property Multiple
DDB	Dynamic Device Binding
DOB	Dynamic Object Binding
DCC	Device communication Control

SECTION 5.0: TROUBLESHOOTING AND REPAIR

5.1 HIDDEN DIAGNOSTICS MENUS

The menus shown on the following page can be accessed using the password 16363, then moving to the display that reads “Diagnostics Menu” and pressing ENTER (rather than one of the arrow keys).

Use the right arrow key to move to the second level. Press EXIT to move from the second level back to the first. Press EXIT while in the first level to return to the set-up menus.



CAUTION

Password 16363 will allow full access to the configuration and should be used carefully to avoid changes that can adversely alter the function of the meter.

Each of the menus on the following page will first be defined followed by specific troubleshooting steps.



WARNING

Before attempting any flow meter repair, verify that the line is not pressurized. Always remove main power before disassembling any part of the mass flow meter.

Hidden Diagnostics Menus

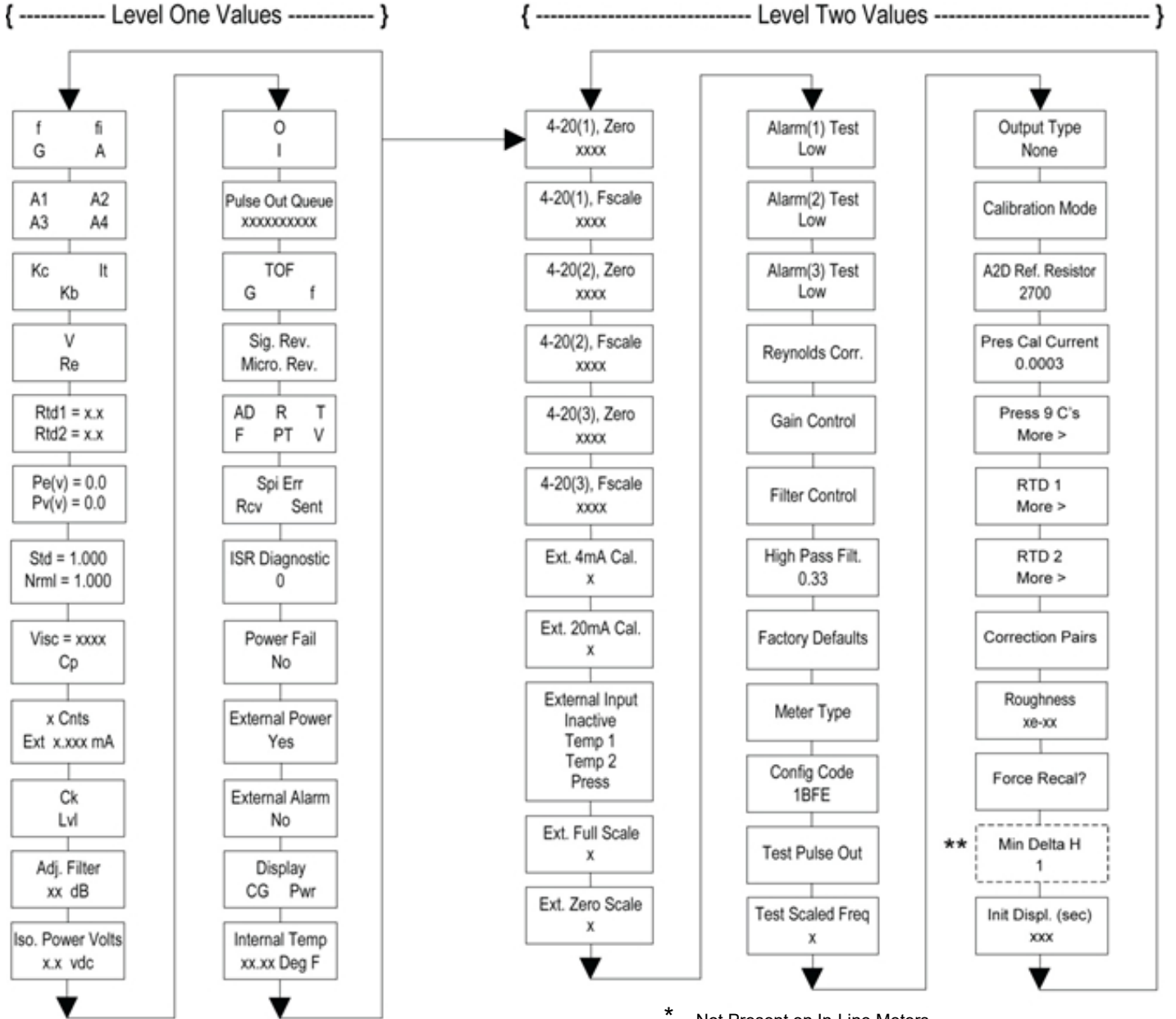

* Not Present on In-Line Meters

** Energy EMS Meters Only

5.1.1 LEVEL One Hidden Diagnostics Values

- **f** = Vortex shedding frequency (Hz)
- **fi** = Adaptive filter – should be approximately 25% higher than the vortex shedding frequency. This is a low-pass filter. If the meter is using the Filter Control (see below) in the manual mode, **fi** will be displayed as **fm**.
- **G** = Gain (applied to vortex signal amplitude). Gain defaults to 1.0 and can be changed using the Gain Control (see below).
- **A** = Amplitude of vortex signal in Volts rms
- **A1, A2, A3, A4** = A/D counts representing the vortex signal amplitude. Each stage (A1-A4) cannot exceed 512. Beginning with stage A1, the A/D counts increase as the flow increases. When stage A1 reaches 512, it will shift to stage A2. This will continue as the flow rate increases until all 4 stages read 512 at high flow rates. Higher flow rates (stronger signal strength) will result in more stages reading 512.
- **Kc, It, Kb** = Profile equation (factory use only). Insertion style only
- **V** = Calculated average pipe velocity (ft/sec)
- **Re** = Calculated Reynolds number
- **RTD1** = Resistance value of integral RTD in ohms
- **RTD2** = Optional RTD resistance value in ohms
- **Pe(v)** = Pressure transducer excitation voltage
- **Pv(v)** = Pressure transducer sense voltage
- **Stnd** = Density of fluid at standard conditions
- **Nrml** = Density of fluid at normal conditions
- **Viscosity** = Calculated viscosity of flowing fluid
- **x Cnts** = A/D counts from the external 4-20 mA input
- **Ext x.xxx mA** = Calculated external 4-20 mA input from the digital counts
- **Ck** = Calculated Ck at current operating conditions. Ck is a variable in the equation that relates signal strength, density, and velocity for a given application. It is used for noise rejection purposes. Ck directly controls the fi value (see above). If the Ck is set too low (in the calibration menu), then the fi value will be too low and the vortex signal will be rejected resulting in zero flow rate being displayed. The calculated Ck value in this menu can be compared to the actual Ck setting in the calibration menu to help determine if the Ck setting is correct.
- **Lvl** = Threshold level. If the Low Flow Cutoff in the calibration menu is set above this value, the meter will read zero flow. The Lvl level can be checked at no flow. At no flow, the Lvl must be below the Low Flow Cutoff setting or the meter will have an output at no flow.
- **Adj. Ffilter** = Adjustable filter. Displays the filtering in decibels. Normally reads zero. If this value is consistently -5 or -10, for example, the Ck or density setting may be wrong.
- **Iso. Power Volts** = Nominally 2.7 VDC. If less than this, check the flow meter input power.
- **O,I** = Factory use only
- **Pulse Out Queue** = Pulse output queue. This value will accumulate if the totalizer is accumulating faster than the pulse output hardware can function. The queue will allow the pulses to “catch up” later if the flow rate decreases. A better practice is to slow down the totalizer pulse by increasing the value in the (unit)/pulse setting in the totalizer menu.

- **TOF, G, f** = Factory use only
- **Sig. Rev** = Signal board hardware and firmware revision
- **Miro Rev** = Microprocessor board hardware and firmware revision
- **AD, R, T, F, PT, V** = Factory use only
- **SPI Err, Rcv, Sent** = Factory use only

5.1.2 LEVEL TWO HIDDEN DIAGNOSTICS VALUES

- **4-20(1) Zero** = Analog counts to calibrate zero on analog output 1.
- **4-20(1) FScale** = Analog counts to calibrate full scale on analog output 1.
- **4-20(2) Zero** = Analog counts to calibrate zero on analog output 2.
- **4-20(2) FScale** = Analog counts to calibrate full scale on analog output 2.
- **4-20(3) Zero** = Analog counts to calibrate zero on analog output 3.
- **4-20(3) FScale** = Analog counts to calibrate full scale on analog output 3.
- **Ext. 4 mA Cal.** = Enter 0 for auto calibration or enter factory supplied A/D counts.
Note: You must connect a known 4 mA input if you are going to calibrate the unit.
- **Ext. 20 mA Cal.** = Enter 0 for auto calibration or enter factory supplied A/D counts.
Note: You must connect a known 20 mA input if you are going to calibrate the unit.
- **External Input** = Enter what the external 4-20 mA input represents; i.e. Temperature 1, Temperature 2, or Pressure. The meter will use this for its internal calculations.
- **Ext. Full Scale** = Enter the full scale units that correlate to the 20 mA point. Note: It must be in the units for the selected input type such as Deg F, Deg C, PSIA, Bar A, etc.
- **Ext. Zero Scale** = Same as above but for the 4 mA point
- **Alarm (1) Test** = Used as a test to verify that the alarm circuit is functioning. When Low is selected, the alarm will initiate a low alarm on the output. When High is selected, it will give a high alarm on the output.
- **Alarm (2) Test** = Used as a test to verify that the alarm circuit is functioning. When Low is selected, the alarm will initiate a low alarm on the output. When High is selected, it will give a high alarm on the output.
- **Alarm (3) Test** = Used as a test to verify that the alarm circuit is functioning. When Low is selected, the alarm will initiate a low alarm on the output. When High is selected, it will give a high alarm on the output.
- **Reynolds Corr.** = Reynolds number correction for the flow profile. Set to Enable for F-2700 insertion, and set to Disable for F-2600 inline.
- **Gain Control** = Manual gain control (factory use only). Leave set at 1.
- **Filter control** = Manual filter control. This value can be changed to any number to force the fi value to a constant. A value of zero activates the automatic filter control which sets fi at a level that floats above the f value.
- **High Pass Filter** = Filter setting – Factory use only
- **Factory Defaults** = Reset factory defaults. If you change this to Yes and press ENTER, all the factory configuration is lost and you must reconfigure the entire program. Consult the factory before performing this process, it is required only in very rare cases.
- **Meter Type** = Insertion or in-line meter
- **Config Code** = Factory use only
- **Test Pulse Out** = Force totalizer pulse. Set to Yes and press ENTER to send one pulse. Very useful to test totalizer counting equipment.
- **Test Scaled Freq** = Enter a frequency value in order to test the scaled frequency output. Return to 0 to stop the test.

- **Calibration Mode** = Factory use only
- **A2D Ref. Resistor** = Factory use only
- **Pressure Cal Current** = Calibration value for the electronics and pressure transducer combination. Consult factory for value.
- **Pressure 9Cs** = Nine pressure coefficients unique to the pressure transducer. Use the \Rightarrow to access all nine coefficients.
 - **Press. Max psi** = Based on installed sensor
- **Press. Min psi** = 0 psia **RTD1**. Press the \Rightarrow to access:
 - **Ro** = RTD resistance at 0°C (1000 ohms)
 - **A** = RTD coefficient A (.0039083)
 - **B** = RTD coefficient B (-5.775e-07)
 - **RTD1 Max Deg. F** = 500
 - **RTD1 Min Deg. F** = -330
- **RTD2** = Second RTD configuration, for special applications only.
- **Correction Pairs**
 - **ft3/sec** (1 through 10)
 - **%Dev.** (1 through 10)
- **Roughness** = Factory use only
- **Force Recal?** = Factory use only
- **Min. Delta H** = Energy EMS meters only. Sets the dead band for totalization to begin. Must be greater than this number (1 default) to initiate the totalizer.
- **Init Displ. (sec)** = Enter a value in seconds to initialize the display every xxx seconds. Enter a value of 0 to disable initializing the display.

5.2 ANALOG OUTPUT CALIBRATION

To check the 4-20 mA circuit, connect a DVM in series with the output loop. Select zero or full scale (from the second level of the hidden diagnostics) and then press the ENTER key twice. This action will cause the meter to output its 4 mA or 20 mA condition. If the DVM indicates a current greater than ± 0.006 mA from 4 or 20, adjust the setting up or down until the output is calibrated. Note: These settings are not for adjusting the output zero and span to match a flow range. That function is located in the Output Menu.

Display Contrast Adjustment

The flow meter display contrast is set at the factory but if the display characters appear too dark or too light proceed as follows:

1. Hold down the “Exit” button on the front panel for 5 to 10 seconds. “Setting Contrast” will appear.
2. Push the “Up” arrow to darken the display or the “Down” arrow to lighten it.
3. Push the “Enter” button to save the contrast setting.

5.3 TROUBLESHOOTING THE FLOW METER



WARNING

Before attempting any flow meter repair, verify that the line is not pressurized. Always remove main power before disassembling any part of the mass flow meter. Use hazardous area precautions if applicable. Static sensitive electronics - use electrostatic discharge precautions.

5.4 FIRST CHECK ITEMS:

- Installation Direction Correct
- Installation Depth Correct (Insertion style meter)
- Power and Wiring Correct
- Application Fluid Correct
- Meter Range Correct for the Application
- Meter Configuration Correct
- Describe Installation Geometry; i.e. upstream diameters, valve position, downstream diameters, etc.

5.5 RECORD VALUES:

Record the following values from the Run Menu with the meter installed in order to determine the operating state of the flow meter:

	With Flow	With No Flow (if possible)
Flow =		
Temperature=		
Pressure =		
Density =		
Error Messages? =		

Record the following values from the Hidden Diagnostics Menu with the meter installed: (Use password 16363 to access.)

	With Flow	With No Flow (if possible)
f =		
fi =		
A =		
A1 =		
A2 =		
A3 =		
A4 =		
V =		

Record values - Hidden Diagnostics Menu continued:

	With Flow	With No Flow (if possible)
Ck =		
Lvl =		
Adj. Filter =		
Iso. Power Volts =		

Record the following values from the Calibration Menu:

Meter Size / Pipe ID =	
Meter Factor =	
Vortex Coef Ck =	
Low Flow Cutoff =	
Serial Number =	

5.6 DETERMINE THE FAULT**5.6.1 Symptom: Output at no Flow**

1. The low flow cutoff is set too low. At no flow, go to the first level of the hidden diagnostics menu and record the Lvl value. The low flow cutoff must be set above this value.
2. Example: At no flow, Lvl = 25. Set the low flow cutoff in the Calibration Menu to approximately 28 and the meter will no longer read a flow rate at no flow.

5.6.2 Symptom: Erratic Output

1. The flow rate may be too low, just at the cutoff of the meter range, and the flow cycles above and below the cutoff making an erratic output. Consult the factory if necessary to confirm the meter range based on current operating conditions. It may be possible to lower the low flow cutoff to increase the meter range. See the example above for output at no flow, only this time the low flow cutoff is set too high. You can lower this value to increase the meter range as long as you do not create the output at no flow condition previously described.
2. Mechanical installation may be incorrect. Verify the straight run is adequate as described in Section 2. For in-line meters, make sure the meter is not installed backwards and there are no gaskets protruding into the flow stream. For insertion meters, verify the insertion depth and flow direction.
3. The meter may be reacting to actual changes in the flow stream. The output can be smoothed using a time constant. The displayed values can be smoothed using the time constant in the Display Menu. The analog outputs can be smoothed using the time constant in the Output Menu. A time constant of 1 will result in the change in value reaching 63% of its final value in one second. A time constant of 4 is 22%, 10 is 9.5% and 50 is 1.9% of the final value in one second. The time constant equation is shown below (TC = Time Constant).

$$\% \text{ Change to final value in one second} = 100(1 - e^{(1/TC)})$$

- The vortex coefficient C_k may be incorrectly set. The C_k is a value in the equation used to determine if a frequency represents a valid vortex signal given the fluid density and signal amplitude. In practice, the C_k value controls the adaptive filter, f_i , setting. During flow, view the f and f_i values in the first level of the hidden diagnostics. The f_i value should be approximately 10-20% higher than the f value. If you raise the C_k setting in the Calibration Menu, then the f_i value will increase. The f_i is a low pass filter, so by increasing it or lowering it, you can alter the range of frequencies that the meter will accept. If the vortex signal is strong, the f_i value will increase to a large number – this is correct.

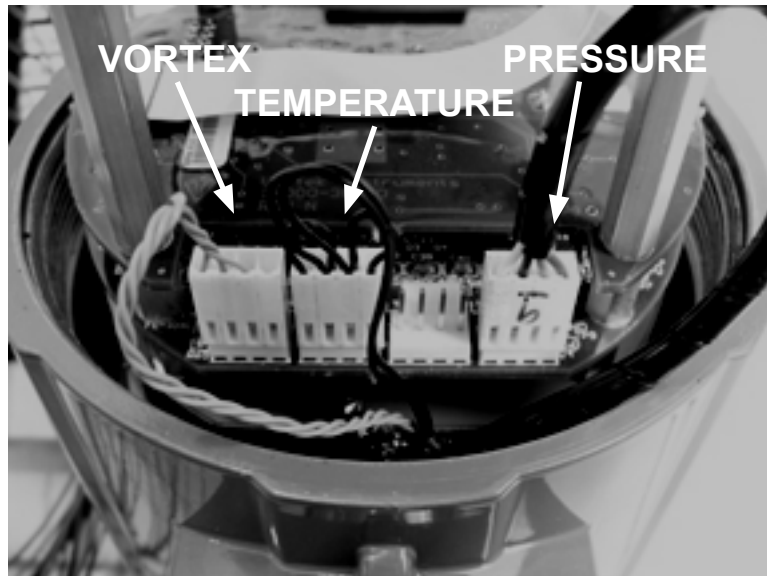

Figure 54. Electronics Stack Sensor Connections

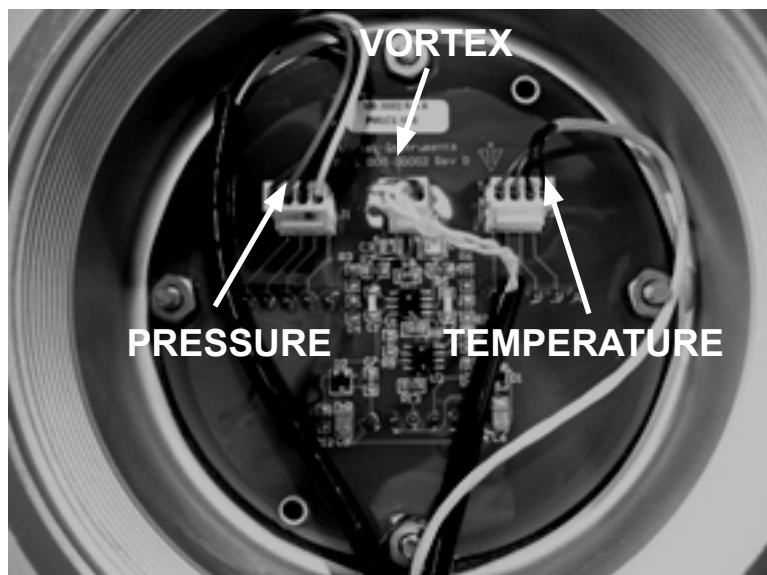

Figure 55. Remote Feed Through Board Sensor Connections

5.6.3 SYMPTOM: NO OUTPUT

1. For remote mounted electronics, carefully check all the wiring connections in the remote mount junction box. There are 18 connections that must be correct. Verify each color (black and red), shield, and wire number.
2. Turn on the pressure and temperature display in the Display Menu and verify that the pressure and temperature are correct.
3. Using ESD precautions and hazardous area precautions, remove the electronics enclosure window cover. Disconnect the vortex sensor from the electronics stack or remote feed through board. Refer to Figure 54 or 55. Measure the resistance from each outside pin to the meter ground. Each should be open. Measure the resistance from the center pin to the meter ground. This should be grounded to the meter.

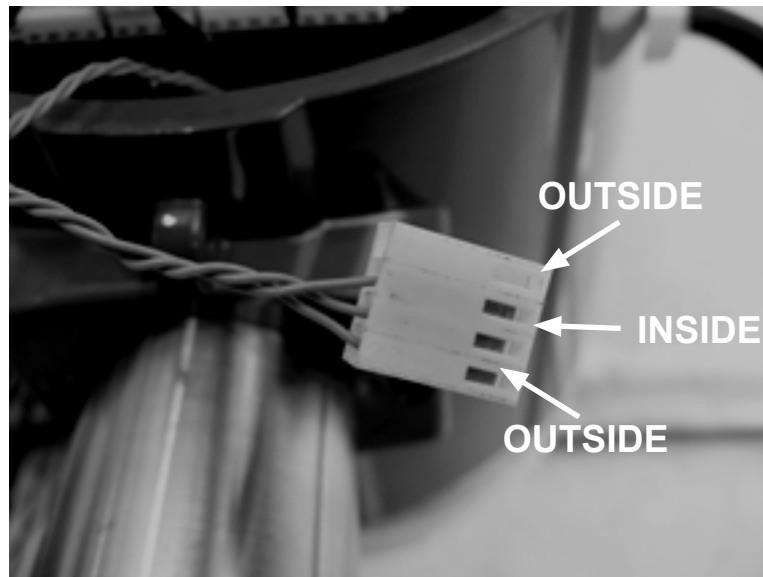

Figure 56. Vortex Sensor Connector

With the sensor still disconnected, go to the first column of the Hidden Diagnostics and display the vortex shedding frequency, f . Hold a finger on the three exposed pins on the analog board. The meter should read electrical noise, 60 Hz for example. If all readings are correct, re-install vortex sensor wires.

4. Verify all meter configuration and troubleshooting steps previously described. There

are many possible causes of this problem. Consult the factory if necessary.

5.6.4 Symptom: Meter Displays Temperature Fault

1. For remote mounted electronics, carefully check all the wiring connections in the remote mount junction box. There are 18 connections that must be correct. Verify each color (black and red), shield, and wire number.
2. Go to the first column of the Hidden Diagnostics and check the resistance of the RTD1. It should be about 1080 ohms at room temperature.
3. Using ESD precautions and hazardous area precautions, remove the electronics enclosure window cover. Disconnect the temperature sensor from the electronics stack or the remote feed through board. Refer to Figure 54 or 55. Measure the resistance across the outside pins of the temperature sensor connector. It should read approximately 1080 ohms at room temperature (higher resistance at higher temperatures).

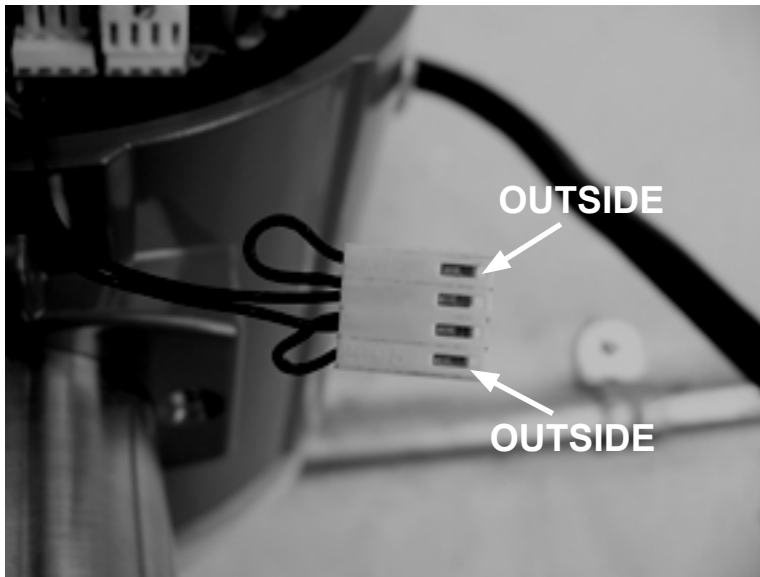

Figure 57. Temperature Sensor Connector

4. Consult the factory with findings

5.6.5 Symptom: Meter Displays Pressure Fault

1. For remote mounted electronics, carefully check all the wiring connections in the remote mount junction box. There are 18 connections that must be correct, verify each color (black and red), shield, and wire number.
2. Using ESD precautions and hazardous area precautions, remove the electronics enclosure window cover. Disconnect the pressure sensor from the electronics stack or the remote feed through board. Measure the resistance across the outside pins of the pressure sensor connector, then across the inside pins. Both readings should be approximately 4400 ohms.

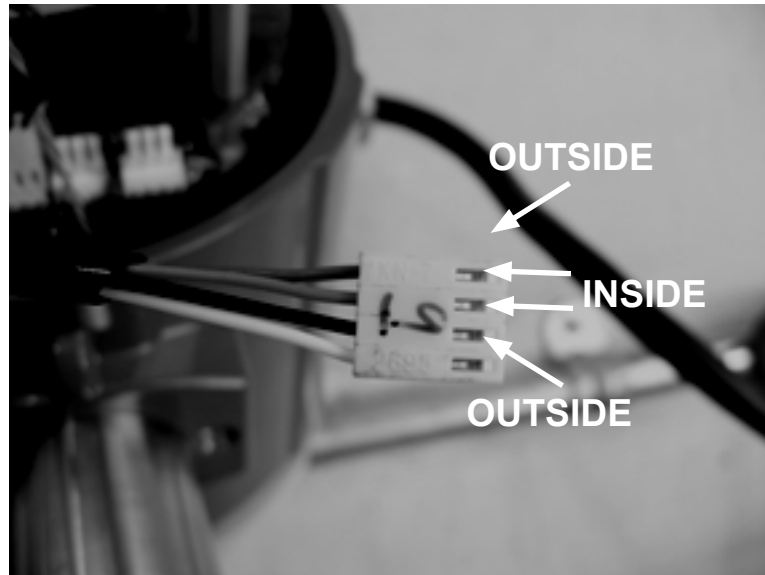

Figure 66. Pressure Sensor Connector

3. Measure the resistance from one of the outside pins to case ground then from one of the inside pins to case ground. They should read open.
4. Go to the first level of the diagnostics and record the Pe(V) and Pv(V) values and consult the factory with findings.

5.7 ELECTRONICS ASSEMBLY REPLACEMENT (ALL METERS)

The electronics boards are electrostatically sensitive. Wear a grounding wrist strap and make sure to observe proper handling precautions required for static-sensitive components.



WARNING

Before attempting any flow meter repair, verify that the line is not pressurized. Always remove main power before disassembling any part of the mass flow meter.

1. Turn off power to the unit.
2. Locate and loosen the small set screw which locks the larger enclosure cover in place. Unscrew the cover to expose the electronics stack.
3. Locate the sensor harnesses which come up from the neck of the flow meter and attach to the circuit boards. Make note of the location of each sensor connection. Refer to figures 53 and 54. The vortex sensor connection is on the left. The temperature sensor connection (if present) is second from the left, and the pressure sensor connection (if present) is the right most connector. Use small pliers to pull the sensor wiring connectors off of the circuit boards.
4. Locate and loosen the small set screw which locks the smaller enclosure cover in place. Unscrew the cover to expose the field wiring strip. Tag and remove the field wires.
5. Remove the screws that hold the black wiring label in place. Remove the label.
6. Locate the 4 Phillips head screws which are spaced at 90° around the terminal board. These screws hold the electronics stack in the enclosure. Loosen these screws (Note: These are captive screws. They will stay inside the enclosure.)
7. Carefully remove the electronics stack from the opposite side of the enclosure. If the electronics stack will not come out, gently tap the terminal strip with the screw driver handle. This will loosen the rubber sealing gasket on the other side of the enclosure wall. Be careful that the stack does not hang up on the loose sensor harnesses.
8. Repeat steps 1 through 6 in reverse order to install the new electronics stack.

5.8 PRESSURE SENSOR REPLACEMENT (IN-LINE ONLY)

1. For local mounted electronics, remove the electronics stack as previously described. For remote mount electronics, remove all wires and sensor connectors from the remote feed through board in the junction box at the meter.
2. Loosen the three set screws at the center of the adapter between the meter and the enclosure.
3. Remove the top half of the adapter to expose the pressure transducer.
4. Remove the transducer and replace it with the new one using appropriate thread sealant.
5. Reassemble in reverse order.

5.9 RETURNING EQUIPMENT TO THE FACTORY

Before returning any flow meter to the factory, you must request a Return Material Authorization (RMA) number. To obtain an RMA number and the correct shipping address, contact customer service at:

727-447-6140 (in the USA).

When contacting customer service, be sure to have the meter serial number and model number ready.

Please see the Meter Troubleshooting Checklist page 96, for additional items which may help with problem isolation. When requesting further troubleshooting guidance, please record the values on the checklist at no flow and during flow if possible.

APPENDIX A PRODUCT SPECIFICATIONS

Accuracy

Process Variables	Inline Meters		Insertion Meters ⁽¹⁾	
	Liquids	Gas & Steam	Liquids	Gas & Steam
Mass Flow Rate	±1% of rate over a 30:1 range ⁽³⁾	±1.5% of rate ⁽²⁾ over a 30:1 range ⁽³⁾	±1.5% of rate over a 30:1 range ⁽³⁾	±2% of rate ⁽²⁾ over a 30:1 range ⁽³⁾
Volumetric Flow Rate	±0.7% of rate over a 30:1 range ⁽³⁾	±1% of rate over a 30:1 range ⁽³⁾	±1.2% of rate over a 30:1 range ⁽³⁾	±1.5% of rate over a 30:1 range ⁽³⁾
Temperature	±2° F (±1° C)	±2° F (±1° C)	±2° F (±1° C)	±2° F (±1° C)
Pressure	0.3% of transducer full scale	0.3% of transducer full scale	0.3% of transducer full scale	0.3% of transducer full scale
Density	0.3% of reading	0.5% of reading ⁽²⁾	0.3% of reading	0.5% of reading ⁽²⁾

Notes:

- (1) Accuracies stated are for the total mass flow through the pipe.
- (2) Over 50 to 100% of the pressure transducer's full scale
- (3) Nominal range-ability is stated. Precise range ability depends on fluid and pipe size.

Repeatability

Mass Flow Rate: 0.2% of rate
 Volumetric Flow Rate: 0.1% of rate
 Temperature: ± 0.2° F (± 0.1° C)
 Pressure: 0.05% of full scale
 Density: 0.1% of reading

Stability Over 12 Months

Mass Flow Rate: 0.2% of rate maximum
 Volumetric Flow Rate: Negligible error
 Temperature: ± 0.1° F (± 0.5° C) maximum
 Pressure: 0.1% of full scale maximum
 Density: 0.1% of reading maximum

Response Time

Adjustable from 1 to 100 seconds

Material Capability

Inline Flow Meter:
 Any gas, liquid or steam compatible with 316L stainless steel, C276 hastelloy or A105 carbon steel. Not recommended for multi-phase fluids.

Insertion Flow Meter:
 Any gas, liquid or steam compatible with 316L stainless steel. Not recommended for multi-phase fluids.

Approvals

FM/FMC Approvals
 Class I, Division 1, Groups B, C, & D
 Class II/III, Division 1, Groups E, F, & G
 Type 4X and IP66, T6, Ta = -40 to 60° C

Flow Rates

Typical mass flow ranges are given in the following table. Precise flow depends on the fluid and pipe size. F-2700 insertion meters are applicable to pipe sizes from 2" and above. Consult the factory for sizing program.

Water Minimum and Maximum Flow Rates									
	½"	¾"	1"	1½"	2"	3"	4"	6"	8"
	15 mm	20 mm	25 mm	40 mm	50 mm	80 mm	100 mm	150 mm	200 mm
gpm	1	1.3	2.2	5.5	9.2	21	36	81	142
	22	40	67	166	276	618	1076	2437	4270

Typical Air Minimum and Maximum Flow Rates (SCFM)									
Air at 70° F									
Nominal Pipe Size (in)									
Pressure	½"	¾"	1"	1½"	2"	3"	4"	6"	8"
0 psig	1.8 18	3 41	5 90	13 221	22 369	50 826	87 1437	198 3258	347 5708
100 psig	5 138	9 325	15 704	38 1730	63 2890	141 6466	245 11254	555 3258	972 44698
200 psig	7 258	13 609	21 1322	52 3248	86 5427	193 12140	335 21131	761 47911	1332 83931
300 psig	8 380	15 896	25 1944	63 4775	104 7978	234 17847	407 31064	922 70431	1615 123375
400 psig	10 502	18 1183	29 2568	72 6309	120 10542	269 23580	467 41043	1060 93057	1857 163000
500 psig	11 624	20 1472	33 3195	80 7849	134 13115	300 28034	521 51063	1182 115775	2071 203000

Linear Range

Smart electronics corrects for lower flow down to a Reynolds number of 5,000. The Reynolds number is calculated using the fluid's actual temperature and pressure monitored by the meter. Range ability depends on the fluid, process connections and pipe size. Consult the factory for your application. Typical velocity range ability in standard applications is as follows:

Liquids 30:1

1 foot per second velocity minimum
30 feet per second velocity maximum

Gases 30:1

10 feet per second velocity minimum
300 feet per second velocity maximum

Minimum and Maximum Saturated Steam Flow Rates @ Specific Operating Pressures									
Pressure	Inline Meter Flow Rates in lb / hr								
	Nominal Diameter (in)								
	½	¾	1	1½	2	3	4	6	8
5 psig	6.5 52	12 122	20 265	49 650	82 1087	183 2431	318 4231	722 9594	1264 16806
15 psig	7.8 74	14.5 195	24 324	59 955	99 1596	222 3570	386 6214	875 14088	1532 24680
50 psig	11.3 153	21 404	35 673	85 1983	143 3313	319 7412	556 12901	1260 29249	2208 51239
75 psig	13.2 209	24.4 550	41 915	100 2698	167 4509	373 10085	648 17554	1470 39801	2575 69723
100 psig	15 271	27 639	46 1386	112 3405	187 5690	419 12729	728 22156	1652 50233	2893 87998
150 psig	18 372	33 980	54 1631	133 4807	222 8033	497 17969	866 31276	1962 70911	3438 124222
200 psig	20 493	37 1163	62 2525	151 6203	253 10365	565 23184	983 40354	2229 91494	3905 160279
300 psig	24 716	45 1688	74 3664	182 9000	304 15040	680 33642	1184 58556	2685 132763	4704 232575

Minimum and Maximum Saturated Steam Flow Rates @ Specific Operating Pressures								
Pressure	Insertion Meter Flow Rates in lb / hr Nominal Diameter (in), Schedule 40 Pipe							
	3	4	6	8	10	12	14	16
5 psig	205	353	800	1385	2184	3099	3746	4893
	2721	4685	10633	18412	29022	41196	49788	65039
15 psig	248	427	969	1679	2646	3756	4539	5930
	3995	6880	15614	27038	42618	60495	73112	95508
50 psig	357	616	1397	2419	3813	5412	6541	9967
	8295	14284	32417	56135	88481	125597	151792	269822
75 psig	417	718	1629	2822	4447	6313	7630	1470
	11288	19438	44112	76385	120401	170907	206551	39801
100 psig	468	807	1831	3170	4996	7092	8571	11197
	14246	24532	55674	96407	151960	215703	260691	340546
150 psig	557	958	2175	3766	5936	8426	10184	13303
	20111	34631	78592	136092	214513	304495	368001	480728
200 psig	632	1089	2470	4278	6743	9572	11568	15111
	25948	44683	101405	175595	276779	392880	474820	620268
300 psig	762	1311	2976	5153	8123	11530	13935	18203
	37652	64838	147145	254799	401623	570093	688994	900047

Linear Range

Smart electronics corrects for lower flow down to a Reynolds number of 5,000. The Reynolds number is calculated using the fluid's actual temperature and pressure monitored by the meter. Range-ability depends on the fluid, process connections and pipe size. Consult factory for your application. Typical velocity range ability in standard applications is as follows:

- Liquids 30:1 1 foot per second velocity minimum
 30 feet per second velocity maximum
- Gases 30:1 10 feet per second velocity minimum
 300 feet per second velocity maximum

Process Fluid Pressure

In-Line Pressure Ratings		
Process Connection	Material	Rating
Flanged	316L SS, A105 Carbon Steel, C276 Hastelloy	150, 300, 600 lb, PN16, PN40, PN64
Wafer	316L SS, A105 Carbon Steel, C276 Hastelloy	600 lb, PN64

Insertion Pressure Ratings			
Probe Seal	Process Connection	Material	Rating
Packing Gland	2" MNPT	316L SS	50 psig
	2" 150 lb flange, DN50 PN16	316L SS	50 psig
	2" 300 lb flange, DN50 PN40	316L SS	50 psig
Packing Gland with Removable Retractor	2" MNPT	316L SS	ANSI 300 lb
	2" 150 lb flange, DN50, PN16	316L SS	ANSI 150 lb
	2" 300 lb flange	316L SS	ANSI 300 lb
Packing Gland with Permanent Retractor	2" MNPT	316L SS	ANSI 600 lb
	2" 150 lb flange, DN50 PN16	316L SS	ANSI 150 lb
	2" 300 lb flange, DN50, PN40	316L SS	ANSI 300 lb
	2" 600 lb flange, DN50 PN64	316L SS	ANSI 600 lb

Pressure Transducer Ranges

Pressure Sensor Ranges ⁽¹⁾ , psia (bara)			
Full Scale Operating Pressure		Maximum Over-Range Pressure	
psia	(bara)	psia	(bara)
30	2	60	4
100	7	200	14
300	20	600	40
500	35	1000	70
1500	100	2500	175

Note: (1) To maximize accuracy, specify the lowest full scale operating pressure range for the application. To avoid damage, the flow meter must never be subjected to pressure above the over-range pressure shown above.

FLANGED METER DIMENSIONS & WEIGHTS

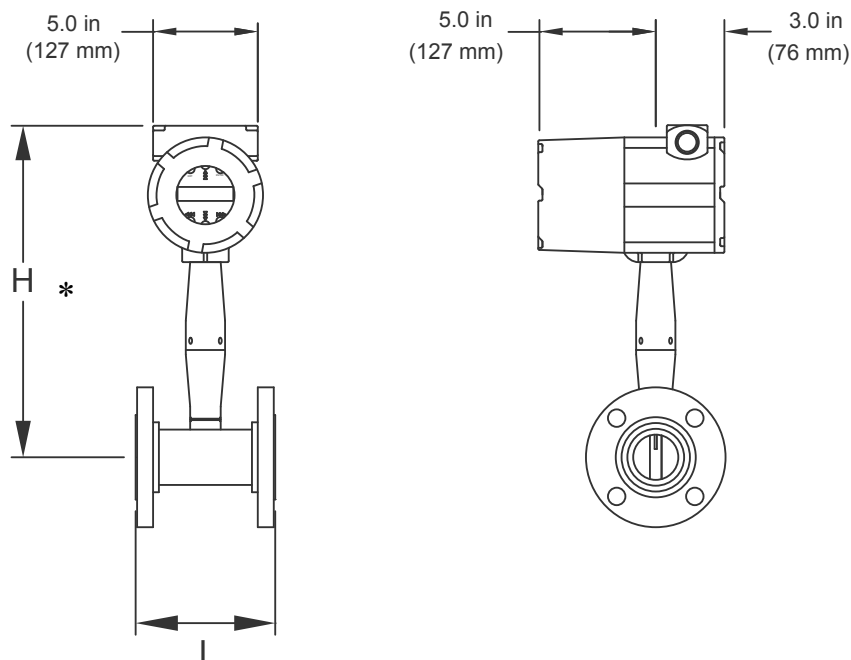

Flow Meter Size	L	H*	Weight		
			ANSI 150 (PN 16)	ANSI 300 (PN 40)	ANSI 600 (PN 64)
½" (15 mm)	7.90 in (200 mm)	13.3 in (338 mm)	13.6 Lb (6.2 Kg)	14.6 Lb (6.6 Kg)	15.2 Lb (6.9 Kg)
¾" (20 mm)	7.9 in (200 mm)	13.4 in (340 mm)	14.7 Lb (6.7 Kg)	17.1 Lb (7.8 Kg)	17.7 Lb (8.0 Kg)
1" (25 mm)	7.9 in (200 mm)	13.5 in (343 mm)	15.6 Lb (7.1 Kg)	18.0 Lb (8.2 Kg)	18.8 Lb (8.5 Kg)
1½" (40 mm)	7.9 in (200 mm)	13.8 in (351 mm)	19.0 Lb (8.6 Kg)	24.2 Lb (11.0 Kg)	26.2 Lb (11.9 Kg)
2" (50 mm)	7.9 in (200 mm)	14.0 in (356 mm)	23.2 Lb (10.5 Kg)	26.8 Lb (12.2 Kg)	30.2 Lb (13.7 Kg)
3" (80 mm)	7.9 in (200 mm)	14.5 in (368 mm)	34.8 Lb (15.8 Kg)	43.4 Lb (19.7 Kg)	48.6 Lb (22.1 Kg)
4" (100 mm)	9.84 in (250 mm)	15.0 in (381 mm)	47.3 Lb (21.5 Kg)	66.5 Lb (30.2 Kg)	88.5 Lb (40.2 Kg)
6" (150 mm)	11.81 in (300 mm)	15.9 in (404 mm)	73.7 Lb (33.5 Kg)	110.5 Lb (50.2 Kg)	169.1 Lb (78.8 Kg)
8" (200 mm)	11.81 in (300 mm)	16.8 in (427 mm)	113.2 Lb (51.4 Kg)	167.2 Lb (75.9 Kg)	253.6 Lb (115.1 Kg)
10" (200 mm)	15.0 in (380 mm)	18.1 in (460 mm)	177.5 Lb (80.6 Kg)	256.7 Lb (116.5 Kg)	418.9 Lb (190.2 Kg)
12" (200 mm)	17.7 in (450 mm)	19.1 in (485 mm)	278.8 Lb (126.6 Kg)	385.6 Lb (175.1 Kg)	526.2 Lb (238.9 Kg)

*This Dimension is the same for integral and remote mount meters.

WAFER METER DIMENSIONS & WEIGHTS

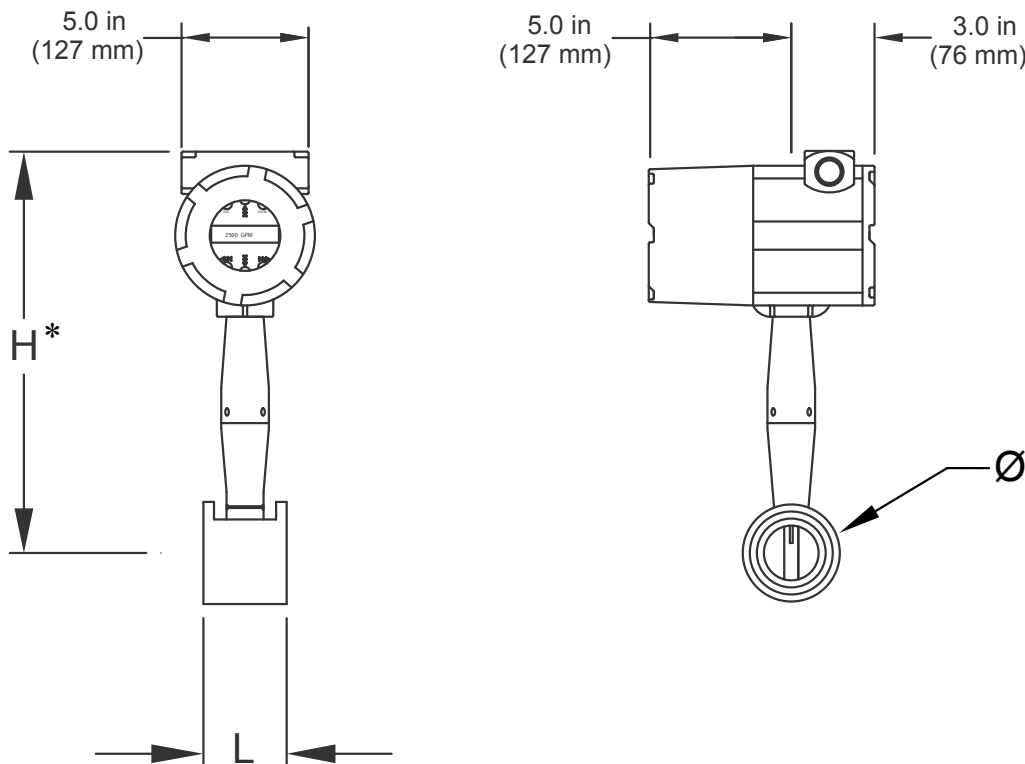

Flow Meter Size	L	H*	Ø	Weight
½" (15 mm)	2.6 in (65 mm)	13.3 in (338 mm)	1.38 in (35 mm)	11.5 Lb (5.2 Kg)
¾" (20 mm)	2.6 in (65 mm)	13.4 in (340 mm)	1.69 in (42.9 mm)	11.9 Lb (5.4 Kg)
1" (25 mm)	2.6 in (65 mm)	13.5 in (343 mm)	2.00 in (50.8 mm)	12.2 Lb (5.5 Kg)
1½" (40 mm)	2.6 in (65 mm)	13.8 in (351 mm)	2.88 in (73.2 mm)	13.8 Lb (6.3 Kg)
2" (50 mm)	2.6 in (65 mm)	14.0 in (356 mm)	3.62 in (91.9 mm)	15.5 Lb (7.0 Kg)
3" (80 mm)	2.6 in (65 mm)	14.5 in (368 mm)	5.00 in (127.0 mm)	20.6 Lb (9.4 Kg)
4" (100 mm)	2.6 in (65 mm)	15.0 in (381 mm)	6.19 in (157.0 mm)	25.3 Lb (11.5 Kg)

*This Dimension is the same for integral and remote mount meters.

Power Requirements 12 to 36 VDC, 25 mA, 1 W max., loop-powered volumetric or, mass
12 to 36 VDC, 300 mA, 9 W max. multiparameter mass options
100 to 240 VAC, 50/60 Hz, 5 W max. multiparameter Mass options

Use a Class 2 isolated power supply that is grounded, provides DC output, and has no more than 10% output ripple.

Installation (Over-voltage) Category II for transient over-voltages

AC & DC mains supply voltage fluctuations are not to exceed ±10% of the rated supply voltage range.

User is responsible for the provision of an external Disconnect Means (and Over-Current Protection) for the equipment (both AC and DC models).

Display Alphanumeric 2 x 16 LCD digital display
Six push-button switches (up, down, right, left, enter, exit) operable through explosion-proof window using hand-held magnet. Viewing at 90° mounting intervals.

Process Fluid and Ambient Temperature Process Fluid:
Standard temperature sensor: -330° F to 500° F (-200° C to 260° C)
High temperature sensor: to 750° F (400° C)
Ambient:
Operating temperature range: -40° F to 140° F (-40° C to 60° C)
Storage temperature range: -40° F to 185° F (-40° C to 85° C)
Maximum relative humidity: 0-98%, non-condensing conditions
Maximum altitude: -2000 to 14,000 feet (-610 to 4268 meters)

Pollution Degree 2 for the ambient environment

Output Signals ⁽¹⁾	<p>Analog: volumetric meter-field range-able linear 4-20 mA output signal (1200 ohms maximum loop resistance) selected by user for mass flow rate or volumetric flow rate.</p> <p>Communications: HART, MODBUS-RTU, RS485, BACnet MS/TP</p> <p>Multiparameter Meter: Up to three field range-able linear 4-20 mA output signals (1200 ohms maximum loop resistance) selected from the five parameters mass flow rate, volumetric flow rate, temperature, pressure and density.</p> <p>Pulse: pulse output for totalization is a 50 millisecond duration pulse operating a solid-state relay capable of switching 40 VDC, 40 mA maximum.</p> <p>Note: (1) All outputs are optically isolated and require external power for operation.</p>
Alarms	Up to three programmable solid-state relays for high, low or window alarms capable of switching 40 VDC, 40 mA maximum.
Totalizer	Based on user-determined flow units, six significant figures in scientific notation. Total stored in non-volatile memory.
Wetted Materials	<p>In-Line Flow Meter: 316L stainless steel standard C276 hastelloy or A105 carbon steel optional</p> <p>Insertion Flow Meter: 316L stainless steel standard Teflon® packing gland below 500° F (260° C) Graphite packing gland above 500° F (260° C)</p>
Enclosure Protection Classification	NEMA 4X and IP66 cast enclosure
Electrical Ports	Two 3/4" female NPT ports
Mounting Connections	<p>In-Line: Wafer, 150, 300, 600 lb ANSI flange, PN16, PN40, PN64 flange</p> <p>Insertion Hot Tap(1) Installation: 2" MNPT; 150, 300, 600 lb ANSI flange, PN16, PN40, PN64 flange and optional retractor with packing gland probe seal.</p> <p>Note: (1) Removable under line pressure.</p>
Mounting Position	<p>In-Line Flow Meter: No effect.</p> <p>Insertion Flow Meter: Meter must be perpendicular within ± 5° of the pipe center line.</p>
Certifications	<p>Material Certificate – US Mill certs on all wetted parts</p> <p>Pressure Test Certificate</p> <p>Certificate of Conformance</p> <p>NACE Certification (MR0175)</p> <p>Oxygen Cleaning (CGA G-4.)</p>

METER ORDERING INFORMATION

Meter Model Number Coding = F-26BB-CDE-FGHI

F-26BB = Inline Vortex Flow Meter

BB = Meter Size (Inches)

- 05 = 1/2" 03 = 3"
- 34 = 3/4" 04 = 4"
- 01 = 1" 06 = 6"
- 15 = 1 1/2" 08 = 8"
- 02 = 2"

C = Process Connection

- 1 = ANSI Class 150 Flange
- 3 = ANSI Class 300 Flange

D = Electronics Enclosure Mounting Configuration

- 1 = Integral mount, NEMA 4X enclosure
- 2 = Remote mount transmitter with 50' of cable
- 3 = Remote mount transmitter with 100' of cable

E = Temperature/Pressure Compensation

- 0 = Integral temperature compensation
- 2 = Integral temp and pressure compensation, 100 psia max
- 3 = Integral temp and pressure compensation, 300 psia max
- 4 = Integral temp and pressure compensation, 500 psia max

F = Input Power

- 0 = Loop power
- 1 = External 12-36 VDC
- 2 = External 100-240 VAC

G = Output Signals

- 0 = Loop powered 4-20 mA and scaled pulse¹
- 1 = One (1) 4-20 mA, one (1) scaled pulse, one (1) alarm contact and MODBUS³
- 2 = One (1) 4-20 mA, one (1) scaled pulse, one (1) alarm contact and BACnet³
- 3 = Three (3) 4-20 mA, one (1) scaled pulse, three (3) alarm contacts and MODBUS³
- 4 = Three (3) 4-20 mA, one (1) scaled pulse, three (3) alarm contacts and BACnet³

¹ Only available for input signal selection F = 0

² Requires remote temperature sensor and installation kit

³ Requires input power F = 1 or 2

H = Max Operating Temperature

- 0 = 500°F

I = Energy Meter Configuration

- 0 = None
- 1 = Gross energy
- 2 = Net energy²

REMOTE TEMPERATURE SENSOR AND THERMOWELL INSTALLATION KIT

(Required for Net Energy Meter)

Model Number	Description
TSI-RKP-1461	4 wire 1000 Ω RTD Sensor, 0.25" X 2.8", 32 - 250°F temperature range with 10" leads
INSTL204S-TSI	Temperature sensor installation kit for pipe size range from 1.5" - 8". Wetted materials are SS, for use in carbon steel piping systems

Note: Net energy meter requires one temperature sensor and one thermowell installation kit sized to pipe.

METER ORDERING INFORMATION

Meter Model Number Coding = F-2700-CDE-FGHI

F-2700 = Insertion Vortex Flow Meter

C = Process Connection

4 = Packing gland with 2" ANSI Class 150 flange and retractor

D = Electronics Enclosure Mounting Configuration

1 = Integral mount, NEMA 4X enclosure

2 = Remote mount transmitter with 50' of cable

3 = Remote mount transmitter with 100' of cable

E = Temperature/Pressure Compensation

0 = Integral temperature compensation

2 = Integral temp and pressure compensation, 100 psia max

3 = Integral temp and pressure compensation, 300 psia max

4 = Integral temp and pressure compensation, 500 psia max

F = Input Power

0 = Loop power

1 = External 12-36 VDC

G = Output Signals

0 = Loop powered 4-20 mA and scaled pulse (only available for input power selection where F = 0)

1 = One (1) 4-20 mA, one (1) scaled pulse, one (1) alarm contact and MODBUS

2 = One (1) 4-20 mA, one (1) scaled pulse, one (1) alarm contact and BACnet

3 = Three (3) 4-20 mA, one (1) scaled pulse, three (3) alarm contacts and MODBUS

REMOTE TEMPERATURE SENSOR AND THERMOWELL INSTALLATION KIT

(Required for Net Energy Meter)

Model Number	Description
TSI-RKP-1461	4 wire 1000 Ω RTD Sensor, 0.25" X 2.8", 32 - 250°F temperature range with 10" leads
INSTL204S-TSI	Temperature sensor installation kit for pipe size range from 1.5" - 8". Wetted materials are SS, for use in carbon steel piping systems

Note: Net energy meter requires one temperature sensor and one thermowell installation kit sized to pipe.

APPENDIX B APPROVALS

FM Approvals

HAZARDOUS (CLASSIFIED) LOCATION ELECTRICAL EQUIPMENT PER US REQUIREMENTS

Certificate No: FM20US0040

HAZARDOUS LOCATION ELECTRICAL EQUIPMENT PER CANADIAN REQUIREMENTS

Certificate No: FM20CA0016

Equipment:

ONICON F-2600 In-Line Multivariable Mass Vortex Flowmeter,

ONICON F-2700 Insertion Multivariable Mass Vortex Flowmeter

ONICON F-1500 Insertion Multivariable Mass Turbine Flowmeter

Mass Flowmeters

ONICON Incorporated

11451 Belcher Road

Largo, FL 33773

United States

The examination and test results are recorded in confidential report number: 3057412 dated 29 February 2016

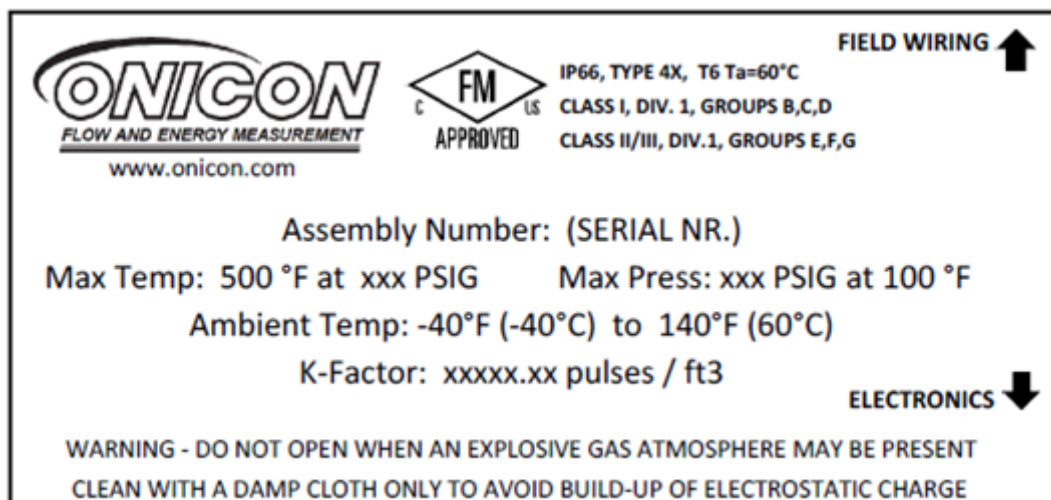

In-Line Flow Meter Calculations**Volume Flow Rate**

$$Q_V = \frac{f}{K}$$

Mass Flow Rate

$$Q_M = Q_V \rho$$

Flowing Velocity

$$V_f = \frac{Q_V}{A}$$

Where:

- A = Cross sectional area of the pipe (ft²)
- f = Vortex shedding frequency (pulses / sec)
- K = Meter factor corrected for thermal expansion (pulses / ft³)
- Q_M = Mass flow rate (lbm / sec)
- Q_V = Volume flow rate (ft³ / sec)
- V_f = Flowing velocity (ft / sec)
- ρ = Density (lbm / ft³)

Insertion Flow Meter Calculations

Flowing Velocity

$$V_f = \frac{f}{K_C}$$

Volume Flow Rate

$$Q_V = V_f A$$

Mass Flow Rate

$$Q_M = V_f A \rho$$

Where:

- A = Cross sectional area of the pipe (ft²)
- f = Vortex shedding frequency (pulses / sec)
- K_C = Meter factor corrected for Reynolds Number (pulses / ft)
- Q_V = Volume flow rate (ft³ / sec)
- Q_M = Mass flow rate (lbm / sec)
- V_f = Flowing velocity (ft / sec)
- ρ = Density (lbm / ft³)

Fluid Calculations

Calculations for Steam T & P

When “Steam T & P” is selected in the “Real Gas” selection of the Fluid Menu, the calculations are based on the equations below.

Density

The density of steam is calculated from the formula given by Keenan and Keys. The given equation is for the volume of the steam.

$$v = \frac{4.555.04 \cdot T}{P} + B$$

$$B = B_0 + B_0^2 g_1(\tau) \tau \cdot p + B_0^4 g_2(\tau) \tau^3 \cdot p^3 - B_0^{13} g_3(\tau) \tau^{12} \cdot p^{12}$$

$$B_0 = 1.89 - 2641.62 \cdot \tau^{1080870\tau^2}$$

$$g^1(\tau) = 82.546 \cdot \tau - 1.6246 \cdot 10^5 \cdot \tau^2$$

$$g^2(\tau) = 0.21828 - 1.2697 \cdot 10^5 \cdot \tau^2$$

$$g^3(\tau) = 3.635 \cdot 10^{-4} - 6.768 \cdot 10^{64} \cdot \tau^{24}$$

Where tau is 1/ temperature in Kelvin.

The density can be found from 1/(v/ standard density of water).

Viscosity

The viscosity is based on an equation given by Keenan and Keys.

$$\eta (\text{poise}) = \frac{1.501 \cdot 10^{-5} \sqrt{T}}{1 + 446.8 / T}$$

Where T is the temperature in Kelvin.

Calculations for Gas (“Real Gas” and “Other Gas”)

Use this formula to determine the settings for “Real Gas; Gas” selections and “Other Gas” selections entered in the Fluid Menu. The calculations for gas were taken from Richard W. Miller, Flow Measurement Engineering Handbook (Third Edition, 1996).

Density

The density for real gases is calculated from the equation:

$$\rho = \frac{GM_{W_{Air}} P_f}{Z_f R_o T_f}$$

Where G is the specific gravity, Mw is the molecular weight of air, pf is the flowing pressure, Z is flowing compressibility, Ro is the universal gas constant, and T is the flowing temperature.

The specific gravity, and Ro are known and are stored in a table used by the vortex meter.

The hard coefficient to find is the compressibility, Z. Z is found using the Redlich-Kwong Equation (Miller page 2-18).

The Redlich-Kwong Equation uses the reduced temperature and pressure to calculate the compressibility factor. The equations are non linear and an iterative solution is used. The vortex program uses Newton’s Method on the Redlich-Kwong equations to iteratively find the compressibility factor. The critical temperature and pressure used in the Redlich-Kwong equation are stored in the fluid data table with the other coefficients.

Viscosity

The viscosity for real gases is calculated using the exponential equation for two known viscosities. The equation is:

$$\mu_{cP} = aT_k^n$$

Where a and n are found from two known viscosities at two temperatures.

$$n = \frac{1n [(\mu_{cP})_2 / (\mu_{cP})_1]}{1n (T_{K2} / T_{K1})}$$

and

$$a = \frac{(\mu_{cP})_1}{T_{K1}^n}$$

Calculations for Liquid

Use this formula to determine the settings for “Goyal-Dorais” selections and “Other Liquid” selections entered in the Fluid Menu. The liquid calculations were taken from Richard W. Miller, Flow Measurement Engineering Handbook (Third Edition, 1996).

Density

The liquid density is found using the Goyal-Doraiswamy Equation. Goyal-Doraiswamy uses the critical compressibility, critical pressure and critical temperature, along with the molecular weight to find the density. The equation for specific gravity is:

$$G_F = \frac{p_c Mw}{T_c} \left(\frac{0.008}{Z_c^{0.773}} - 0.01102 \frac{T_f}{T_c} \right)$$

The specific gravity can then be converted into density.

Viscosity

The liquid viscosity is found by Andrade’s equation. This uses two viscosities at different temperatures to extrapolate the viscosity.

Andrade’s equation:

$$\mu = A_L \exp \frac{B_L}{T_{degR}}$$

To find A and B

$$B_L = \frac{T_{degR1} T_{degR2} \ln (\mu_1 / \mu_2)}{T_{degR}}$$

$$A_L = \frac{\mu_1}{\exp (B_L / T_{degR1})}$$

The temperatures are all in degrees Rankin. Do not believe the subscript R means they are reduced temperatures.

Energy Flow Calculations

Energy is calculated for a steam supply/condensate return or hot/chilled water system. For steam/water, the meter must be located in the supply line; otherwise, the meter may be located in either the supply line or in the return line.

Steam supply, water return, meter steam supply

$$\text{Energy} = \text{mdot} * (\text{h0} - \text{pctRet} * \text{h1})$$

Where:

mdot = mass flow at the meter, lbm/sec

pctRet = estimated percent of mass flow returned

h0 = Steam Enthalpy (t0, p)

h1 = Water Enthalpy (t1)

t0 = steam temperature

t1 = return water temperature

p = steam pressure

Water supply and return, meter supply

$$\text{Energy} = \text{mdot} * (\text{h0} - \text{pctRet} * \text{h1})$$

Where:

h0 = Water Enthalpy (t0)

h1 = Water Enthalpy (t1)

t0 = supply water temperature

t1 = return water temperature

Water supply and return, meter return

$$\text{Energy} = \text{mdot} * (\text{h1}/\text{pctRet} - \text{h0})$$

Where:

h0 = Water Enthalpy (t0)

h1 = Water Enthalpy (t1)

t0 = return water temperature

t1 = supply water temperature

The energy flow is positive if less energy is returned than is supplied. This implies that chilled water systems will indicate negative energy flow. Positive and negative energy flows are accumulated in separate totalizers.

APPENDIX D GLOSSARY

A B C D

A	Cross sectional area
ACFM	Actual Cubic Feet Per Minute (volumetric flow rate)
ASME	American Society of Mechanical Engineers
Bluff Body create	A non-streamlined body placed into a flow stream to vortices. Also called a Shedder Bar
BTU	British Thermal Unit, an energy measurement
Cenelec	European Electrical Code
Compressibility Factor	A factor used to correct for the non-ideal changes in a fluid's density due to changes in temperature and/or pressure
CSA	Canadian Standards Association
d	Width of a bluff body or shedder bar
D	Diameter of a flow channel

E F G H

f	Frequency of vortices generated in a vortex flow meter, usually in Hz
Flow Channel	A pipe, duct, stack, or channel containing flowing fluid
Flow Profile	A map of the fluid velocity vector (usually non-uniform) in a cross-sectional plane of a flow channel (usually along a diameter)
FM	Factory Mutual
Ft	Foot, 12 inches, a measure of length
Ft ²	Square feet, measure of area
Ft ³	Cubic feet, measure of volume
GPM	Gallons Per Minute
Hz	Hertz, cycles per second

I J K L

Inline Flow Meter	A flow meter which includes a short section of piping which is put inline with the user's piping
Insertion Flow Meter	A flow meter which is inserted into a hole in the user's pipeline
Joule	A unit of energy equal to one watt for one second. Also equal to a Newton-meter.
LCD	Liquid crystal display

M N O P

m	Mass flow rate
mA	Milli-amp, one thousandth of an ampere of current
μ	Viscosity-a measure of a fluid's resistance to shear stress. Honey has high viscosity. Alcohol has low viscosity.
nm ³ /hr	Normal cubic meters per hour (flow rate converted to normal conditions, as shipped 101 kPa and 0° C). User definable.
ΔP	Permanent pressure loss
P	Line pressure (psia or bar absolute)
ρ_{act}	The density of a fluid at the actual temperature and pressure operating conditions
ρ_{std}	The density of a fluid at standard conditions (usually 14.7 psia and 20° C)
Permanent Pressure Loss	Unrecoverable drop in pressure
Piezoelectric Crystal	A material which generates an electrical charge when the material is put under stress
PRTD	An resistance temperature detector (RTD) with platinum as its element. Used because of high stability.
psia	Pounds per square inch absolute (equals psig + atmospheric pressure). Atmospheric pressure is typically 14.696 psi at sea level.
psig	Pounds per square inch gauge
PV	Liquid vapor pressure at flowing conditions (psia or bar absolute)

Q R S T**Q**

Flow rate, usually volumetric

Range-ability

Highest measurable flow rate divided by the lowest measurable flow rate

Reynolds Number
or Re

A dimensionless number equal to the density of a fluid times the velocity of the fluid times the diameter of the fluid channel, divided by the fluid viscosity (i.e., $Re = \rho VD/\mu$). The Reynolds number is an important number for vortex flow meters because it is used to determine the minimum measurable flow rate. It is the ratio of the inertial forces to the viscous forces in a flowing fluid.

RTD

Resistance temperature detector, a sensor whose resistance increases as the temperature rises

scfm

Standard cubic feet per minute (flow rate converted to standard conditions, as shipped 14.696 psia and 59° F). User definable.

Shedder Bar

A non-streamlined body placed into a flow stream to create vortices. Also called a bluff body.

Strouhal Number
or St

A dimensionless number equal to the frequency of vortices created by a bluff body times the width of the bluff body divided by the velocity of the flowing fluid (i.e., $St = fd/V$). This is an important number for

vortex flow

meters because it relates the vortex frequency to the fluid velocity.

Totalizer

An electronic counter which records the total accumulated flow over a certain range of time

Traverse

The act of moving a measuring point across the width of a flow channel

U V W X Y Z

Uncertainty

The closeness of agreement between the result of a measurement and the true value of the measurement

V

Velocity or voltage

VAC

Volts, alternating current

VDC

Volts, direct current

VORTEX

An eddy of fluid