

# F-4300

## Clamp-on Ultrasonic Flow Meter Installation & Operation Guide



## **SAFETY INFORMATION**

To ensure correct use of the system, please read this manual thoroughly.

Regarding this manual:

- This manual should be passed on to the end user.
- Before use, read this manual thoroughly to comprehend its contents.
- The contents of this manual may be changed without prior notice.
- All rights reserved. No part of this manual may be reproduced in any form without ONICON Incorporated's written permission.
- ONICON Incorporated makes no warranty of any kind with regard to this material, including, but not limited to, implied warranties of merchantability and suitability for a particular purpose.
- All reasonable effort has been made to ensure the accuracy of the contents of this manual. However, if any errors are found, please inform ONICON Incorporated.
- ONICON Incorporated assumes no responsibilities for this product except as stated in the warranty.
- If the customer or any third party is harmed by the use of this product, ONICON Incorporated assumes no responsibility for any such harm owing to any defects in the product which were not predictable, or for any indirect damages.

### **SAFETY PRECAUTIONS:**

The following general safety precautions must be observed during all phases of installation, operation, service, and repair of this product. Failure to comply with these precautions or with specific WARNINGS given elsewhere in this manual violates safety standards of design, manufacture, and intended use of the product. ONICON Incorporated assumes no liability for the customer's failure to comply with these requirements. If this product is used in a manner not specified in this manual, the protection provided by this product may be impaired.

The following messages are used in this manual:

#### **WARNING**

***Messages identified as "WARNING" contain information regarding the personal safety of individuals involved in the installation, operation or service of this product.***

#### **CAUTION**

***Messages identified as "CAUTION" contain information regarding potential damage to the product or other ancillary products.***

#### **IMPORTANT NOTE**

***Messages identified as "IMPORTANT NOTE" contain information critical to the proper operation of the product.***

**TABLE OF CONTENTS**

**SECTION 1.0 GENERAL INFORMATION .....5**

1.1 PRINCIPLE OF OPERATION ..... 5

1.2 TYPICAL F-4300 FLOW METER INSTALLATION ..... 5

1.3 STANDARD FEATURES AND SPECIFICATIONS\* ..... 6

1.4 MODEL NUMBERING CODIFICATION ..... 8

1.5 ADDITIONAL HARDWARE THAT MAY BE REQUIRED ..... 9

1.6 WORKING ENVIRONMENT ..... 9

1.7 MAINTENANCE ..... 9

1.8 SERIAL NUMBER ..... 9

**SECTION 2.0 UNPACKING .....10**

2.1 CHECKING THAT YOU HAVE RECEIVED EVERYTHING .....10

**SECTION 3.0 INSTALLATION .....11**

3.1 OVERVIEW ..... 11

    3.1.1 Two (2) (Reflect) or Four (4) (Double Reflect) Cross Mode .....12

    3.1.2 One (1) (Direct) Cross Mode .....12

3.2 SITE SELECTION .....13

    3.2.1 The Wall-Mount Enclosure .....13

    3.2.2 The Transducers .....14

    3.2.3 Transducer Mounting Recommendations .....15

3.3 MECHANICAL INSTALLATION .....16

    3.3.1 Dimensions .....16

        3.3.1.1 Enclosure Dimensions .....16

        3.3.1.2 10 Series Transducer Dimensions .....17

        3.3.1.3 20 Series Transducer Dimensions .....17

        3.3.1.4 30 Series Transducer Dimensions .....18

    3.3.2 10 Series Mechanical Installation .....19

        3.3.2.1 Preparing the Pipe for 10 Series Transducers .....19

        3.3.2.2 Two (2) or Four (4) Cross Mounting Installation for 10 Series Transducers .....20

    3.3.3 20 Series Mechanical Installation .....21

        3.3.3.1 Preparing the Pipe for 20 Series Transducers .....21

        3.3.3.2 Two (2) or Four (4) Cross Mounting Installation for 20 Series Transducers .....22

        3.3.3.3 One (1) Cross Mounting Installation for 20 Series Transducer .....25

    3.3.4 30 Series Mechanical Installation .....30

        3.3.4.1 Preparing the Pipe for 30 Series Transducers .....30

        3.3.4.2 Two (2) Cross Mounting Installation for 30 Series Transducers .....31

        3.3.4.3 One (1) Cross Mounting Installation for 30 Series Transducers .....33

3.4 CONNECTING THE TRANSDUCER SIGNAL CABLES.....37

3.5 ELECTRICAL INSTALLATION .....38

    3.5.1 Input Power Requirements .....38

    3.5.2 Power and Output Signal Wiring Details .....39

    3.5.3 Transducer and Sensor Wiring Details .....40

**SECTION 4.0 START-UP.....41**

    4.1 NAVIGATING THE RUN MODE & PROGRAMMING PAGES .....41

    4.2 RUN MODE & PROGRAMMING PAGE LAYOUT .....42

    4.3 RUN MODE ICONS.....43

    4.4 RUN MODE PAGES.....44

    4.5 PROGRAMMING MENU PAGES .....46

**SECTION 5.0 BACNET MS/TP.....55**

    5.1 BACNET PROTOCOL IMPLEMENTATION CONFORMANCE STATEMENT .....56

**SECTION 6.0: MODBUS.....61**

    6.1 MODBUS RTU RS485.....61

    6.2 MODBUS TCP/IP.....61

        6.2.1 IP Address Setting (IPv4) .....62

        6.2.2 IP Address Setting (IPv6) .....64

    6.3 UNITS AND FUNCTIONS.....64

    6.4 MODBUS MEMORY MAP .....65

    6.5 REPORT SLAVE ID FUNCTION CODE.....72

**SECTION 7.0: COMMISSIONING .....73**

    7.1 HELPFUL HINTS FOR START-UP AND COMMISSIONING .....73

    7.2 COMMISSIONING PROCEDURE .....73

    7.3 COMMISSIONING WORKSHEET.....74

**SECTION 8.0: TROUBLESHOOTING.....75**

**APPENDIX A - SPEED OF SOUND IN PURE WATER TABLE (IMPERIAL UNITS) .....76**

**APPENDIX B - SPEED OF SOUND IN PURE WATER TABLE (SI UNITS) .....77**

**APPENDIX C - SPEED OF SOUND IN GLYCOL WATER TABLE.....78**

**APPENDIX D - PIPE CHARTS.....79**

## SECTION 1.0 GENERAL INFORMATION

ONICON Incorporated would like to thank you for purchasing our F-4300 Clamp-on Ultrasonic Flow Meter. As our valued customer, our commitment to you is to provide fast reliable service, while continuing to offer quality products to meet your growing flow measurement needs.

### 1.1 PRINCIPLE OF OPERATION

The ONICON F-4300 Clamp-on Ultrasonic Flow Meter utilizes the differential transit time method to measure the velocity of relatively clean liquids in full pipes. By measuring the difference between transit times of ultrasonic sound waves traveling between two transducers, the flow velocity and direction are accurately determined.

### 1.2 TYPICAL F-4300 FLOW METER INSTALLATION

The F-4300 Ultrasonic Flow Meter utilizes clamp-on signal transducers that mount on the outside wall of the pipe. It is suitable for measuring the volumetric flow of liquids in a wide variety of applications including bi-directional flow applications. The meter is housed in a NEMA 4X (IP67) polycarbonate wall-mounted enclosure with a built-in user interface/display.

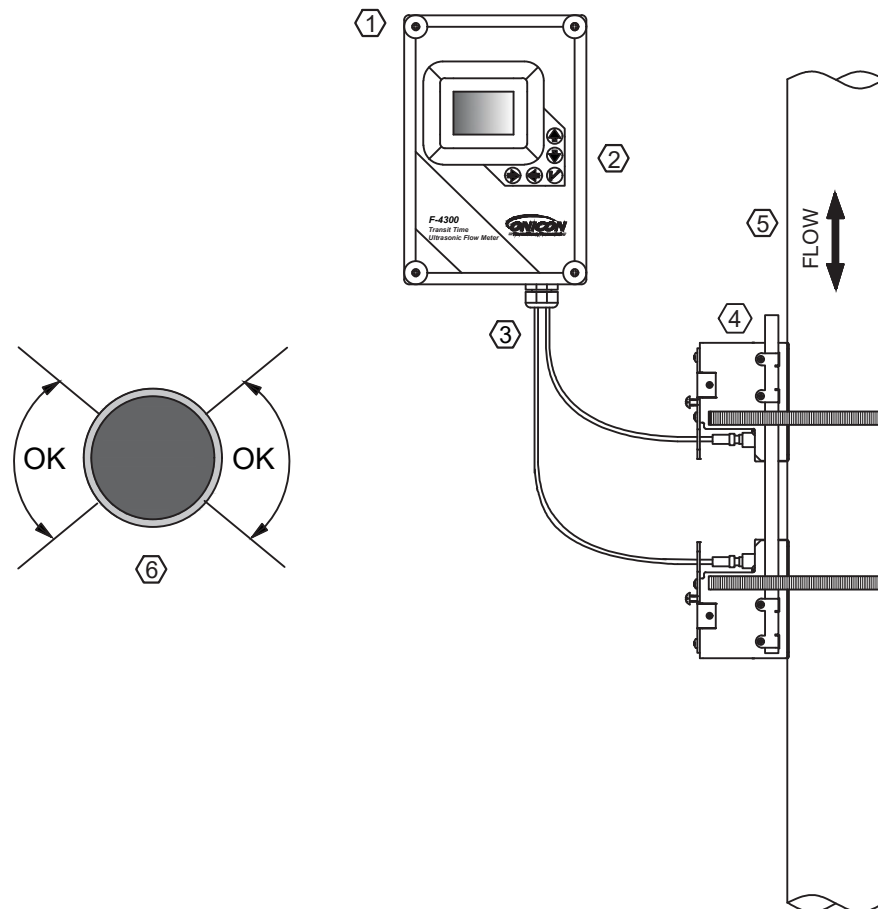

1. NEMA 4X (IP67) polycarbonate with clear shatter proof cover
2. Backlit LCD display with menu, driven via five (5) programming keys.
3. Triaxial transducer cables. The maximum allowable cable length is 100 ft.
4. Mounting hardware, includes: mounting brackets, mounting strap kit and an alignment and spacer tool. Refer to section 2.1 for more installation hardware options.
5. Vertical pipe: mounting on a vertical pipe is recommended, when flow is in the upward direction. When mounting on a vertical pipe flowing in a downward direction, make sure there is sufficient back pressure in the system to maintain a full pipe.
6. Horizontal pipe: avoid mounting transducers on the top of a horizontal pipe. The best placement on a horizontal pipe is either the 2:00 to 4:00 or 8:00 to 10:00 positions for two (2) cross (Reflect) or four (4) cross (Double Reflect) mode, or one sensor at 9:00 and one sensor at 3:00 for one (1) cross mode (Direct).

1.3 STANDARD FEATURES AND SPECIFICATIONS\*

| F-4300 TRANSMITTER               |  |   |
|----------------------------------|--|---|
| TRANSMITTER PERFORMANCE          | ACCURACY   | ± 1.0% of reading from 1.5 to 40 ft/s (0.46 to 12.2 m/s) (26:1 range)<br>± 0.015 ft/s (±0.0046 m/s) for velocities below 1.5 ft/s (0.46 m/s)  |
|                                  | REPEATABILITY & LINEARITY  | ± 0.25%   |
| DIFFERENTIAL TEMPERATURE SENSORS | Temperature sensors meet EN1434/CSA C900.1 accuracy requirements for 1K sensors for cooling applications, 32°F to 77°F<br>Temperature sensors meet EN1434/CSA C900.1 accuracy requirements for 2K sensors for heating applications, 140°F to 212°F |   |
|                                  | ONICON CURRENT BASED TEMP SENSOR**   | Precision solid state current based sensors. Signal (mA) is unaffected by wire length. Overall differential temperature measurement uncertainty of ± 0.15°F over the application range  |
|                                  | PT1000 RTD TEMP SENSOR**   | 1000Ω platinum RTDs calibrated to a differential measurement uncertainty of ± 0.18°F over the stated range  |
| OPERATING CONDITIONS             | AMBIENT OPERATING  | -5°F to 140°F   |
| INPUT POWER                      | AVAILABLE OPTIONS  | <ul style="list-style-type: none"> <li>• 24 V AC/DC, 50/60 Hz, 10 VA max</li> <li>• 110-240 VAC, 50/60 Hz, 10 VA max</li> </ul>   |
| I/O SIGNAL                       | ANALOG OUTPUT(S)   | Flow Meter: One (1) isolated AO, 4-20 mA or 0-5 VDC<br>BTU Meter Option: Three (3) isolated AOs, 4-20 mA or 0-5 VDC   |
|                                  | DIGITAL OUTPUTS  | Flow Meter: Two (2) programmable DOs, SPST, form A, N.O.<br>BTU Meter Option: Six (6) programmable DOs<br>DO 1-2 : SPST, form A, N.O.<br>DO 3-6: SPDT, form C<br>Pulse duration: 500 ms<br>Min. pulse interval: 2s<br>Max. load voltage/current: 50V/ 250mA AC/DC |
|                                  | DIGITAL INPUTS   | BTU Meter Option: Three (3) DIs<br>For use with open collector sinking or contact closure outputs<br>Input voltage logic low: < 0.5 VDC<br>Input voltage logic high range: 5 - 24 VDC<br>Min. pulse interval: 2s  |
| ELECTRONICS ENCLOSURE            | NEMA 4X (IP67) polycarbonate enclosure with clear shatter proof cover  |   |
|                                  | DISPLAY  | Large, easy to read, backlit, 128 x 64 dot matrix display   |
|                                  | DATA LOGGER  | Built-in 128 MB data logger with type A USB output. Capacity for 26 million data points   |
| PROGRAMMING                      | Menu driven via five (5) programming keys  |   |
| ELECTRICAL CONNECTIONS           | Enclosed terminal blocks, cable access through three (3) ½" conduit openings for signal and power, and one (1) ¾" conduit opening for transducer cables.   |   |
| NETWORK CONNECTIONS              | AVAILABLE OPTIONS  | <ul style="list-style-type: none"> <li>• RS485 serial interface, BACnet MS/TP (default) or MODBUS RTU</li> <li>• Optional MODBUS TCP/IP (24 VDC only)</li> </ul>  |

\* SPECIFICATIONS subject to change without notice.

\*\* Installation hardware are provided separately.

Refer to F-4300 Thermal Energy Measurement System Addendum for more details on BTU meter options.

1.3 STANDARD FEATURES AND SPECIFICATIONS\* (CONTINUED)

|                                    |                         |  |
|------------------------------------|-------------------------|--|
| NETWORK CONFIGURATION & ADDRESSING | BAUD RATES              | 4800, 9600, 19200, 38400, or 76800   |
|                                    | DEVICE ADDRESS RANGE    | 1 - 247  |
|                                    | DEVICE INSTANCE RANGE   | 1 – 4,194,302 (BACnet® only)   |
|                                    | PARITY                  | None, Even, Odd (MODBUS® RTU only)   |
| APPROVALS                          | CE                      | 2014/30/EU EMC Directive   |
| <b>F-4300 FLOW SENSOR</b>          |                         |  |
| PERFORMANCE                        | SENSING METHOD          | Ultrasonic differential transit time velocity measurement via non-wetted transducers   |
| OPERATING CONDITIONS               | FLUID PROPERTIES        | Clean liquids in full (pressurized) pipes  |
|                                    | FLUID VELOCITY RANGE    | 0.07 ft/s to 40 ft/s   |
|                                    | FLUID TEMPERATURE RANGE | -40°F to 250°F   |
|                                    | PIPE MATERIALS          | Suitable for use in a wide range of metallic and non-metallic piping systems   |
|                                    | PIPE SIZE RANGE         | 1/2" through 48", based on transducer series selected.   |
| TRANSDUCER DESIGN - 10 SERIES      | OPERATING FREQUENCY     | 2.56 Mhz   |
|                                    | PIPE SIZE RANGE         | 1/2" through 4"  |
|                                    | TRANSDUCER HOUSING      | CF8M 316 Stainless Steel   |
|                                    | CABLE CONNECTIONS       | <ul style="list-style-type: none"> <li>• Triax cable with BNC style connectors and sealing jacket</li> <li>• Triax cable with NEMA 6 (IP67) direct connection for wet locations</li> </ul> |
|                                    | MOUNTING KIT            | 304 Stainless Steel mounting brackets with conduit connection, 200 Series Stainless Steel pipe clamps, and alignment and spacer tool   |
| TRANSDUCER DESIGN - 20 SERIES      | OPERATING FREQUENCY     | 1.28 Mhz   |
|                                    | PIPE SIZE RANGE         | 2" through 10"   |
|                                    | TRANSDUCER HOUSING      | CF8M 316 Stainless Steel   |
|                                    | CABLE CONNECTIONS       | Triax cable with BNC style connectors and sealing jacket   |
|                                    | MOUNTING KIT            | 304 Stainless Steel mounting brackets with conduit connection, 200 Series Stainless Steel pipe clamps, and alignment and spacer tool   |
| TRANSDUCER DESIGN - 30 SERIES      | OPERATING FREQUENCY     | 640 kHz  |
|                                    | PIPE SIZE RANGE         | 12" through 48"  |
|                                    | TRANSDUCER HOUSING      | CF8M 316 Stainless Steel   |
|                                    | CABLE CONNECTIONS       | Triax cable with BNC style connectors and 1/2" MNPT conduit connection and NEMA 4 (IP66) threaded strain relief.   |
|                                    | MOUNTING KIT            | 304 Stainless Steel mounting brackets with conduit connection, 200 Series Stainless Steel pipe clamps, and alignment and spacer tool   |

\* SPECIFICATIONS subject to change without notice.

## 1.4 MODEL NUMBERING CODIFICATION

### Meter Model Number Coding = F-4300-ABCD-EEFF-GG

#### A = Electronics Enclosure

1 = NEMA 4X Polycarbonate

#### B = Input Power

1 = 24 V AC/DC

2 = 110 - 240 VAC

#### C = Feature Set & I/O

1 = Flow only, one (1) AO, two (2) DO and RS485, BACnet or MODBUS

2 = Flow only, one (1) AO, two (2) DO and MODBUS TCP/IP <sup>1</sup>

3 = Flow and Energy, three (3) AO, three (3) DI, six (6) DO and RS485, BACnet or MODBUS

4 = Flow and Energy, three (3) AO, three (3) DI, six (6) DO and MODBUS TCP/IP <sup>1</sup>

#### D = Transducer Cable Length

1 = 25' transducer cable, BNC connector <sup>2</sup>

2 = 50' transducer cable, BNC connector <sup>2</sup>

3 = 100' transducer cable, BNC connector <sup>2</sup>

4 = 25' transducer cable, submersible connection (NEMA 6 - IP67) <sup>3</sup>

5 = 50' transducer cable, submersible connection (NEMA 6 - IP67) <sup>3</sup>

6 = 100' transducer cable, submersible connection (NEMA 6 - IP67) <sup>3</sup>

7 = 25' transducer cable, BNC connector, threaded strain relief (NEMA 4 - IP66) <sup>4</sup>

8 = 50' transducer cable, BNC connector, threaded strain relief (NEMA 4 - IP66) <sup>4</sup>

9 = 100' transducer cable, BNC connector, threaded strain relief (NEMA 4 - IP66) <sup>4</sup>

#### EEFF = Transducer Series & Installation Hardware

1212 = Includes pair of 10 Series transducer, 37 deg. w/ 1/2" to 4" nom. pipe diameter SS mounting bracket

2X21 = Includes pair of 20 Series transducer, 35 to 41 deg. w/ 2" to 6" nom. pipe diameter SS mounting bracket <sup>5</sup>

2X22 = Includes pair of 20 Series transducer, 35 to 41 deg. w/ 8" to 10" nom. pipe diameter SS mounting bracket <sup>5</sup>

3231 = Includes pair of 30 Series transducer, 37 deg. w/ 12" to 16" nom. pipe diameter SS mounting bracket

3232 = Includes pair of 30 Series transducer, 37 deg. w/ 18" to 48" nom. pipe diameter SS mounting bracket

#### GG = Temperature Sensor Selection

00 = Flow only

O1 = Matched pair of current (mA) based sensors, CHW/CW range <sup>6</sup>

O2 = Matched pair of current (mA) based sensors, HHW range <sup>6</sup>

R2 = Matched pair of 4 wire PT1000 RTDs, 1/2" to 2 1/2" line size, 32°F to 250°F <sup>6</sup>

R3 = Matched pair of 4 wire PT1000 RTDs, 3" and larger line size, 32°F to 250°F <sup>6</sup>

S6 = Matched pair of PT100 current (mA) based sensors, -4°F to 104°F <sup>6</sup>

#### Notes

<sup>1</sup> MODBUS TCP/IP requires 24 VDC input power

<sup>2</sup> Only available for transducer series EEFF = 1212, EEFF = 2X21 and EEFF = 2X22

<sup>3</sup> Only available for transducer series EEFF = 1212

<sup>4</sup> Only available for transducer series EEFF = 3231 and EEFF = 3232

<sup>5</sup> Actual transducer selected, 21 through 24, is factory selected at time of order

<sup>6</sup> Only available for feature set C = 3 and C = 4



**1.5 ADDITIONAL HARDWARE THAT MAY BE REQUIRED**

Flex conduit may be required to connect transducer mounting bracket to rigid conduit. Do not connect transducer mounting brackets to rigid conduit.

**1.6 WORKING ENVIRONMENT**

The F-4300 was designed for installation and use in typical commercial/ industrial environments. The following considerations must be observed in selecting a location for the meter:

- The ambient operating temperature range is -5°F (-20°C) to 140°F (60°C).
- Do not expose the meter to corrosive liquids or fumes.
- Avoid installation locations that are close to strong sources of electrical interference.
- Avoid installing the electronics enclosure in direct sunlight.
- Avoid installation locations where the transducers will be exposed to vibrations in the piping system.
- Always run transducer cables in dedicated conduit separate from signal and power cables.
- Do not run signal cables for the meter in conduit with mains (AC) power cables.

**1.7 MAINTENANCE**

Periodically inspect the power cables, transducer cables, cable glands and the enclosure for signs of damage. Inspect transducer installation and mounting hardware for loose connections or diminished ultrasonic couplant.

**1.8 SERIAL NUMBER**

The serial number of your F-4300 is located outside and inside the enclosure. Transducers will be packaged inside the enclosure they were calibrated with and will bear their own unique serial numbers. You should have one of these serial numbers available when contacting ONICON for assistance regarding your meter.

## SECTION 2.0 UNPACKING

The F-4300 is generally shipped in one package. Notify the freight carrier and ONICON if any items are damaged in transit.

### 2.1 CHECKING THAT YOU HAVE RECEIVED EVERYTHING

#### Documentation

Enclosed with each F-4300 is a comprehensive documentation package that includes the following items:

- One (1) F-4300 Clamp-on Ultrasonic Flow Meter Installation and Operation Guide
- One (1) Flow Meter Certificate of Calibration
- One (1) Site Installation Details Document

Please notify ONICON if any of these items are missing.

#### The Wall Mount Enclosure

Remove the F-4300 enclosure from the shipping carton and inspect it inside and out for physical damage. Please notify ONICON immediately if you discover any damage.

Inspect the transducers for signs of damage. Each transducer will have a label attached with a serial number associated with it that can be found on the F-4300 enclosure.

#### Transducer Cables

##### BNC Connector for 10 and 20 Series Transducers

10 Series and 20 Series transducer cables are coiled and included inside the shipping carton. One end of each cable is already terminated with a BNC connector for connection to the transducers. The other end is pre-terminated for connection to the electronics.

##### Submersible Connection (NEMA 6 - IP67) for 10 Series Transducers

10 Series transducer cables are coiled and included inside the shipping carton. One end of each cable is terminated and connected to the transducers. The other end is pre-terminated for connection to the electronics.

##### Threaded Strain Relief Connection (NEMA 4 - IP66) for 30 Series Transducers

30 Series transducer cables are coiled and included inside the shipping carton. One end of each cable is terminated with a threaded strain relief connector for connection to the transducers. The other end is pre-terminated for connection to the electronics.

#### Installation Hardware Includes:

- Two (2) mounting brackets
- One (1) Site Installation Detail which include the transducer spacing unique to the application
- One (1) alignment and spacer tool
- One (1) tube of coupling compound
- One (1) mounting kit that includes:
  - Pipe straps
  - Mylar sleeve
  - Duct tape
  - Level
  - Black Sharpie
  - Sanding block

#### IMPORTANT NOTE

***The ONICON F-4300 Clamp-on Ultrasonic Flow Meter is a custom calibrated system. Unless specifically noted in writing by ONICON, ALL COMPONENTS must be installed together as a system. Mixing components from different systems will result in significant errors in measurement.***

## SECTION 3.0 INSTALLATION

### 3.1 OVERVIEW

Each F-4300 Clamp-on Ultrasonic Flow Meter is provided with a pair of matched ultrasonic transducers. The transducers are mounted (clamped) on to the outside wall of the pipe. Triaxial cables convey the transducer signals to the wall mount enclosure containing the signal processing circuitry and the user interface display.

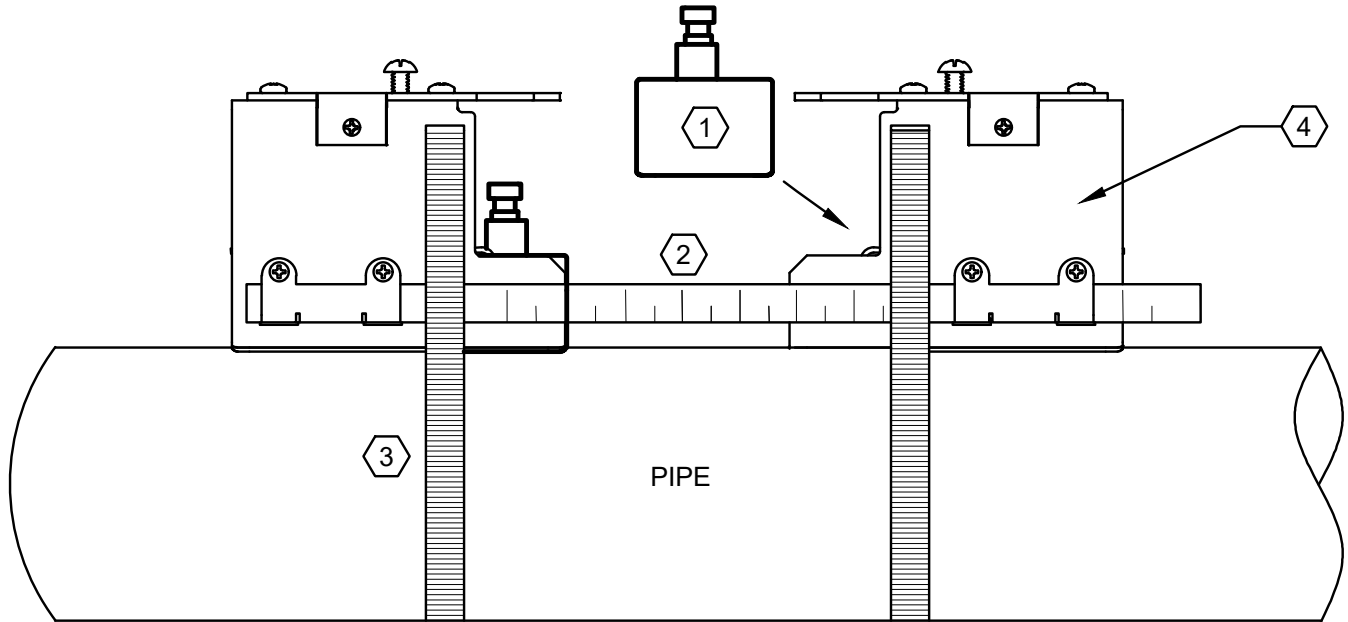

1. Transducer
2. Alignment and spacer tool
3. Adjustable stainless steel pipe clamp
4. Transducer mounting bracket

Ultrasonic transducers can be configured to operate in either 1 (Direct), 2 (Reflect) or 4 (Double Reflect) cross operating modes. The choice of operating mode is dictated by the configuration settings programmed into the meter. For new installations, configuration data is programmed into the meter prior to shipment. Programming data determines the transducer operating mode and the spacing between the transducers.

**3.1 OVERVIEW (Continued)**

**3.1.1 Two (2) (Reflect) or Four (4) (Double Reflect) Cross Mode**

Two (2) cross (Reflect) mode is the recommended operating mode whenever possible. It is the simplest way to mount the transducers. Operating in the reflect mode also minimizes the effects of some flow distortions.

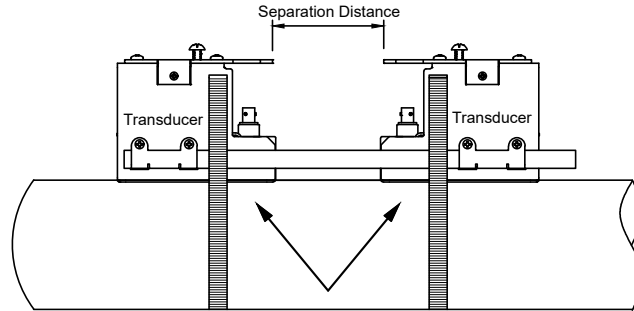

2 CROSS SEPARATION DISTANCE (REFLECT)

Four (4) cross (Double Reflect) mode is used for some installations in small pipe sizes using the 10 Series transducers.

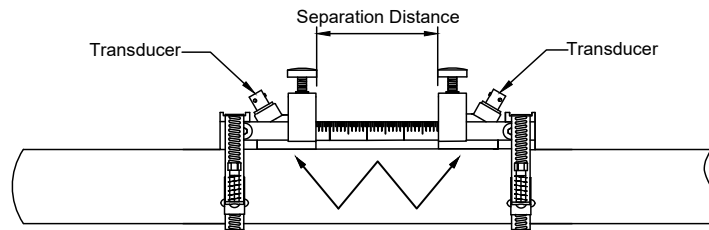

4 CROSS SEPARATION DISTANCE (DOUBLE REFLECT)

**3.1.2 One (1) (Direct) Cross Mode**

One (1) cross mount provides a shorter sonic path. The shorter path typically improves performance with difficult pipe conditions, such as older and/ or corroded piping. One (1) cross (Direct) mounting requires half the distance between transducers when compared to the two (2) cross (Reflect) mode and may be the only option if the availability of the mounting space is limited.

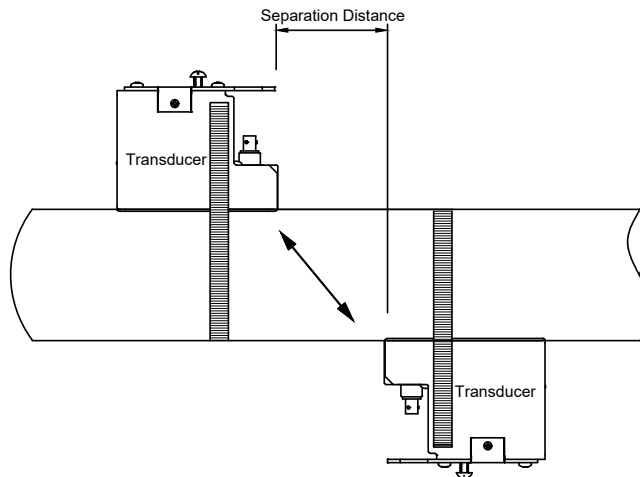

1 CROSS SEPARATION DISTANCE (DIRECT)

\*Shown in "Setup" menu after sensor, fluid and pipe parameters are entered. See pg. 47 for more information.

### 3.2 SITE SELECTION

When selecting a site for mounting the system components, consider the criteria under Section 1.6 WORKING ENVIRONMENT, as well as the following:

#### 3.2.1 The Wall-Mount Enclosure

Find an easily accessible location where wire connections can be made and meter readings can be taken from floor level. Mount the enclosure on a vibration-free surface. Avoid sites such as the plenum of a fan coil, heat exchanger, or other housings containing motors. Avoid mounting the enclosure in close proximity to VFD's, electric motors or other strong sources of electrical interference.



#### IMPORTANT NOTE

**The maximum allowable distance between the wall-mount enclosure and the transducers installed on the pipe is 100 feet. Only ONICON furnished cable may be used between wall-mount enclosure and the transducers.**

### 3.2.2 The Transducers

For best results, the transducers should be installed on a straight run of pipe free of bends, tees, valves, transitions, insertion probes and obstructions of any kind. For most installations, ten straight unobstructed pipe diameters upstream and five diameters downstream of the transducers is the minimum recommended distance for proper operation. Additional considerations are outlined below.

#### **IMPORTANT NOTE**

***In some cases, longer straight runs may be necessary where the transducers are placed downstream from devices which cause unusual flow profile disruptions or swirl (for example, modulating valves, two elbows in close proximity and out of plane, etc.)***

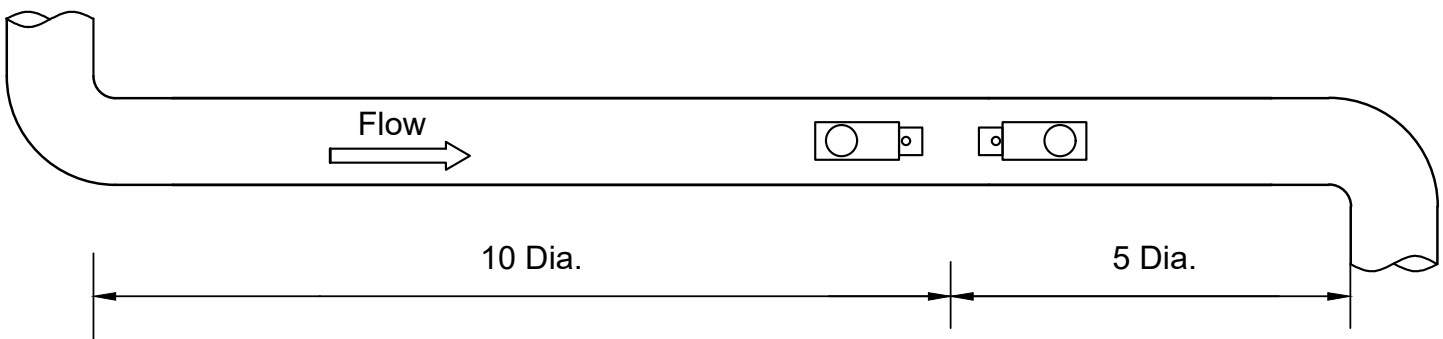

- Avoid installing the transducers downstream from a throttling valve, a mixing tank, the discharge of a positive displacement pump, or any other equipment that could possibly aerate the liquid. The best location will be as free as possible from flow disturbances, vibration, sources of heat, noise, or radiated energy.
- Avoid mounting the transducers on a section of pipe with any external scale. Remove all scale, rust, loose paint, etc., from the location prior to mounting the transducers.
- Do not mount the transducers on a surface aberration (pipe seam, etc.).
- Do not mount transducers from different ultrasonic flow meters on the same pipe.
- Do not run the transducer triaxial cables in common bundles with cables from other instrumentation. You can run these cables through a common conduit ONLY if they originate at the same flow meter.
- Never mount transducers under water.
- Avoid mounting transducers on the top of a horizontal pipe. The best placement on a horizontal pipe is either the 8:00 to 10:00 or 2:00 to 4:00 position for 2 cross (Reflect) or 4 cross (Double Reflect) mode, or one sensor at 9:00 and one sensor at 3:00 for 1 cross mode (Direct).
- Do not mount transducers on the bottom of a horizontal pipe.
- Mounting on a vertical pipe is the recommended installation method if flow is in the upward direction. When mounting on a vertical pipe flowing in a downward direction, make sure there is sufficient back pressure in the system to maintain a full pipe.

3.2.3 Transducer Mounting Recommendations

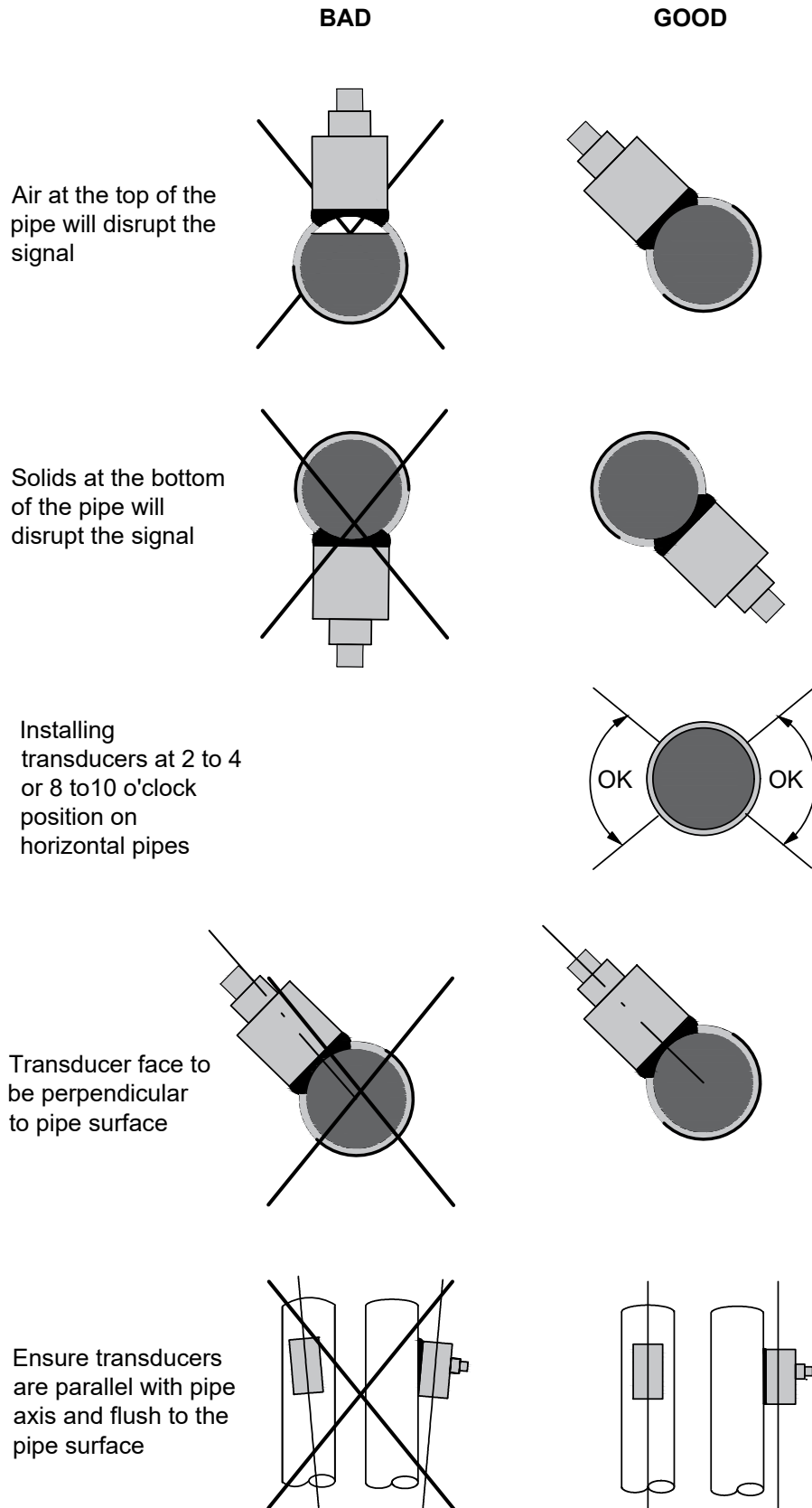

### 3.3 MECHANICAL INSTALLATION

#### 3.3.1 Dimensions

##### 3.3.1.1 Enclosure Dimensions

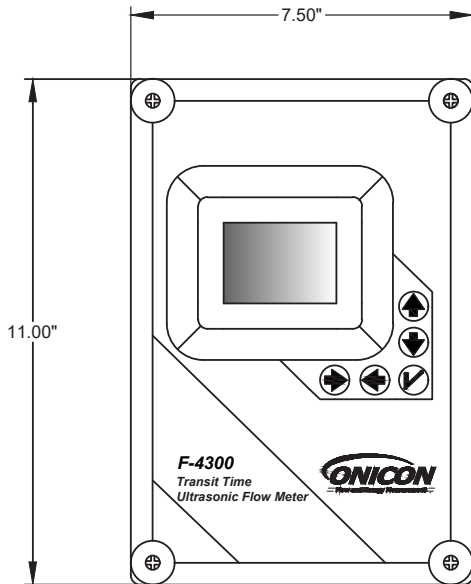

ENCLOSURE DIMENSIONS

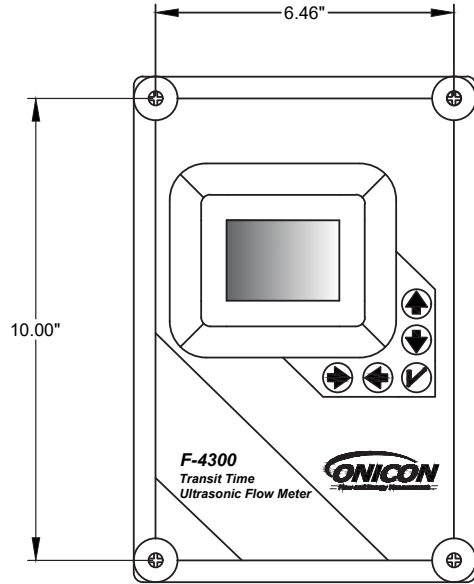

MOUNTING HOLD DIMENSIONS

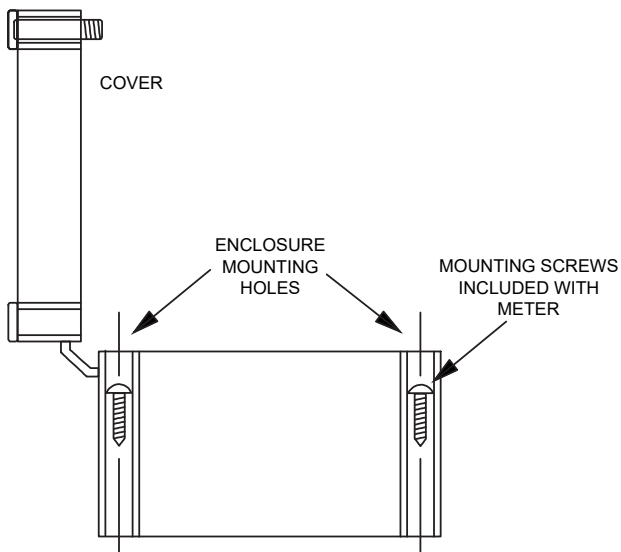

END VIEW

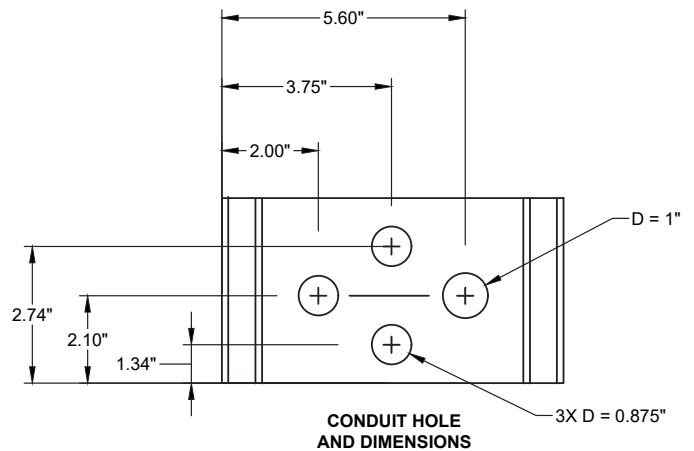

CONDUIT HOLE AND DIMENSIONS

**CAUTION**

**Do not drill additional holes in this enclosure. Doing so may damage the electronic circuitry contained within and will void all warranties.**



3.3.1.2 10 Series Transducer Dimensions

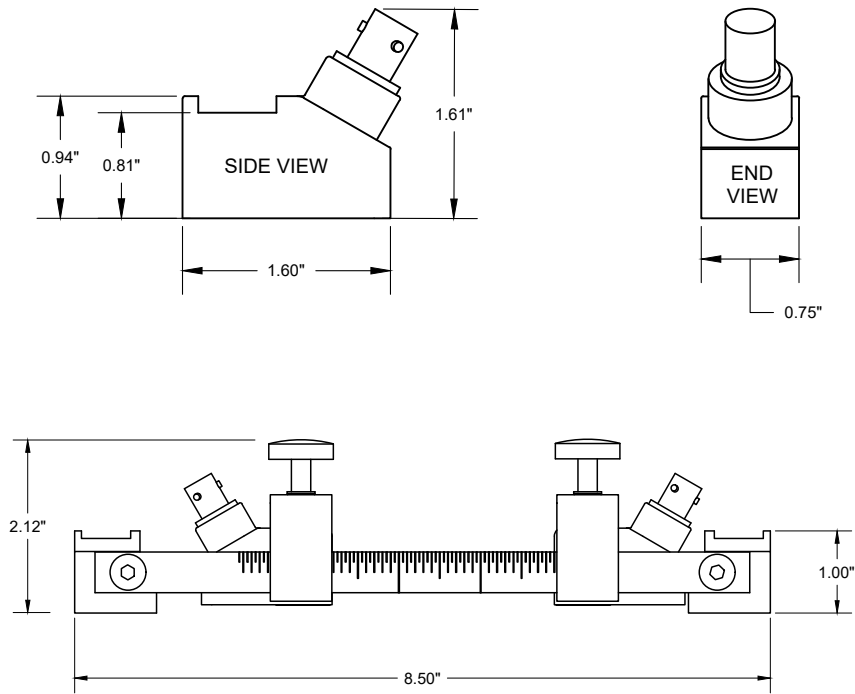

3.3.1.3 20 Series Transducer Dimensions

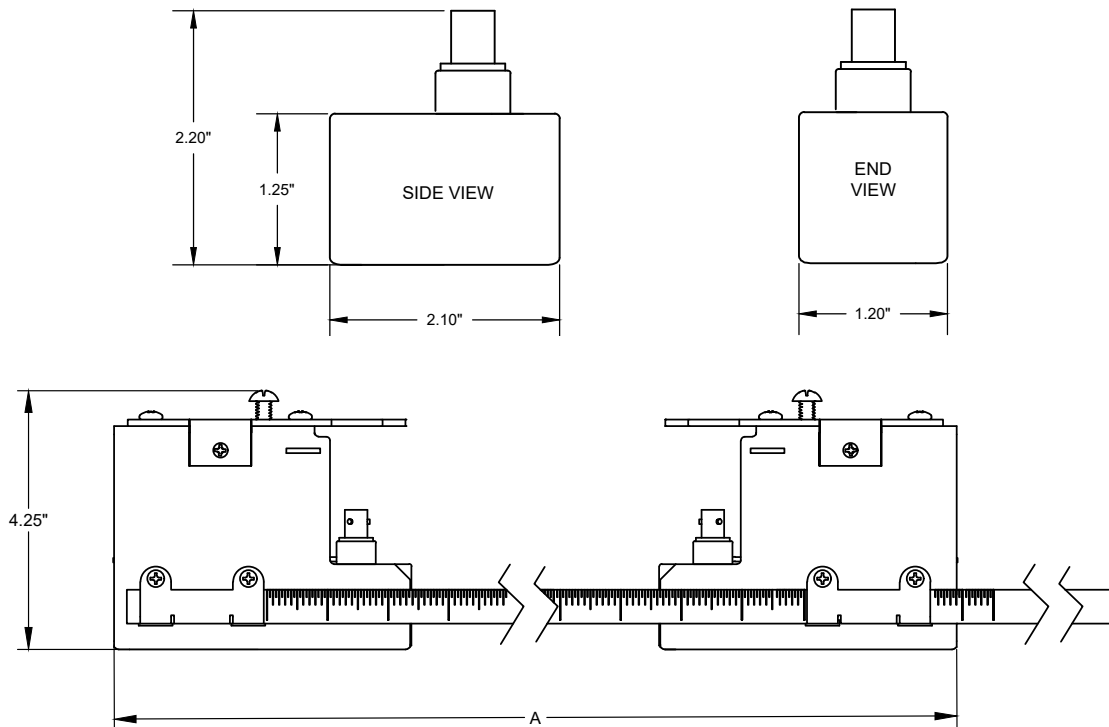

Dimension (A) varies based on pipe material, wall thickness, and shown in "Setup" menu after sensor, fluid and pipe parameters are entered. See pg. 47 for more information.

3.3.1.4 30 Series Transducer Dimensions

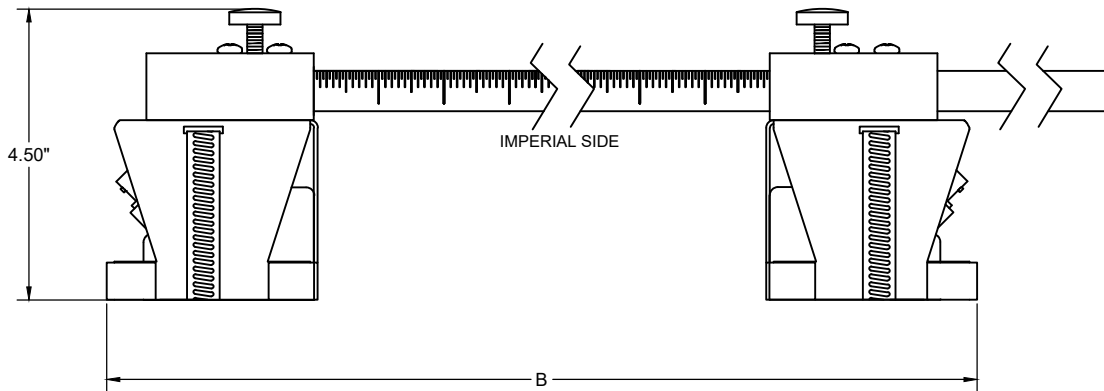
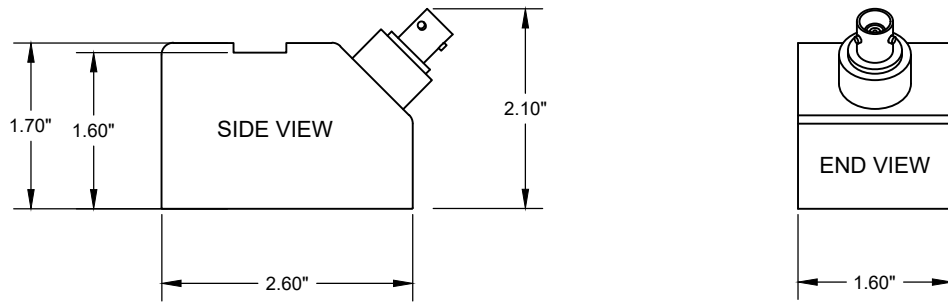

Dimension (B) varies based on pipe material, wall thickness, and shown in "Setup" menu after sensor, fluid and pipe parameters are entered. See pg. 47 for more information.

### 3.3.2 10 Series Mechanical Installation

#### 3.3.2.1 Preparing the Pipe for 10 Series Transducers

Once a suitable section of straight pipe has been located, the pipe surface must be prepared. Refer to the [Site Installation Details](#) document provided with the installation hardware to determine the transducer spacing dimensions.

For the track mount bracket, prepare an area of 2" wide by 10" long by removing loose paint, scale and rust. The objective of site preparation is to eliminate any discontinuity between the sensor and the pipe wall, which would prevent acoustical coupling. A sanding block is included with every meter to facilitate proper pipe preparation.

A mounting kit is supplied with each flow meter. It includes recommended coupling compound and a stainless steel mounting bracket with adjustable pipe straps. Use the alignment and spacer tool to easily measure separation distance between transducer faces.

**IMPORTANT NOTE**

*Always install hardware at the 2:00 to 4:00 or 8:00 to 10:00 position on horizontal pipes. This prevents the flow meter from being affect by air trapped at the top of the pipe.*

**IMPORTANT NOTE**

*The 10 Series transit-time transducers should be installed with the cable connections pointed away from each other, as shown in the drawing below.*

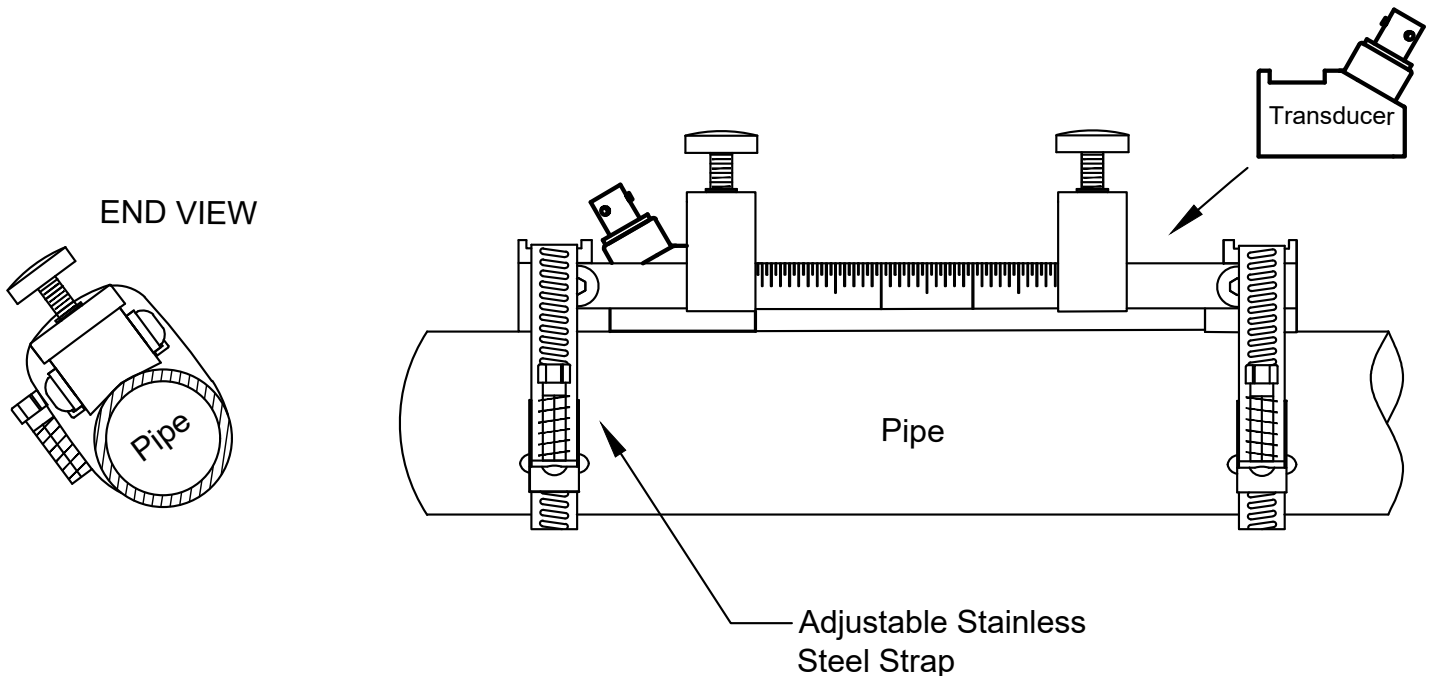

### 3.3.2.2 Two (2) or Four (4) Cross Mounting Installation for 10 Series Transducers

Two (2) or four (4) cross mount is the recommended operating mode whenever possible. It is the simplest way to mount the transducers.

#### Mounting Installation Procedure:

1. Prepare the pipe surface as described in section 3.3.2.1
2. Install the stainless steel mounting track on the pipe. Place the tightening brackets near the center, the transducers will be inserted from the outside.

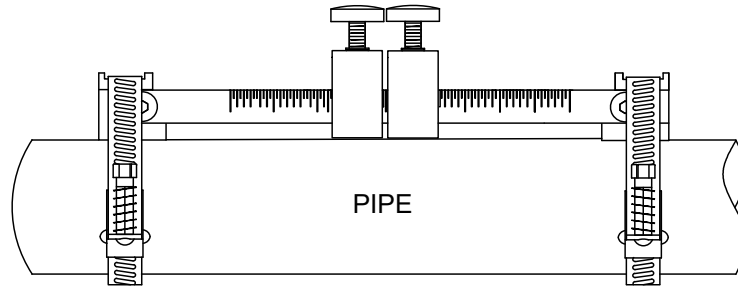

3. Apply a small amount of coupling compound on the first transducer and place this transducer in the reference position. This is the position where the face of the transducer aligns with the 0" mark on the alignment and spacer tool. Tighten this transducer down using the built-in tightening bracket. DO NOT over-tighten the screw.

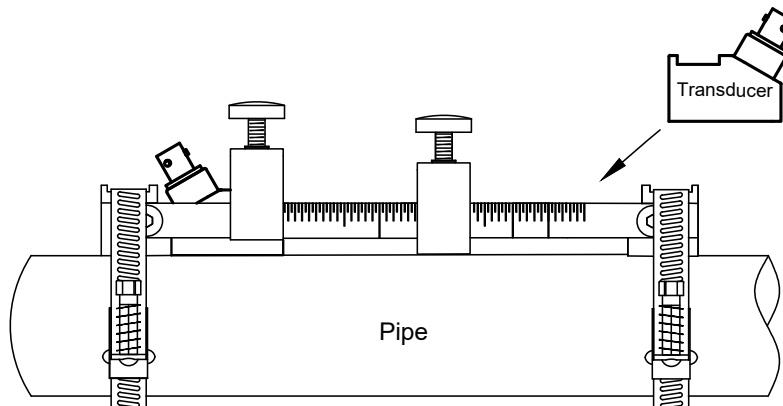
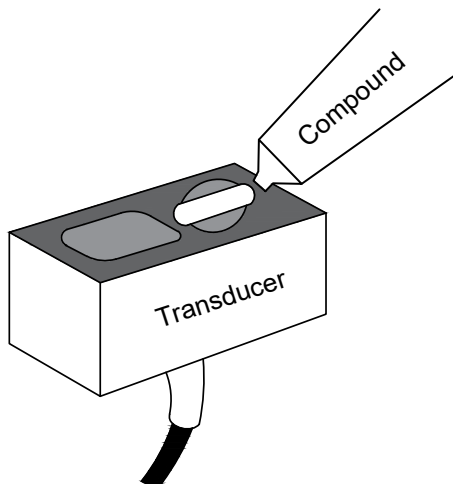

4. Apply a small amount of coupling compound on the second transducer and place this transducer at the separation distance provided in the [Site Installation Details](#) document. Tighten the transducer down using the built-in tightening bracket. DO NOT over-tighten the screw.

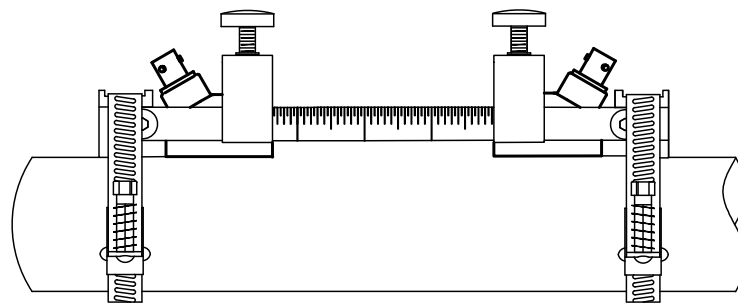

5. Make any fine adjustments ( $\pm 0.1"$ ) to the spacing at this point by loosening the tightening screw slightly, sliding the second transducer, then re-tightening it.

3.3.3 20 Series Mechanical Installation

3.3.3.1 Preparing the Pipe for 20 Series Transducers

Once a suitable section of straight pipe has been located, the pipe surface must be prepared. Refer to the [Site Installation Details](#) document provided with the installation hardware to determine the transducer spacing dimensions.

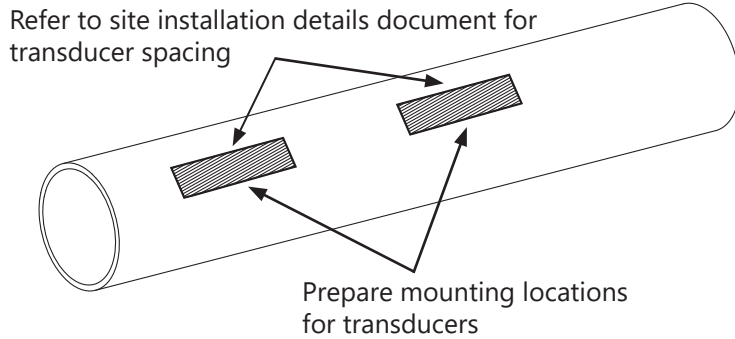

Prepare an area 2" wide by 4" long for each sensor bonding as shown below. Clean and de-grease two rectangles where the transducers will be located. Use the sanding block provided to remove any grit, corrosion, rust, loose paint, or other contaminants. The cleaned surface should extend at least 1/2" beyond the length and width of the transducers.

**IMPORTANT NOTE**

**Always install hardware at the 2:00 to 4:00 or 8:00 to 10:00 position on horizontal pipes. This prevents the flow meter from being affect by air trapped at the top of the pipe.**

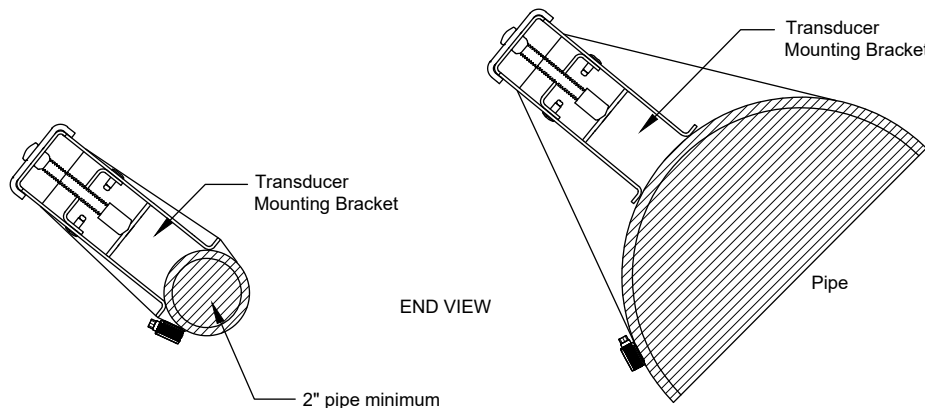
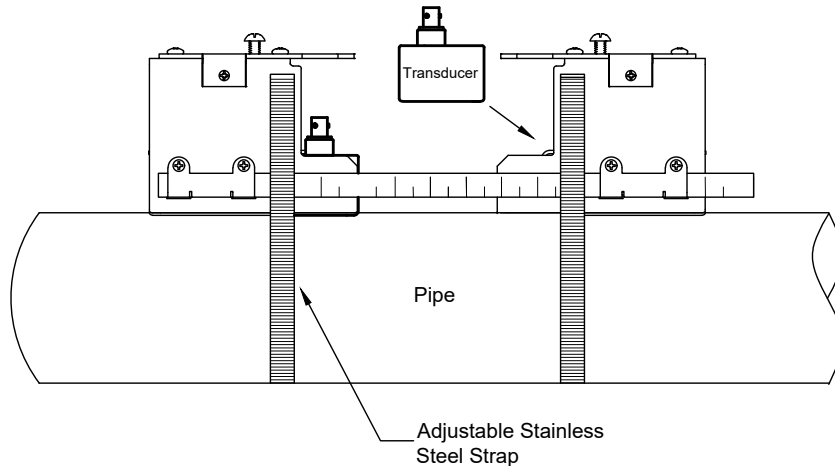

**3.3.3.2 Two (2) or Four (4) Cross Mounting Installation for 20 Series Transducers**

Two (2) or four (4) cross mount is the recommended operating mode whenever possible. It is the simplest way to mount the transducers.

Mounting Installation Procedure:

1. Prepare the pipe surface as described in section 3.3.3.1.
2. On a flat surface, assemble the hardware as shown in the drawing below. Refer to the Site Installation Details document provided with the installation hardware to determine the transducer spacing dimensions.

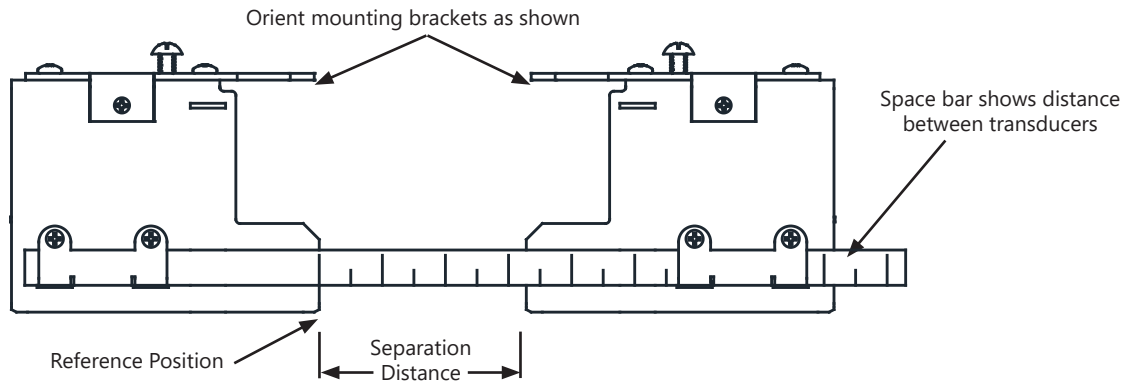

3. Install the mounting straps as shown below. For larger pipes, use multiple straps connected end-to-end to increase the length of each strap. Leave enough slack in the straps to allow the assembly to be correctly positioned on the pipe. The location of the routing hole allows for the straps to mount outside of the pipe insulation if the pipe is insulated.

Wrap the first mounting strap around the pipe and through the holes of the side of the mounting bracket. Make sure to position it so there is easy access to the adjustment screw. Repeat this procedure for the second mounting bracket.

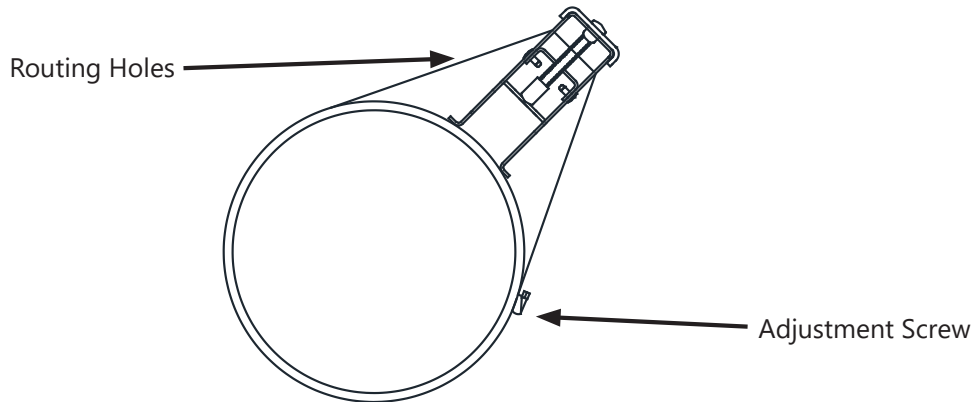

4. Move the hardware assembly to its final position on the pipe. Align the brackets with the prepared surface for each transducer, ensuring that the entire assembly is properly oriented along the axis of the pipe.

3.3.3.2 Two (2) or Four (4) Cross Mounting Installation for 20 Series Transducers (Continued)

5. Apply a small amount of coupling compound to the transducers. A packet of acoustic coupling compound was supplied with the transducers. Contact ONICON if you need more compound.

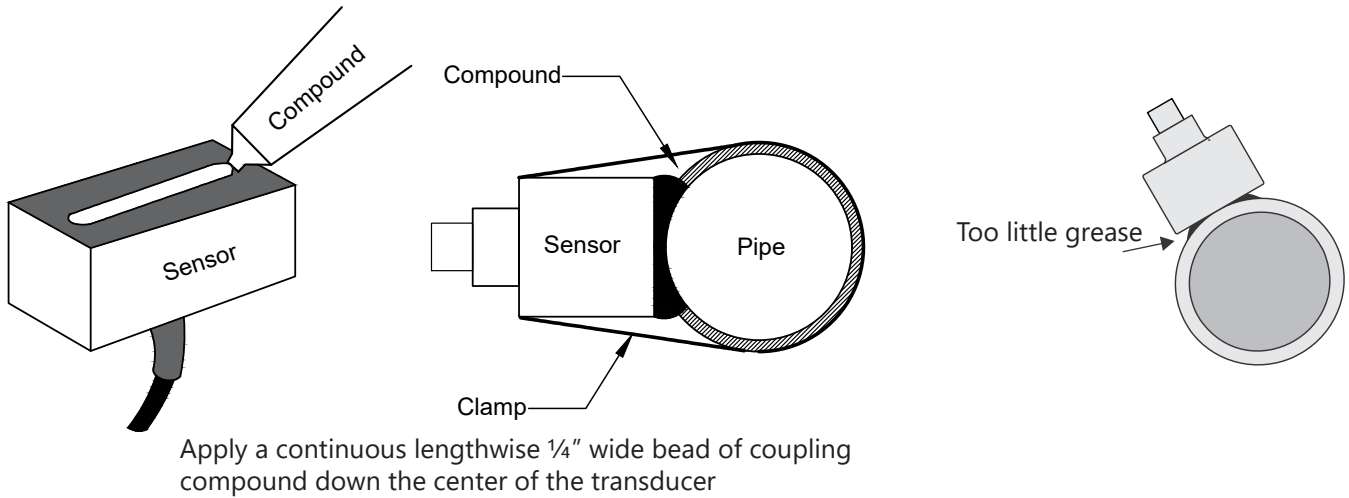

6. Slide the transducer into the mounting bracket. DO NOT allow the bottom of the transducer to contact the pipe until it butts against the mounting bracket. The clamping bracket can be retracted such that the transducer can be directly over the correct position before contacting the pipe. Push down firmly on the transducer to mate with pipe.

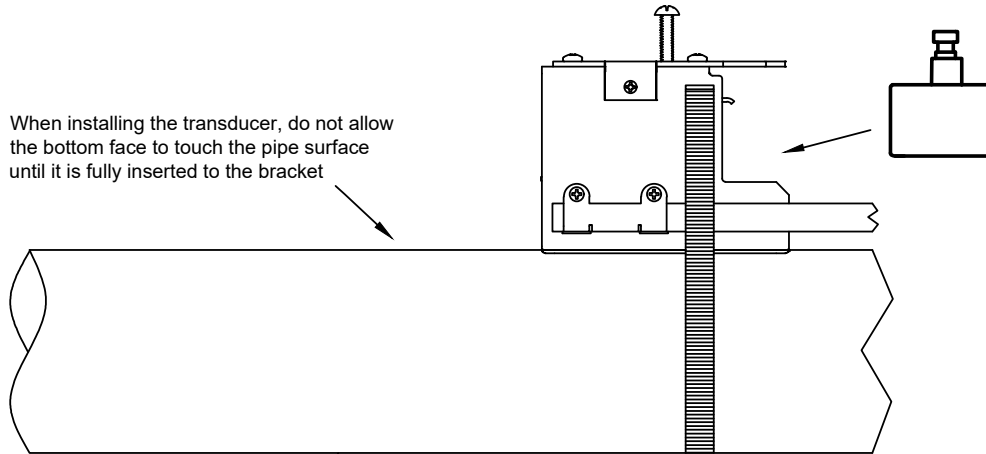

7. Tighten the transducer clamping screw to hold the transducer firmly in place. DO NOT over tighten the screw. If you are not routing flexible conduit all the way to the mounting bracket, you can remove the conduit adapters to make installation easier.

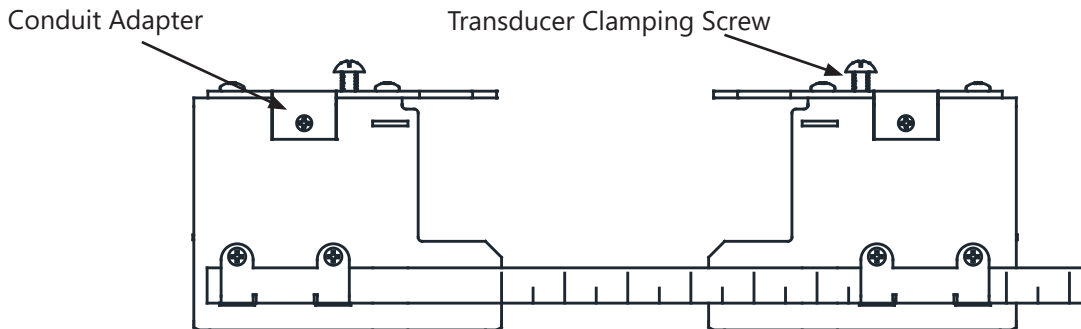

**3.3.3.2 Two (2) or Four (4) Cross Mounting Installation for 20 Series Transducers (Continued)**

8. Make any fine adjustments ( $\pm 0.25''$ ) to the spacing at this point by loosening the tightening screw slightly, sliding the brackets while transducers are installed inside them, then re-tightening the screws when done.

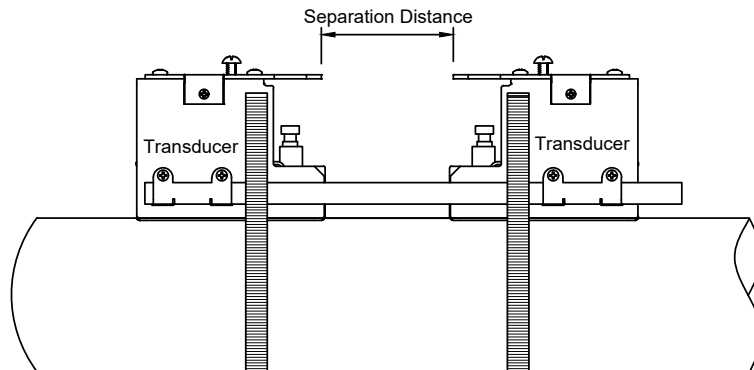

Transducer Installation Procedure:

1. Apply a generous amount of acoustic coupling compound dielectric grease inside the rubber boot.
2. Slide the protective rubber boot over the BNC connector.
3. Repeat procedure for the second transducer.

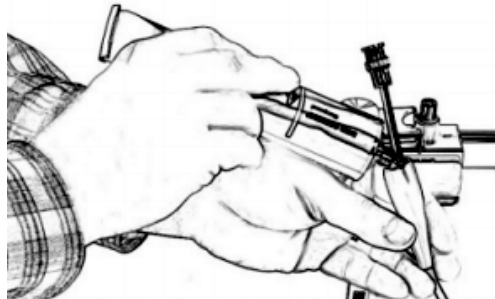



**3.3.3.3 One (1) Cross Mounting Installation for 20 Series Transducer**

One (1) cross mount is recommended when 100% signal strength from two (2) or four (4) cross is not met. Typically, one (1) cross is used for older, large pipes that have built up corrosion within the pipe walls.

Mounting Installation Procedure:

1. Once the installation site selection process described in section 3.2 is complete, prepare the pipe as described in 3.3.3.1.

**IMPORTANT NOTE**

**One (1) cross mode mounting requires that transducers be installed on opposite sides of the pipe. For horizontal pipes, the transducers should be located at the 3 o'clock and 9 o'clock positions.**

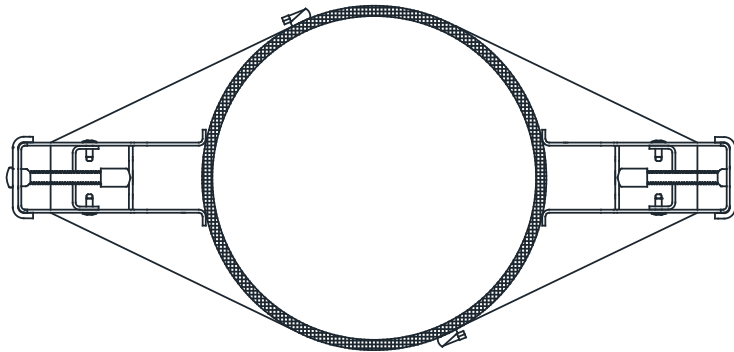

2. Attach the alignment and spacer tool to one of the mounting brackets at the reference mark on the ruler.
3. Position the mounting bracket and an alignment and spacer tool in the center of the cleaned area and secure it in place with a mounting strap. Make sure the mounting strap tightening screw is facing up. While tightening the strap, check to ensure that the bracket remains centered on the pipe.

The bracket is centered on the pipe when the bottom edges of both stainless side plates on the bracket are in full contact with the pipe surface. For horizontal pipe positions, hold the level up to the top of the bracket to ensure the angle is correct.

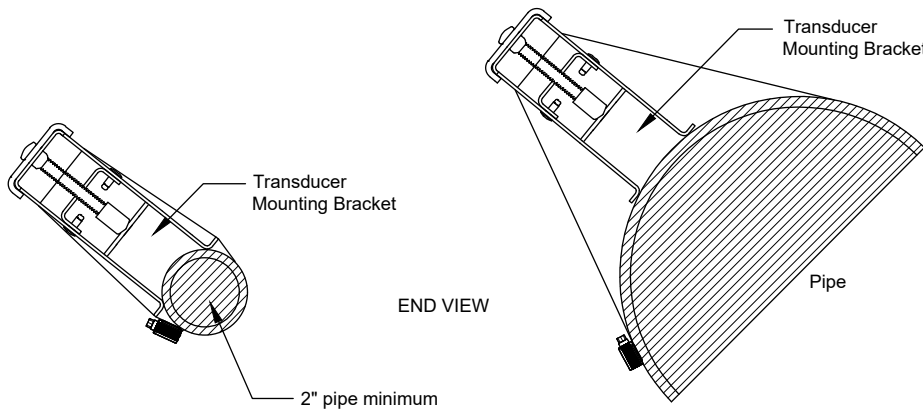

**IMPORTANT NOTE**

**Mount the mounting bracket as illustrated on pipes 2" (50 mm) od or larger. Stainless steel bands are included for mounting on pipes up to 10" (250 mm) nominal pipe size.**

**3.3.3.3 One (1) Cross Mounting Installation for 20 Series Transducer (Continued)**

4. Attach the second bracket to the alignment and spacer tool at the separation distance specified on the Site Installation Details document provided with the installation hardware.

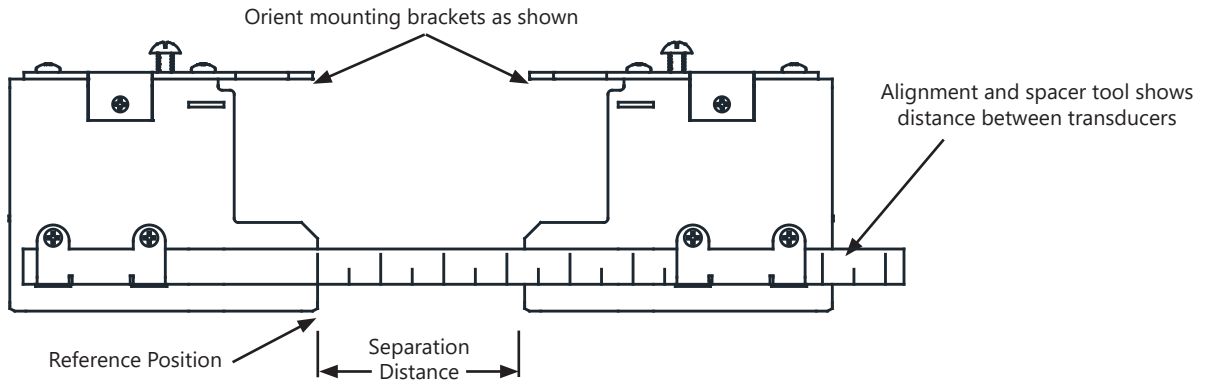

5. Use level to ensure that this bracket is lined up on the center of the pipe. While holding the bracket centered on the pipe, place a mark at the center of the bottom of the bracket then mark along the edge of the bracket as indicated in the drawing below.

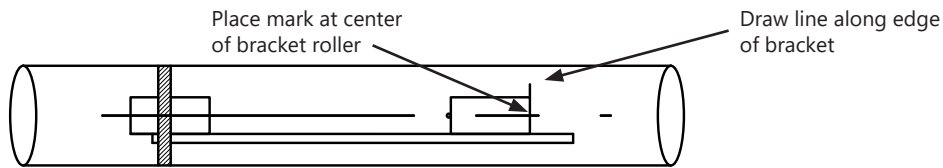

6. Remove the bracket and remove the alignment and spacer tool from the remaining bracket that is strapped to the pipe. Using the alignment and spacer tool as a straight edge, draw a line down the center of the pipe intersecting the mark made at the center of the tapered roller and the line drawn against the edge of the bracket as shown below.

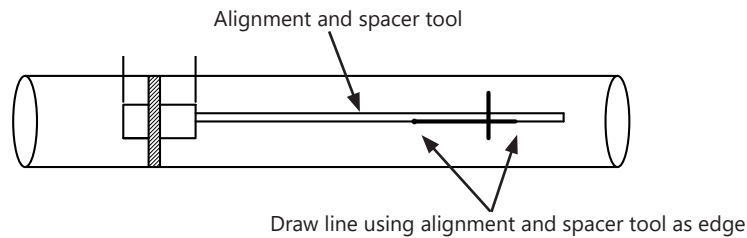

7. Wrap the mylar sleeve around the pipe so that the left edge is against the transducer edge mark. Arrange so that one end overlaps the other. Ensure that it is snug around the pipe and mark along the overlapping edge.

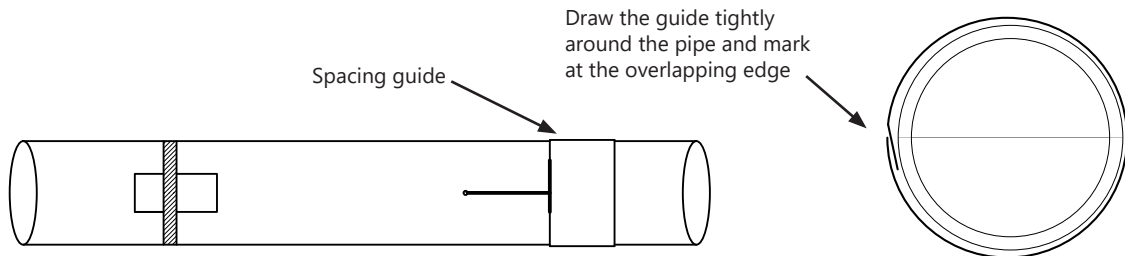

**3.3.3.3 One (1) Cross Mounting Installation for 20 Series Transducer (Continued)**

8. Remove the mylar and lay it out on a flat surface. Either measure the exact distance half-way between the overlap edge and the mark at the overlap or fold the guide from the overlap edge to overlap mark and draw a line at the fold or halfway point.

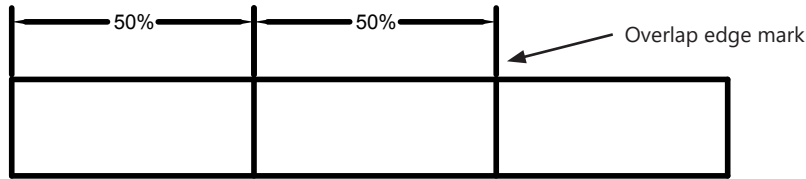

9. Reinstall the mylar; its edge abutting the bracket edge mark on the pipe and the overlapping edge in line with the line drawn down the center of the pipe. Tape it in this position on the pipe. Take the second bracket and place it against the edge of the guide with it centered on the halfway mark drawn on the guide.
10. Ensure that the bracket is sitting on a smooth area without any raised spots (seams, etc.). Mark a generous rectangle around the bracket with a pencil, marker or chalk. Remove the bracket and the spacing guide.
11. Clean and de-grease the area within the rectangle. Use the small sanding block provided with the installation hardware as necessary to remove any grit, corrosion, rust, loose paint or other contaminants. The cleaned surface should extend at least 1/2" beyond the length and width of the mounting bracket.

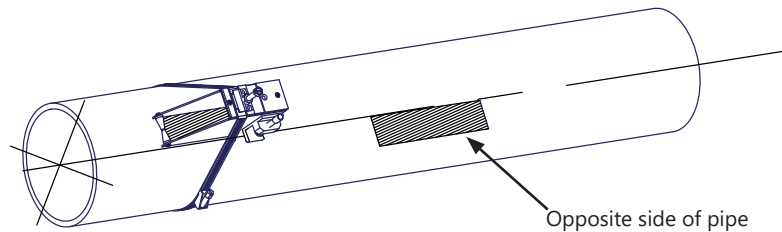

12. Replace the spacing guide back in the same position it was in and re-tape it to the pipe.
13. Position the bracket as before against the edge of the guide with the center of the bracket centered on the halfway mark drawn on the guide. Secure it in place with a mounting strap. Make sure the mounting strap tightening screw is facing toward the bracket so you can hold it in place while tightening the screw. While tightening the strap, check to ensure that the bracket remains centered on the pipe.

The bracket is centered on the pipe when the bottom edges of both stainless steel side plates on the bracket are in full contact with the pipe surface. For horizontal pipe positions, hold the level up to the top of the bracket to ensure the angle is correct.

14. Apply a small amount of coupling compound to the transducers and install them in the brackets. A packet of acoustic coupling compound was supplied with the transducers. Contact ONICON if you need more compound.

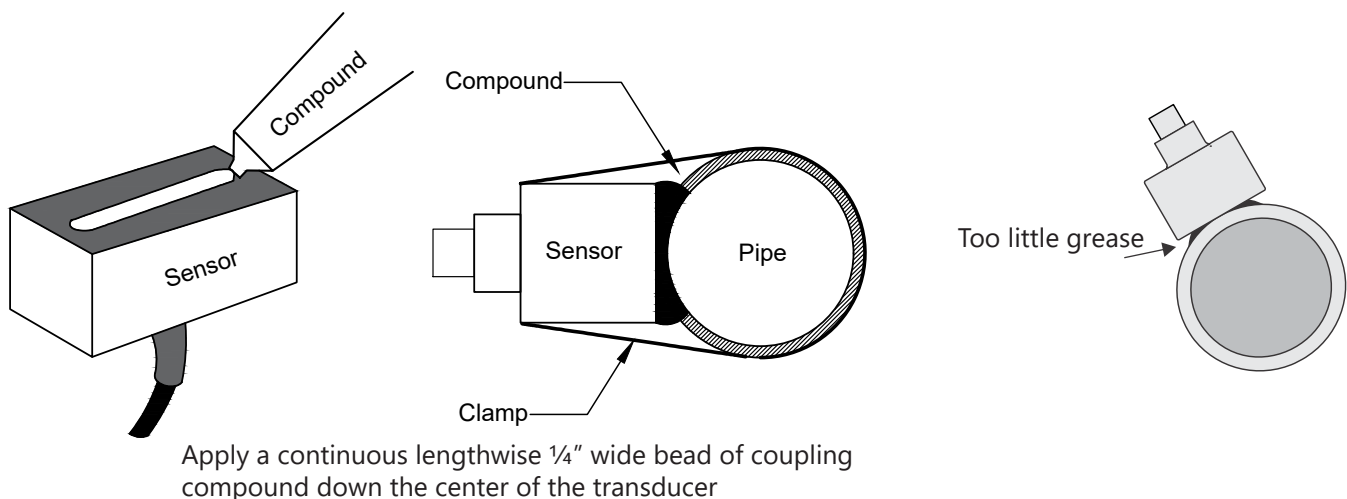

**3.3.3.3 One (1) Cross Mounting Installation for 20 Series Transducer (Continued)**

15. Slide the transducer into the mounting bracket. DO NOT allow the bottom of the transducer to contact the pipe until it butts against the mounting bracket. The clamping bracket can be retracted such that the transducer can be directly over the correct position before contacting the pipe. Push down firmly on the transducer to mate with pipe.

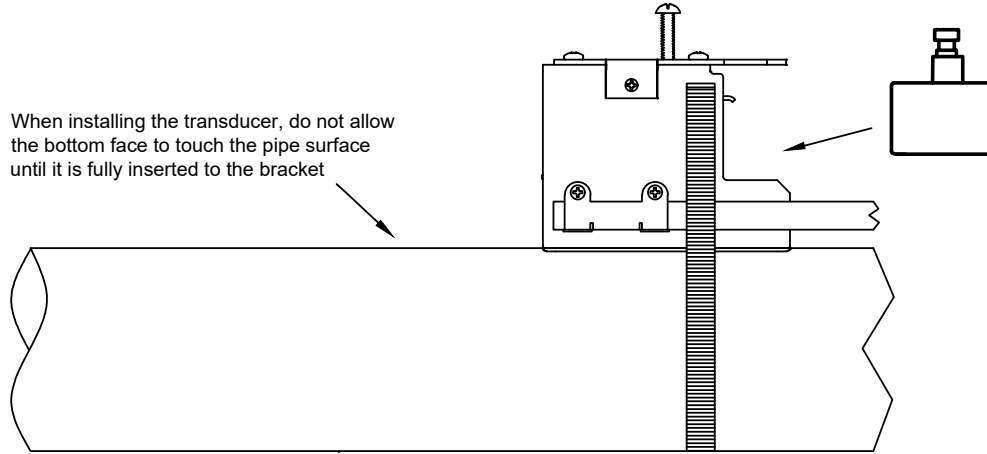

16. Tighten the transducer clamping screw to hold the transducer firmly in place. DO NOT over tighten the screw. If you are not routing flexible conduit all the way to the mounting bracket, you can remove the conduit adapters to make installation easier.
17. Make any fine adjustments ( $\pm 0.25''$ ) to the spacing at this point by loosening the tightening screw slightly, sliding the brackets while transducers are installed inside them, then re-tightening the screws when done.

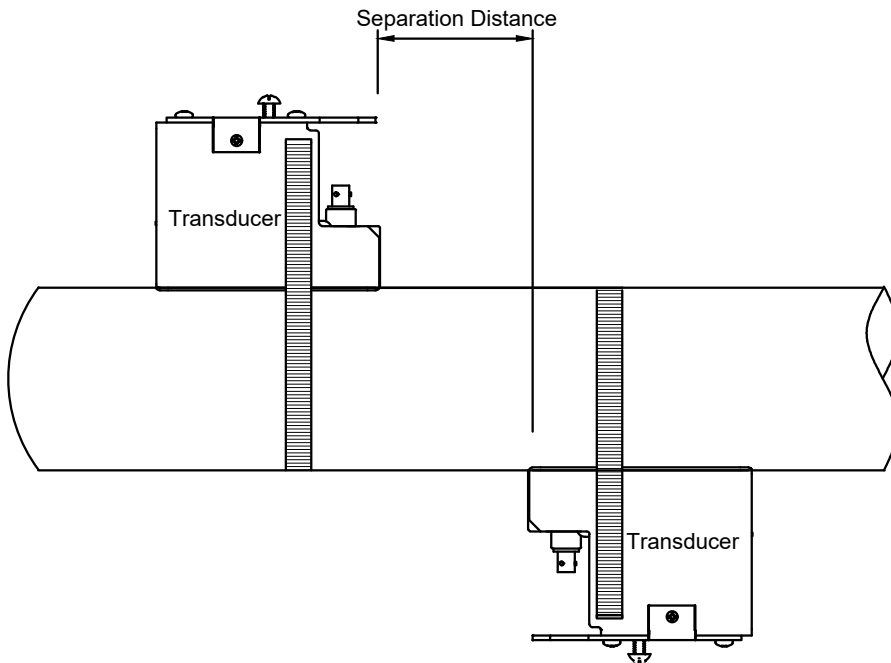

### 3.3.3.3 One (1) Cross Mounting Installation for 20 Series Transducer (Continued)

#### Transducer Installation Procedure:

1. Apply a generous amount of acoustic coupling compound dielectric grease inside the rubber boot.
2. Slide the protective rubber boot over the BNC connector.
3. Repeat procedure for the second transducer.

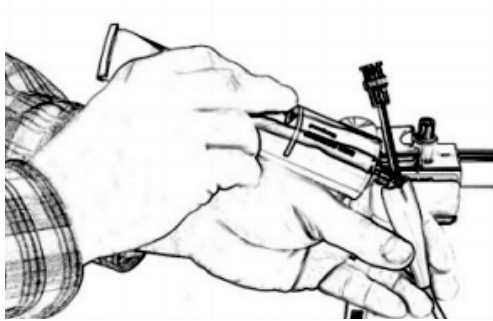

**3.3.4 30 Series Mechanical Installation**

**3.3.4.1 Preparing the Pipe for 30 Series Transducers**

Prepare an area 2" wide by 4" long for each sensor bonding by removing loose paint, scale, and rust. The objective of site preparation is to eliminate any discontinuity between the sensor and the pipe wall, which would prevent acoustical coupling. A sanding block is included with every meter to facilitate proper pipe preparation.

A mounting kit is supplied with each flow meter. It includes recommended coupling compound and a stainless steel mounting bracket with adjustable pipe straps. Use the alignment and spacer tool to easily measure separation distance between transducer faces.

**IMPORTANT NOTE**

**Always install hardware at the 2:00 to 4:00 or 8:00 to 10:00 position on horizontal pipes. This prevents the flow meter from being affect by air trapped at the top of the pipe.**

**IMPORTANT NOTE**

**The 30 Series transit-time transducers should be installed with the cable connections pointed away from each other at installation.**

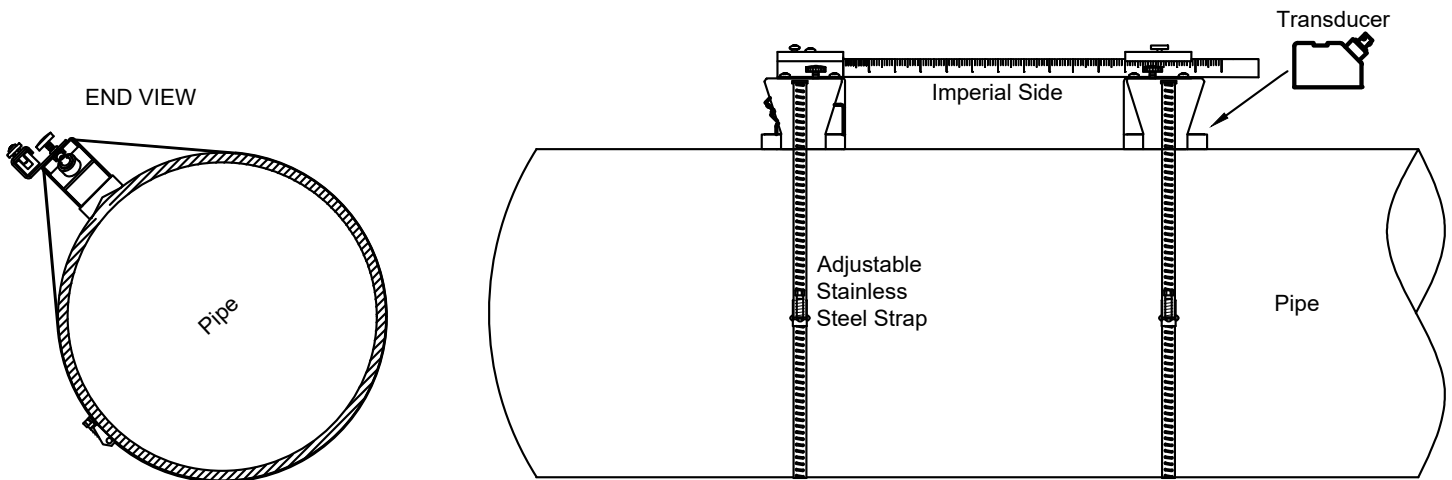

**3.3.4.2 Two (2) Cross Mounting Installation for 30 Series Transducers**

Two (2) cross mount is the recommended operating mode whenever possible. It is the simplest way to mount the transducers.

Mounting Installation Procedure:

1. Prepare the pipe surface as described in section 3.3.4.1.
2. Install the stainless steel mounting brackets on the pipe. Position the brackets at approximately the correct separation distance. Use a 5/16" nut driver to tighten the screws. Exact measurement is not required at this time.
3. Use an alignment and spacer tool to set the bracket spacing to the separation distance provided in the Site Installation Details document. One transducer is placed at the 0" mark, and the other at the separation distance.

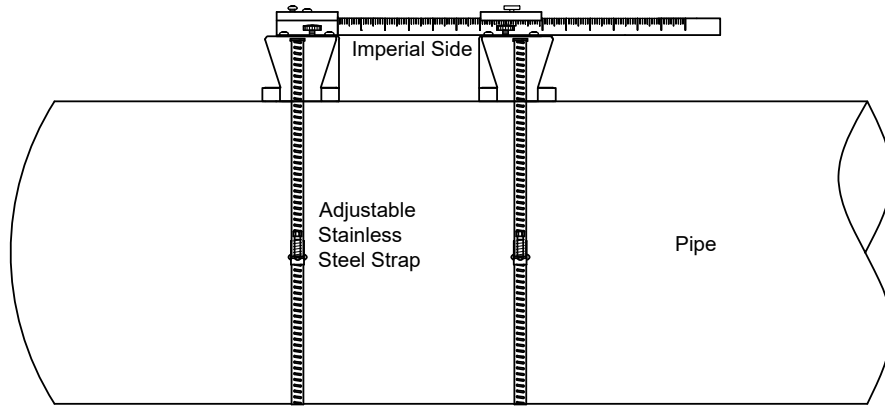

4. Tighten the assembly in place with the tightening screws.
5. Apply a small amount of coupling compound to the transducers. A packet of acoustic coupling compound was supplied with the transducers. Contact ONICON if you need more compound.
6. Insert and tighten the transducers into the brackets. **DO NOT** over-tighten the screw.

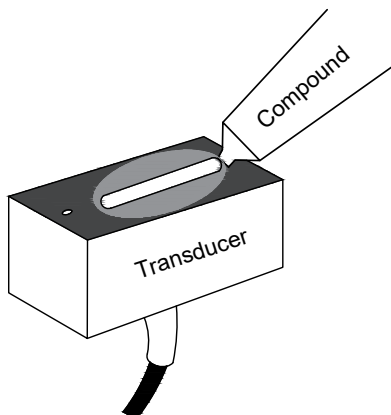

When installing the transducer, do not allow the bottom face to touch the pipe surface until it is fully inserted to the bracket

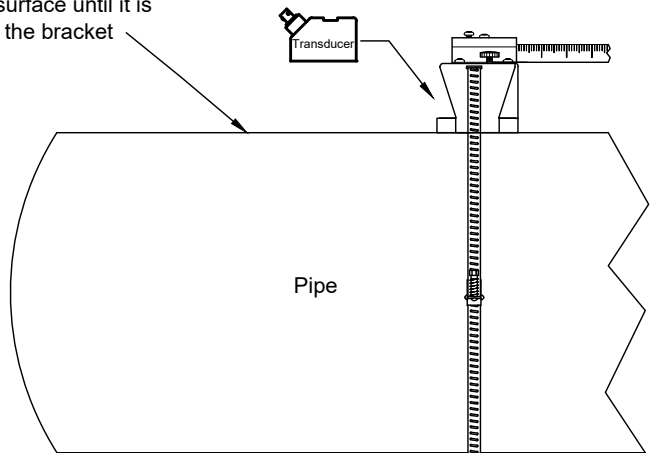

7. Make any fine adjustment ( $\pm 0.25"$ ) to the spacing at this point by loosening the tightening screw slightly, sliding the brackets while the transducer is installed inside, then re-tightening it.

### 3.3.4.2 Two (2) Cross Mounting Installation for 30 Series Transducers (Continued)

Transducer Installation Procedure:

**IMPORTANT NOTE**

**DO NOT remove the transducer's threaded cap until the installation is ready.**

1. Remove the coupling and connect the BNC connector to the transducer.
2. Install the coupling onto the transducer over the connector.
3. Use Teflon tape (not provided) to seal the coupling to the transducer.
4. Loosen the strain relief fitting on the cable.
5. Apply Teflon tape to male threads connecting on strain relief and thread into the coupling.
6. Tighten the strain relief onto the cable.
7. Repeat procedure for the second transducer.

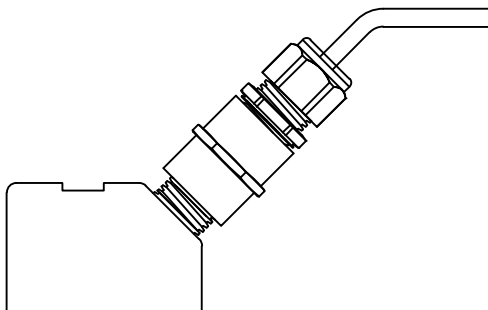

**IMPORTANT NOTE**

**For use with conduit, carefully remove the strain relief fitting from the pre-terminated end of the cable. Connect the 1/2" conduit directly to the transducer.**



**3.3.4.3 One (1) Cross Mounting Installation for 30 Series Transducers**

One (1) cross mount is recommended when 100% signal strength from two (2) cross is not met. Typically, one (1) cross is used for older, large pipes that have built up corrosion within the pipe walls.

Mounting Installation Procedure:

1. Once the installation site selection process described in section 3.2 is complete, prepare the pipe as described in 3.3.3.1.

**IMPORTANT NOTE**

**One (1) cross mode mounting requires that transducers be installed on opposite sides of the pipe. For horizontal pipes, the transducers should be located at the 3 o'clock and 9 o'clock positions.**

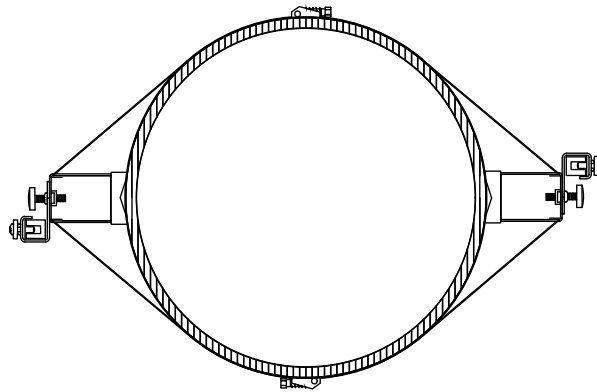

2. Install the stainless steel mounting brackets on the pipe. Position the brackets at approximately the correct separation distance. Use a 5/16" nut driver to tighten the screws. Exact measurement is not required at this time.
3. Use an alignment and spacer tool to set the bracket spacing to the separation distance provided in the Site Installation Details document. One transducer is placed at the 0" mark, and the other at the separation distance.
4. Tighten the assembly in place with the tightening screws. For horizontal pipe positions, hold the level up to the top of the bracket to ensure the angle is correct.

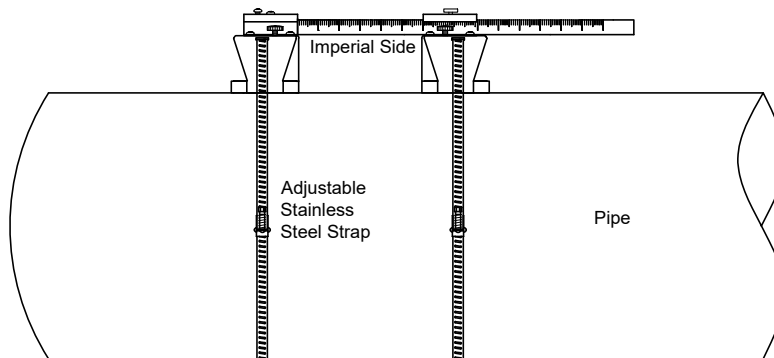

3.3.4.3 One (1) Cross Mounting Installation for 30 Series Transducers (Continued)

- Use level to ensure that this bracket is lined up on the center of the pipe. While holding the bracket centered on the pipe, place a mark at the center of the bottom of the bracket as shown below. Next, mark along the edge of the bracket as indicated in the drawing below.

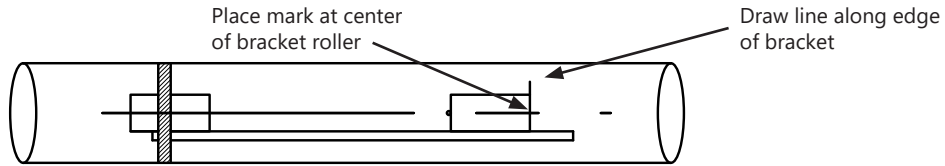

- Remove the bracket from the alignment and spacer tool and then remove the alignment and spacer tool from the remaining bracket that is strapped to the pipe. Using the alignment and spacer tool as a straight edge, draw a line down the center of the pipe intersecting the mark made at the center of the tapered roller and the line drawn against the edge of the bracket as shown below.

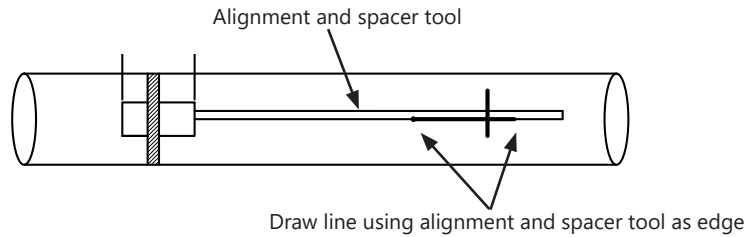

- Wrap the mylar sleeve around the pipe so that the left edge is against the transducer edge mark. Arrange so that one end overlaps the other. Ensure that it is snug around the pipe and mark along the overlapping edge.

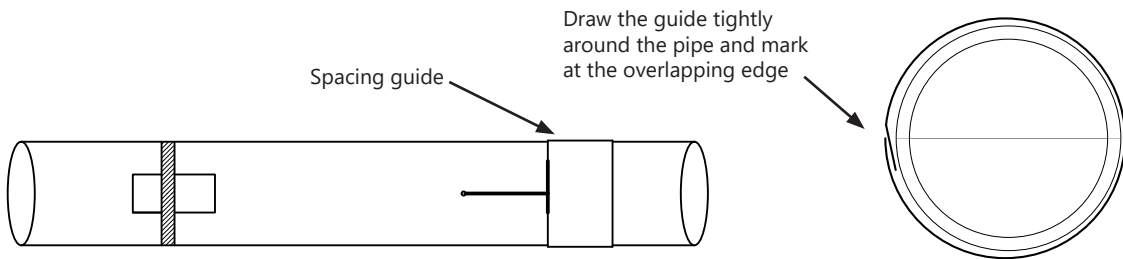

- Remove the mylar and lay it out on a flat surface. Either measure the exact distance half-way between the overlap edge and the mark at the overlap or fold the guide from the overlap edge to overlap mark and draw a line at the fold or halfway point.

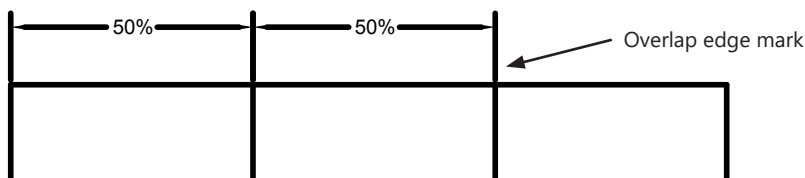

**3.3.4.3 One (1) Cross Mounting Installation for 30 Series Transducers (Continued)**

9. Reinstall the mylar; its edge abutting the bracket edge mark on the pipe and the overlapping edge in line with the line drawn down the center of the pipe. Tape it in this position on the pipe. Take the second bracket and place it against the edge of the guide with it centered on the halfway mark drawn on the guide.
10. Ensure that the bracket is sitting on a smooth area without any raised spots (seams, etc.). Mark a generous rectangle around the bracket with a pencil, marker, or chalk. Remove the bracket and the spacing guide.
11. Clean and de-grease the area within the rectangle. Use the small sanding block provided with the installation hardware as necessary to remove any grit, corrosion, rust, loose paint, or other contaminants. The cleaned surface should extend at least 1/2" beyond the length and width of the mounting bracket.

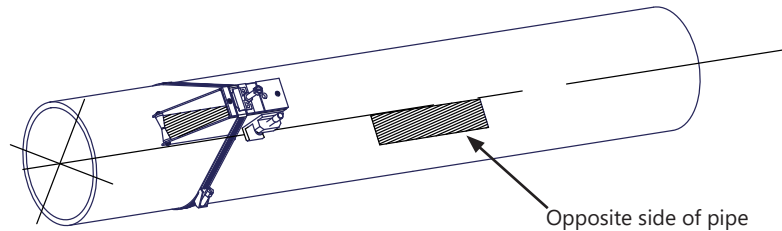

12. Replace the spacing guide back in the same position it was in and re-tape it to the pipe.
13. Position the bracket as before against the edge of the guide with the center of the bracket centered on the halfway mark drawn on the guide. Secure it in place with a mounting strap. Make sure the mounting strap tightening screw is facing toward the bracket so you can hold it in place while tightening the screw. While tightening the strap, check to ensure that the bracket remains centered on the pipe.

The bracket is centered on the pipe when the bottom edges of both stainless steel side plates on the bracket are in full contact with the pipe surface. For horizontal pipe positions, hold the level up to the top of the bracket to ensure the angle is correct.

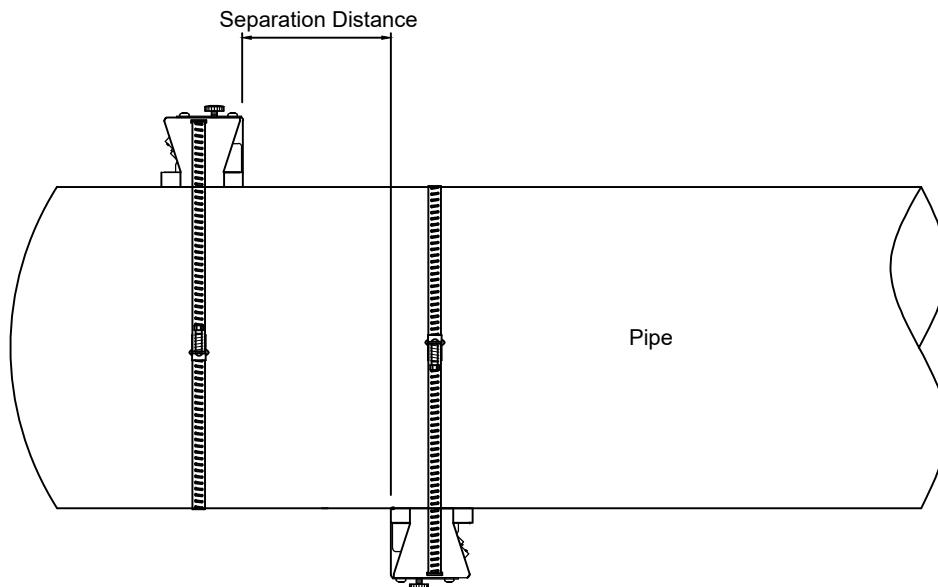

**3.3.4.3 One (1) Cross Mounting Installation for 30 Series Transducers (Continued)**

14. Apply a small amount of coupling compound to the transducers. A packet of acoustic coupling compound was supplied with the transducers. Contact ONICON if you need more compound.
15. Insert and tighten the transducers into the brackets. DO NOT over-tighten the screw.

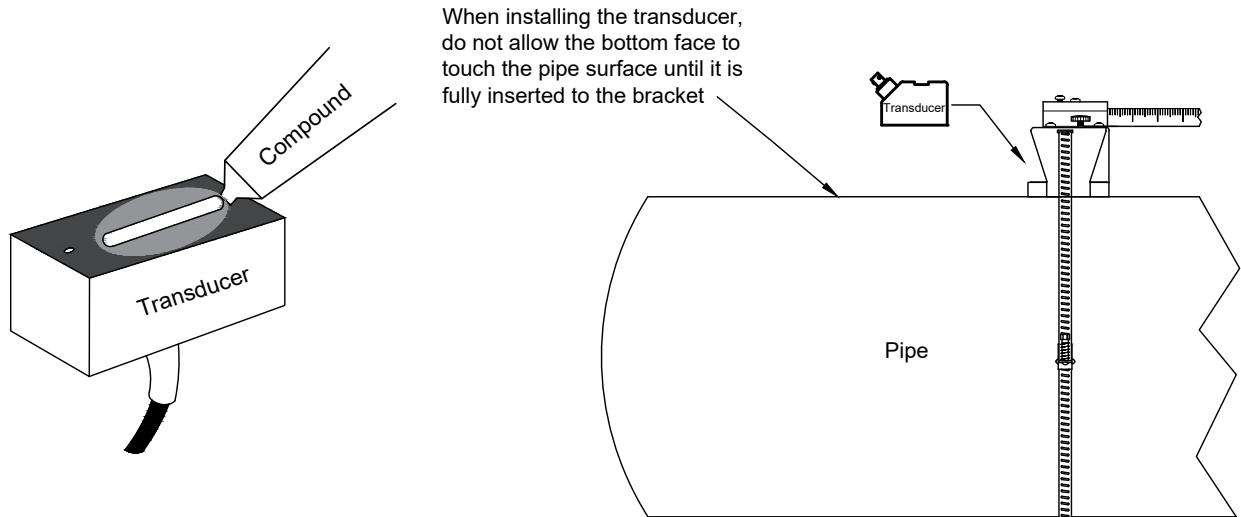

16. Make any fine adjustment ( $\pm 0.25''$ ) to the spacing at this point by loosening the tightening screw slightly, sliding the brackets while the transducer is installed inside, then re-tightening it.

Transducer Installation Procedure:

**IMPORTANT NOTE**

**DO NOT remove the transducer's threaded cap until the installation is ready.**

1. Remove the coupling and connect the BNC connector to the transducer.
2. Install the coupling onto the transducer over the connector.
3. Use Teflon tape (not provided) to seal the coupling to the transducer.
4. Loosen the strain relief fitting on the cable.
5. Apply Teflon tape to male threads connecting on strain relief and thread into the coupling.
6. Tighten the strain relief onto the cable.
7. Repeat procedure for the second transducer.

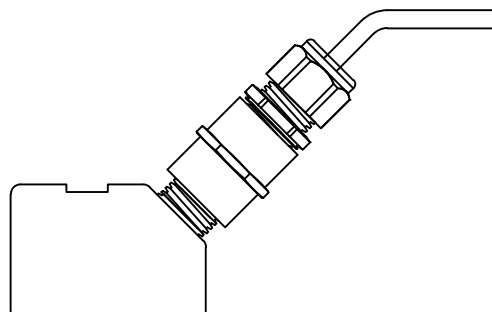

**IMPORTANT NOTE**

**For use with conduit, carefully remove the strain relief fitting from the pre-terminated end of the cable. Connect the 1/2" conduit directly to the transducer.**

### 3.4 CONNECTING THE TRANSDUCER SIGNAL CABLES

ONICON F-4300 transducer cables are special purpose triaxial cables. Care must be taken when installing the cables to ensure that electrical noise will not affect the performance of the meter. The cables must NOT be bundled or run in conduit with any other signal or power cables. The maximum allowable cable length is 100 ft.

1. To install the cables, first locate and install the wall-mount electronics enclosure and the transducers, as described in Section 3.3.

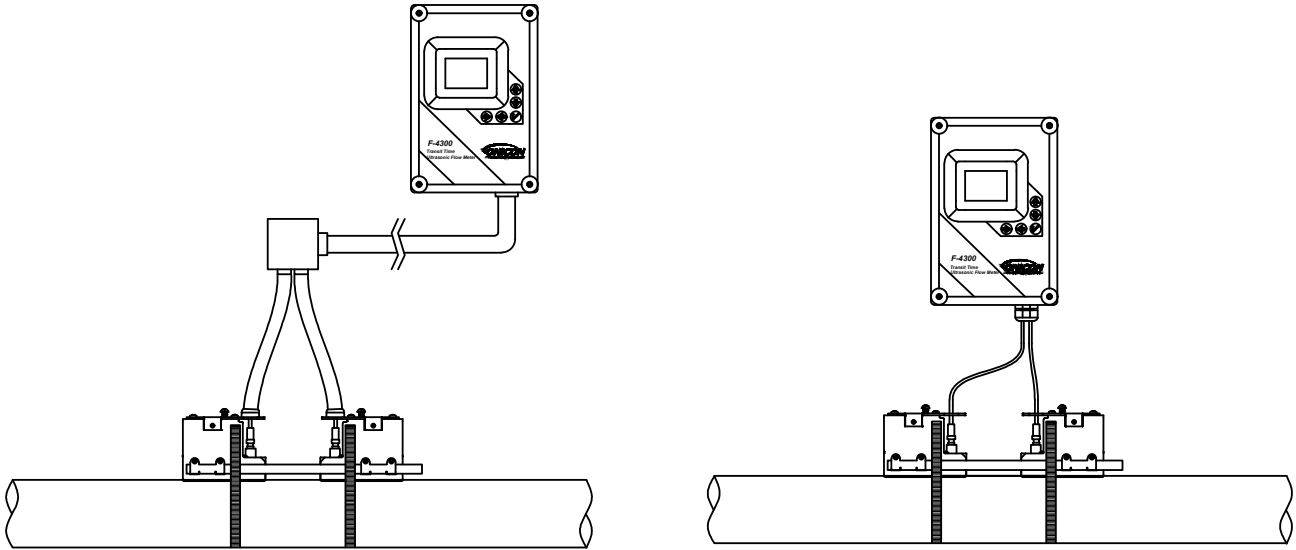

2. The transducer cables are provided with BNC connectors already installed at one end of the cable. Install this end of each cable at the transducers.

**IMPORTANT NOTE**

*If using conduit, route cables from transducer through conduit to electronics enclosure.*

**WARNING**

*For proper operation, cables must not be bundled or run in conduit with any other signal or power cables. Do not cut or splice cables.*

**IMPORTANT NOTE**

*Route the upstream terminal to the upstream transducer located in the terminal block. Repeat for the downstream terminal. If cables are discovered to be backwards after installation, simply reverse the cable installation inside the enclosure.*

3. At the enclosure, the transducer cable should be landed as shown in the image to the left.

### 3.5 ELECTRICAL INSTALLATION

All user supplied conduit fittings, junction boxes, etc. must be installed in compliance with federal, state and local building codes.

#### 3.5.1 Input Power Requirements

The F-4300 can be ordered with two different input voltage options. The input power options are:

24 V AC/DC, 50/60 Hz, 10 VA max

110-240 VAC, 50/60 Hz, 10 VA max

#### **WARNING**

***Conduit openings in the F-4300 enclosure must be closed with UL listed fittings applicable to NEMA 4X enclosures.***

#### **WARNING**

***The protective earth connection must be made as shown in Section 3.5.2. Failure to do so will result in an increased risk of injury.***

#### **WARNING**

***All mains voltage connections must be made through the pre-drilled conduit/strain relief opening located at the bottom of the enclosure. Failure to do so will result in an increased risk of injury.***

#### **CAUTION**

***This product must be connected to earth ground for proper operation. Failure to do so may result in erratic operation.***

3.5.2 Power and Output Signal Wiring Details

**WARNING**

Turn off mains power at the source prior to making power connections to the F-4300. Contact with exposed live wiring may result in electric shock, burns and/or serious injury.

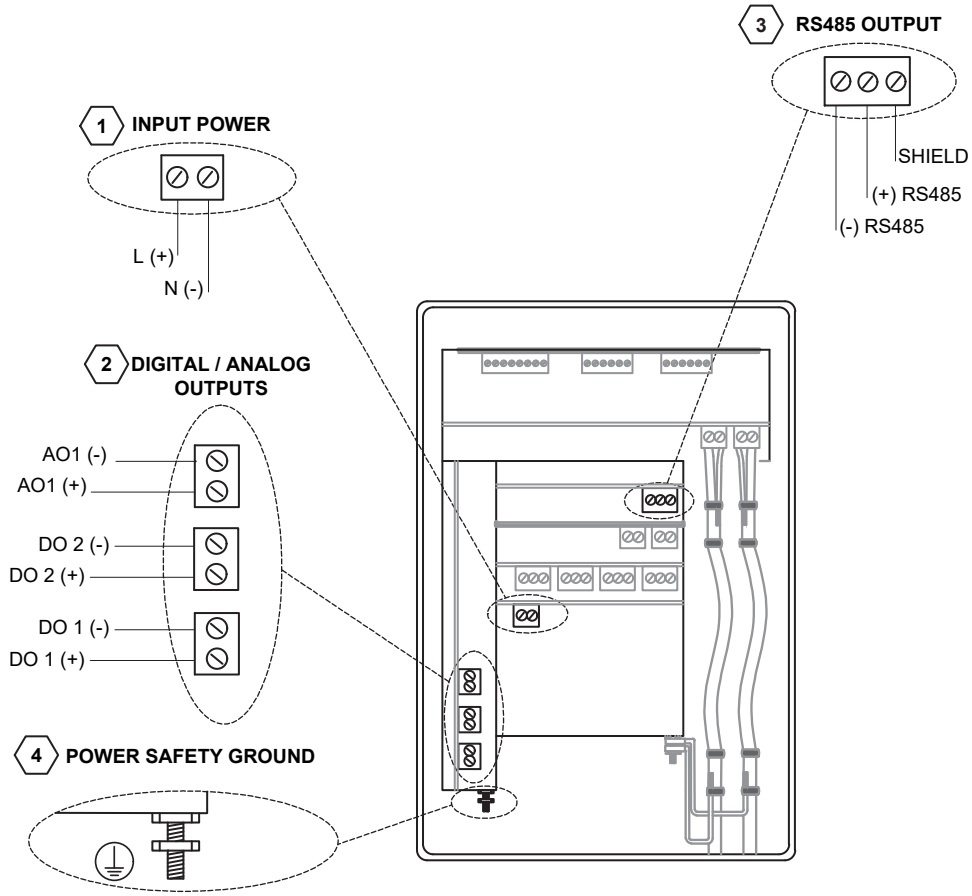

1. Input power  
24 VAC/ VDC, 10 VA max OR  
110-240 VAC, 50/ 60 Hz, 10 VA max
2. RS485 BACnet MS/TP or MODBUS RTU
3. Output configuration  
Two (2) pulse outputs and one (1) active analog output (4-20 mA or 0-5VDC- Menu selectable)

3.5.3 Transducer and Sensor Wiring Details

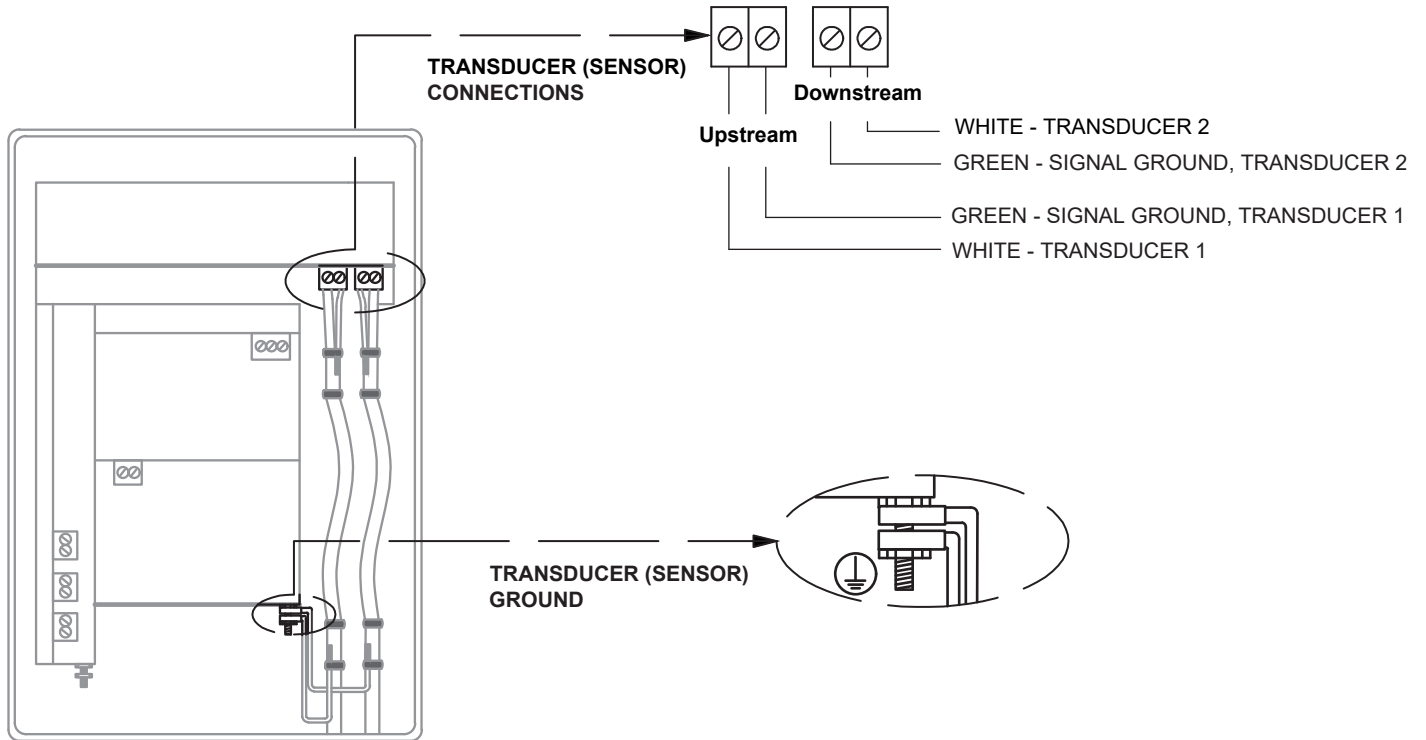

1. Transducer (triaxial) cables must not be bundled or run in conduit with any other signal or power cables
2. When using conduit, run transducer cables from transducers through conduit into electronics enclosure. DO NOT cut or splice triaxial cable termination



## SECTION 4.0 START-UP

ONICON F-4300 Clamp-on Ultrasonic Flow Meters are normally shipped with the intended installation parameters pre-programmed into the memory of the meter. This pre-programmed site is based on installation data provided to ONICON when the meter was ordered. The information programmed into the meter is also provided in a document that accompanies the installation hardware titled Site Installation Details.

Confirm that the Site Installation Details document matches the specific installation location. If there is any discrepancy between programmed parameters and actual site conditions, then the programming for the site must be edited before it is used. This manual contains information on programming the meter in the field, but if you require any assistance, please contact ONICON.

### 4.1 NAVIGATING THE RUN MODE & PROGRAMMING PAGES

The diagram on the next page shows the F-4300 menu system. Arrows show the four directions to navigate between menu boxes. Pressing a corresponding keypad arrow will move to the next item in the direction shown.

Move the cursor (highlighted) under numerals with the ← and → keys.

Increase or decrease numerals with the ↑ and ↓ keys.

Programming values are stored permanently after pressing the ✓.



Run Mode View



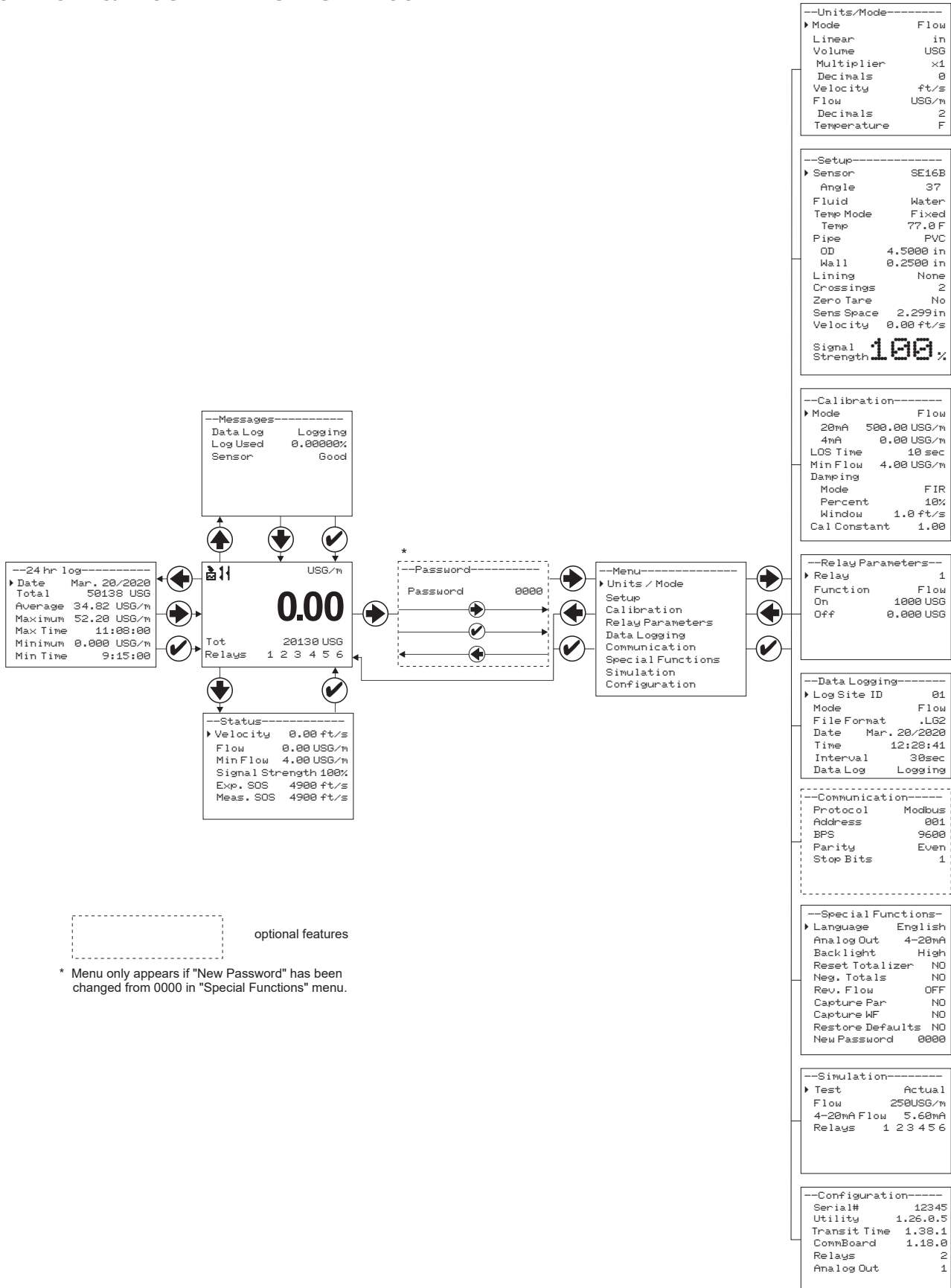













4.2 RUN MODE & PROGRAMMING PAGE LAYOUT



optional features

\* Menu only appears if "New Password" has been changed from 0000 in "Special Functions" menu.

4.3 RUN MODE ICONS

| ICONS   | DESCRIPTION   |
|---|---|
|  1.  2.   | Message waiting. Press  to view message. |
|    | Data logging off.   |
|  1.  2.   | Data logging on.  |
|  1.  2.  3.  4. | USB file download.  |
|    | File download complete.   |
|    | Download error.   |
|  1.  2.  3.   | Ultrasonic echo established.  |
|    | No echo, empty pipe.  |
|    | No sensors attached / wrong settings.   |

4.4 RUN MODE PAGES

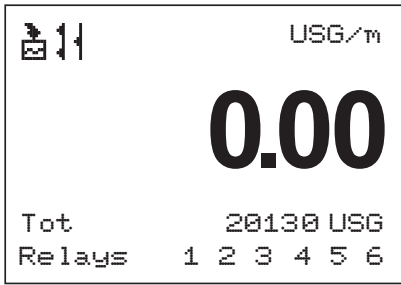

**Main Display Page** - The MAIN display shows the flow rate and totalizer in the units selected via the programming menu. You will see velocity instead of flow rate if you selected the velocity operating mode in the programming menu.

The bottom of the MAIN display shows the status of the pulse outputs. If any of the meter's pulse outputs are configured for volume totalization, the background of the specific pulse output programmed for this totalization will turn black, and then back to white after the pulse duration. If set for flow alarm, the background of the specific pulse output set for this alarm will turn black when latched on, and back to white when latched off.

The top-left corner of the MAIN display shows the status icons. Refer to the previous page for their descriptions.

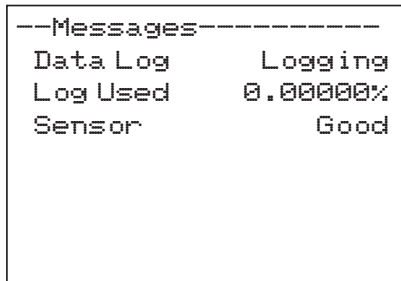

**Message Display Page** - Pressing  from the MAIN display will navigate you to the MESSAGE page. On this page you can find the status of the logger, % log used, sensor status, and temperatures measured by both the upstream and downstream transducers.

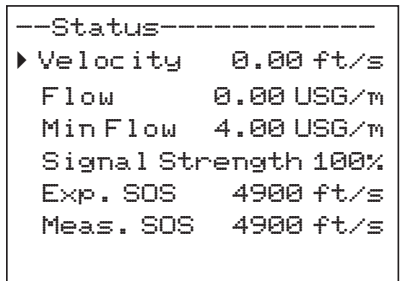

**Status Display Page** - Pressing  from the MAIN display will navigate you to the STATUS page. On this page you can see the flow velocity in units programmed in the meter, signal strength, and relay status again.

Signal strength is an important diagnostic tool. The value can be anywhere between 0-100%. 100% indicates that the meter is successfully transmitting between the upstream and downstream transducers.

If you have no flow, erratic flow, or inaccurate flow, this signal strength number should be noted. You will need to check transducer installation, pipe type and dimensions, and meter programming to resolve these potential issues.

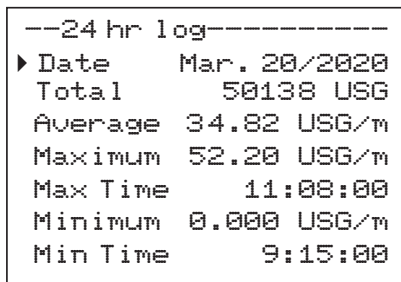

**24 Hour Log Display Page** - Pressing  from the MAIN display will navigate you to the 24 HOUR LOG display. By pressing the down arrow, you can view total flow, average flow, maximum flow, time maximum flow occurred, minimum flow, and time minimum flow occurred for any day after the meter has been deployed. Up to 365 days are stored, and after that date, the oldest data is removed to make room for the newest.

4.4 RUN MODE PAGES (Continued)

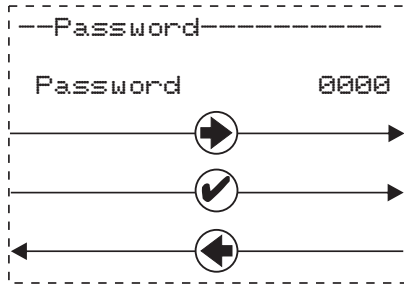

**Password Display Page** - Pressing the ➡ from the MAIN display navigates you to the password entry page if the password has been changed from the default of 0000. This page comes directly before the programming menu, and is meant to allow you the ability to prevent malicious programming changes after deployment.

The password can be changed at any time by navigating into the programming menu and changing it. See section 4.5 for instructions on changing this value. If the password has been changed from the default, use the directional buttons to change the digit values, then the ✓ to accept the password and move into the programming menu.

**4.5 PROGRAMMING MENU PAGES**

Any changes made in these menus are automatically saved and take effect immediately. Your meter should have arrived pre-programmed by ONICON, so please use caution when changing any parameters which affect the setup of the meter, such as the pipe material or pipe size.

For list selection options, press the **➡** at any option to select it, and the **⬆** or **⬇** to change the selection. Press **✓** to accept the change. For numeric entry options, press the **➡** to enter it, **➡** and **⬅** to navigate to different values, and then **⬆** or **⬇** to change the value selected. Press **✓** to accept the change.

| --Units/Mode----- |       |
|-------------------|-------|
| ▶ Mode            | Flow  |
| Linear            | in    |
| Volume            | USG   |
| Multiplier        | x1    |
| Decimals          | 0     |
| Velocity          | ft/s  |
| Flow              | USG/m |
| Decimals          | 2     |
| Temperature       | F     |

**Units/Mode Menu Page**

The Units/Mode page allows the user to define whether the meter is configured to display velocity or flow rate, as well as define the engineering units seen on the MAIN display and programming menus.

**Mode** – Select between Flow or Velocity for the MAIN display reading.

Options: Flow, Velocity

**Linear** - Select unit for the pipe dimensions and sensor spacing measurement.

Options: in (inches), ft (feet), m (meters) or mm (millimeters)

**Volume** – Select units for volume domain.

Options: USG (US gallons), ft<sup>3</sup> (cubic feet), L (liters), m<sup>3</sup> (cubic meters)

**Velocity** – Select units for flow velocity and fluid sonic velocity.

Options: ft/s (feet per second), m/s (meters per second)

**Flow** – Select units for volumetric flow rate.

Options: USG/m (gallons per minute), m<sup>3</sup>/h (cubic meters per hour), L/s (Liters per second), ft<sup>3</sup>/m (cubic feet per minute), L/m (Liters per minute)

**Temperature** – Select units for temperature domain.

Options: F (Degrees Fahrenheit), C (Degrees Celsius)

## 4.5 PROGRAMMING MENU PAGES (Continued)

```

--Setup-----
▶ Sensor      SE16B
  Angle       37
  Fluid       Water
  Temp Mode   Fixed
  Temp        77.0 F
  Pipe        PVC
  OD          4.5000 in
  Wall        0.2500 in
  Lining      None
  Crossings   2
  Zero Tare   No
  Sens Space  2.299 in
  Velocity    0.00 ft/s

Signal Strength 100%

```

**Setup Menu Page**

The Setup page allows the user to define the type of transducer used and to define process conditions like pipe material, size, fluid type and temperature. After these settings are defined, the spacing distance will be displayed on this page, and once the transducers are installed the meter will be ready to work.

All of these settings are pre-configured by ONICON before shipment. These settings should only be adjusted if the process conditions provided to ONICON at time of order were incorrect, or different transducers were supplied for field installation.

**Sensor** – Choose SE16A for 10 Series transducers, SE16B for 20 Series transducers, or SE16C for 30 Series transducers.

**Angle** – Only available when SE16B selected above- Select the angle of the transducer. Contact ONICON for assistance defining what angle sensors you have.

**Fluid** – Select between Water or Other. When Water is selected, the speed of sound of the fluid is determined based on the temperature entered later in this Setup menu.

**Vel@25C** – Only appears if “Other” was selected at the Fluid option. Enter the speed of sound of the fluid at 77°F (25°C). Units are defined by what was selected in the Units/Mode menu.

**dV/C** – Only appears if “Other” was selected at the Fluid option. This defines how much the speed of sound varies per degree C. This should be left at 0 unless the speed of sound change of the fluid is linear with respect to temperature.

**Temp Mode** – Defaulted at “Fixed”

**Temp** – Temperature of the fluid. If “Water” was selected at Fluid, enter the water temperature. If “Other” was selected at Fluid, enter 25.0°C or 77.0°F for the fluid temperature, depending on units of measurement selected.

**Pipe** – Select the pipe material.

Options: Carbon Steel, Brass, Aluminum, Acrylic, ABS, Other, Stainless 430, Stainless 410, Stainless 347, Stainless 316, Stainless 304, Stainless 303, Stainless 302, Mild Steel, PVC, Poly HD, Poly LD, Nylon, Iron, FRP, Ductile Iron, CPVC, Copper, Cast Iron.

**Vel** – If “Other” pipe material was chosen, enter the sonic velocity of the pipe material here. Units of measurement are defined in the Setup menu.

**OD** – Enter the pipe’s outside diameter in units defined in the Setup menu. Charts with standard pipe sizes based on schedule are provided in the appendix of this manual.

**Wall** – Enter the pipe’s wall thickness in units defined in the Setup menu. Charts with standard pipe sizes based on schedule are provided in the appendix of this manual.

**Lining** – Select whether or not the pipe the meter is being mounted to has a liner.

Options: None, Tar Epoxy, Rubber, Mortar, Asb Cement, Other

**Thick** - Enter the liner thickness in units defined in the Setup menu. Only appears if Lining is not “None”.

4.5 PROGRAMMING MENU PAGES (Continued)

```

--Setup-----
▶ Sensor      SE16B
  Angle      37
  Fluid      Water
  Temp Mode   Fixed
  Temp       77.0 F
  Pipe       PVC
  OD         4.5000 in
  Wall       0.2500 in
  Lining     None
  Crossings  2
  Zero Tare  No
  Sens Space  2.299 in
  Velocity   0.00 ft/s

Signal Strength 100 %
    
```

**Crossings** – Defines the number of times the ultrasonic signal crosses the inside of the pipe. The first choice used should be 2 or 4 crosses.

1 crossing is a "Z" or "Direct" mode, 2 crossings is a "V" or "Reflect" mode, and 4 crossings is a "W" or "Double Reflect" mode. 1 crossing will provide the largest signal strength but more diligence is required to mount the transducers properly.

2 crossings provide the easiest means to mount the transducers, averages some of the flow distortions in the pipe, but attenuates the signal more than 1 cross. This is the default and ONICON recommended configuration.

4 crossings provide even more averaging than 2 crosses. 4 crosses will not be an option unless the transducers overlap in a 2 cross setup, which is dependent on pipe settings (Refer to the drawings on pages 11 and 12) and fluid sonic velocity.

**Zero Tare** – Used to suppress readings or fluctuations at zero flow. Do not enable this function unless flow in the pipe has been valved to 0, and the pipe is full.

**Sens Space** – This function is not editable. This value will automatically calculate after the sensor type, angle, fluid type and temperature, pipe material and size, and number of crossings is defined. This distance is defined as the measurement between the inside of both transducers.

Because the meter comes pre-programmed from ONICON, this number is already defined for you on the Site Installation Details sheet. However, if any of the factors listed above are changed in the field, you will need to change the transducer spacing to the new number provided here.

**Velocity** – After mounting the transducers and connecting the transducer cable, you will be able to see the flow velocity in real-time once flow is established.

**Signal Strength** – After mounting the transducers and connecting the transducer cable, you will be able to see the signal strength in real-time. The pipe must be full of water to get a valid signal strength reading.



4.5 PROGRAMMING MENU PAGES (Continued)

```

--Calibration-----
▶ Mode                Flow
  20mA   500.00 USG/m
  4mA    0.00 USG/m
LOS Time                10 sec
Min Flow   4.00 USG/m
Damping
  Mode                FIR
  Percent             10%
  Window             1.0 ft/s
Cal Constant          1.00
    
```

**Calibration Menu Page**

The calibration menu defines the behavior of the flow measurement and its related outputs.

**Mode** – Shows the Mode which was selected in the Units/Mode menu. Could be “Flow” or “Velocity.”

**20 mA at or 5V at** – Enter the desired flow rate to be equal to 20 mA or 5V.

**4 mA at or 0V at** – Enter the desired flow rate to be equal to 4 mA or 0V. Typically, 0 flow/velocity, but could be a negative value if you wanted the 4-20 mA/0-5V output to represent more than one direction.

**LOS Time** - Value which suppress intermittent loss of signal.

Example: Systems with high concentrations of undissolved gasses will cause fluctuations in signal strength when the gasses move past the ultrasonic signal. If a complete loss of signal is experienced, the F-4300 will hold the last valid reading for the duration of the LOS Time.

If the signal strength returns before the LOS Time is expired, because the ultrasonic signal is no longer being impeded, the meter will return to normal operation automatically.

If signal strength does not return after the LOS Time has expired, the meter will report zero flow on the LCD display and outputs, and produce a Low Signal alarm.

Default LOS Time is 30 seconds, and the value can be set between 0 and 99 seconds.

**Min Flow** – Value which if the measured flow rate falls below, the meter will force the reading and outputs to 0. Units match those configured in the Units/Mode menu. The default and recommended value is the volumetric flow rate equivalent to 0.1 ft/sec in your pipe size.

**Damping** – The damping value stabilizes the flow rate on the display and analog output. For applications with poor straight run, use a higher dampening value to steady the flow reading. Lower dampening values should be used in applications where you want a faster response from the meter. The default dampening value is 20%.

**Cal Constant** – Calibration constant defined during calibration. This value shouldn't be changed unless ONICON support has requested to do so.

4.5 PROGRAMMING MENU PAGES (Continued)

```

--Relay Parameters--
▶ Relay          1
  Function       Flow
  On             1000 USG
  Off            0.000 USG
    
```

**Relay Parameters Menu Page**

The relay parameters page is where changes can be made to the pulse outputs available with the F-4300.

**Relay** – Defines which pulse output you are making changes to, either 1 or 2.

**Function** – Defines the behavior of the pulse output selected at the Relay option. Choices:

**On** – Pulse is always engaged

**Off** – Pulse is always disengaged

**Pulse** – Scaled pulse. Define how many gallons must be measured before a pulse occurs. Pulse duration = 50 ms; max Hz = 10

**Flow** – Pulse output functions as a flow alarm. You will need to define when the alarm comes ON, and when the alarm will turn OFF again.

Examples:

High Flow Alarm: ON = 300 GPM, OFF = 250 GPM

Flow goes above 300 GPM and the pulse output latches ON. It will not turn OFF until flow goes below 250 GPM.

**Direction**- Direction Switch ON = +0.1 GPM, OFF = -0.1 GPM

Any flow above 0.1 GPM will cause the pulse to turn ON, and it will turn off should flow reverse.

```

--Data Logging-----
▶ Log Site ID    01
  Mode           Flow
  File Format    .LG2
  Date          Mar. 20/2020
  Time          12:28:41
  Interval      30sec
  Data Log      Logging
    
```

**Data Logging Menu Page**

The Data Logging page allows configuration of the data logger. Options include what is being logged, how often it is being logged, and the date settings.

The F-4300's internal log memory can be saved up to 128MB, 26 million data points.

**IMPORTANT NOTE**

*The logger must be configured in a specific order in order to function correctly:*

1. Set the Log Site ID, Mode, File Format, Date, Time, and Interval to the desired option.
2. Under Data Log, select "Delete"
3. Under Data Log, select "Start"
4. Deploying the logger in any other order will compromise the settings you've chosen.

4.5 PROGRAMMING MENU PAGES (Continued)

```

--Data Logging-----
▶ Log Site ID      01
  Mode             Flow
  File Format      .LG2
  Date            Mar. 20/2020
  Time            12:28:41
  Interval        30sec
  Data Log        Logging
    
```

**Log Site ID** – Provide a number to the log site you’re creating. Can be any number between 00-99.

**Mode** – Define what is being logged. Options: Flow, Velocity.

Once option selected, press  to store the setting. This setting cannot be changed after a log was started. To change, first stop the log, then change the mode.

**File Format** – Define how you will want the data presented when downloaded. Choose .LG2 when you will be looking at the log data with the ONICON Logger Utility software. Choose .CSV when you will be loading the data directly into an Excel spreadsheet for manipulation and graphing.

**Date** – Configure today’s date. Format: Month Day/Year.

**Time** – Configure the time. Format: hh:mm:ss. Range: 00:00:00-23:59:59.

**Interval** – Define how often the unit selected under Mode will log.

Options: 10 sec, 30 sec, 1 min, 2 min, 5 min, 10 min, 15 min, 30 min, and 60 min.

At the fastest interval, 10 sec, the logger will last 8.5 years before it is full. However, if you are curious about the % log used, it is available in the Messages Menu accessible from the Run Screen by pressing the .

Although the logger storage capability is quite extensive, ONICON recommends not using an interval more resolute than required, as downloading a large log file could present data transfer problems and corrupted data.

**Data Log** – Stop, Start or Delete the log file.

**IMPORTANT NOTE:**

**You MUST Delete an old log and Start a new log AFTER having made changes to Log Site ID, Mode, Date, Time and/or Interval for those changes to be applied.**

**IMPORTANT NOTE**

**Changing any of the parameters in the Units/Mode menu will start a new log. It is recommended that you Delete and start a new log after changing any Units/Mode settings.**

4.5 PROGRAMMING MENU PAGES (Continued)

```

--Data Logging-----
▶ Log Site ID      01
  Mode             Flow
  File Format      .LG2
  Date            Mar. 20/2020
  Time            12:28:41
  Interval        30sec
  Data Log        Logging
    
```

**Retrieving Log File**

Plug a USB Flash Memory Drive into the USB Type-A output port on the panel of the meter. The instrument display will show the data download icon until the log file is transferred to the memory card. The USB flash drive may be removed when the icon for download successful appears.

Download file names will appear in this format:

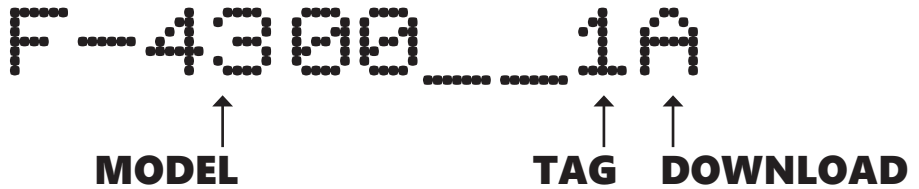

Tag is set according to the Log Site ID entered in the instrument Data Logging menu.

Download letter will be A for the first download from an instrument. B for the second, then C etc. At the letter Z a - character will appear indicating that the maximum number of downloads for that instrument are on the USB flash drive. Older files can be erased or moved from the flash memory drive or a new memory drive can be used.

**IMPORTANT NOTE**

**Downloading files in .LG2 format will take approximately 35 seconds per 1% of internal log memory used.**

**Downloading files in .CSV format will take approximately 8 minutes per 1% of internal log memory used.**

**Opening .LG2 Files**

Install ONICON F-4300 Logger Utility on your PC or laptop. Select File/Open/Instrument Log (.log) to open the log file from your USB flash drive. ONICON F-4300 Logger Utility is available on ONICON’s website, <https://www.onicon.com/products/f-4300-series-clamp-on-ultrasonic-flow-meter/>. Data can also be converted to .CSV via ONICON F-4300 Logger Utility.

**Opening .CSV Files**

Use a datasheet program such as Microsoft Excel® to import data in a comma delimited format. Use Excel to manipulate or graph data.

4.5 PROGRAMMING MENU PAGES (Continued)

```

--Communication--
Protocol      Modbus
Address       001
BPS           9600
Parity        Even
Stop Bits     1
    
```

**Communications Menu Page**

The communications menu provides the means to select the serial output of the meter, and the addressing and communication speed.

**Protocol** – Select the protocol for the serial communications.

Options: OFF, MODBUS, BACnet

**DevID** – Only available if BACnet was the selected Protocol. This is the Device ID which must be unique for the device across the whole BACnet network.

Range: 0-4,194,302.

**MAC Address** – Only available if BACnet was the selected Protocol. This is the RS485 bus address for the BACnet MS/TP communications.

Range: 0-127 for master devices, 128-254 for slave devices.

**BPS** – Baud Rate, or Bits Per Second. Defines the speed of communication on the BUS. Must be the same for all devices on the BUS.

Options: 9600, 19200, 38400, 76800.

```

--Special Functions--
▶ Language      English
Analog Out     4-20mA
Backlight      High
Reset Totalizer NO
Neg. Totals    NO
Rev. Flow      OFF
Capture Par    NO
Capture WF     NO
Restore Defaults NO
New Password   0000
    
```

**Special Functions Menu Page**

**Language** – Select the language for the menus and displays.

Options: English, French, Spanish.

**Analog Out** – Defines the analog output type. Options: 4-20 mA, 0-5V.

**Backlight** – Raise or lower the brightness of the display backlight.

Options: Off, High, Med, Low, Key Hi/Lo (Brightness goes to High after a keypress, then Low after 1 minute of no button presses), Key High, Key Med, and Key Low (Brightness goes to specified value after keypress, then OFF after 1 minute).

**Reset Totalizer** – Select YES to reset totalizer. YES will flash two times after pressing  to indicate the action was accepted.

**Neg. Totals** – Selecting NO will cause the totalizer to ignore flow rates in the negative direction. Only positive flows will accumulate the totalizer. Selecting YES will cause negative flows to deduct from the totalizer. Totalizer values can achieve a negative value if negative totals are greater than positive totals.

**Rev.Flow** - Select ON/ OFF to enable/ disable flow direction measurement.

Select INVERT to invert the sense of the flow measurement.

**Capture Par** - This function captures the programming parameters in the meter. Select YES, then wait for INSRT USB to appear, then insert a USB drive into the USB port to transfer the parameters. After Saving flashes, DONE will appear on the screen, meaning it is safe to remove the USB.

**Capture WF** - This function captures the ultrasonic signal so that it can be evaluated by ONICON. Contact ONICON for the instructions.

**Restore Defaults** – Selecting YES will cause all of the programming settings to revert to the factory default. These defaults are different than the programming ONICON performed at the factory before the meter was shipped.

**New Password** – This function allows a new password to be set. This password protects the programming menu access from the Main Display. The default value is 0000. Range: 0000-9999. Do not lose the password if changed, in case you need to return to the programming menu at a later date.

4.5 PROGRAMMING MENU PAGES (Continued)

```

--Simulation-----
▶ Test           Actual
Flow            250USG/m
4-20mA Flow    5.60mA
Relays          1 2 3 4 5 6
    
```

**Simulation Menu Page**

The simulation menu page is used to generate flow rates independent of the actual measurement in the system, in order to test output signals.

Any simulated flow rate is only active while the Simulation Menu is open. Once the menu is exited, the flow rate and output signal behavior will return to that actually measured by the meter.

**Test** – This function defines how the simulation mode will be tested. Options: Actual, Maximum, Minimum.

When Actual is selected, any flow rate which is currently present will be displayed on the screen, and the outputs associated with that flow rate is also displayed. Alternatively, you can move the cursor to the Flow option, press **➡** to enter the option, and then set a flow rate manually. After **✓** is pressed, the analog output and pulse outputs will be driven by the set flow rate.

When Maximum is selected, the flow rate will be driven to the 20 mA/5V value configured in the Calibration Menu Page.

When Minimum is selected, the flow rate will be driven to the 4 mA/0V value configured in the Calibration Menu Page.

```

--Configuration-----
Serial#         12345
Utility         1.26.0.5
Transit Time    1.38.1
CommBoard      1.18.0
Relays          2
Analog Out     1
    
```

**Configuration Menu Page**

The configuration menu page stores the serial number and electronics information for the F-4300. All of the values in this menu are read-only.

**Serial #** - Serial number of the F-4300. This value is also present on the outside of the enclosure, and inside the door.

**Utility** – Revision of the utility card. The utility card is the vertical card on the left hand side of the chassis. It connects to the LCD display, and has the analog and pulse outputs on it.

**Transit Time** – Revision of the transit time card. The Transit time card is the topmost horizontal card, with the two connectors attached to the Triax cable.

**CommBoard** —Revision of the communications card.

**Relays** – Lists the number of pulse outputs present on the meter. This should always be 2.

**Analog Out** – Lists the number of analog outputs present on the meter. This should always be 1.

## SECTION 5.0 BACNET MS/TP

BACnet MS/TP, serial interface connections are connected at the RS485 card's terminal block.

Transceiver: 2-wire, half-duplex  
 BACnet® address (MAC address) range: 1 - 247 (Default: 017)  
 Device Instance: Baud rate: 0 - 4,194,302 (Default: 57017)  
 9600, 19200, 38400 or 76800  
 (Default: 38400)  
 Termination: 120 ohms or none  
 (Default: none)  
 Jumper JP1 position 1 + 2 = OFF  
 Jumper JP1 position 2 + 3 = ON  
 Biasing: None  
 Flow control: None

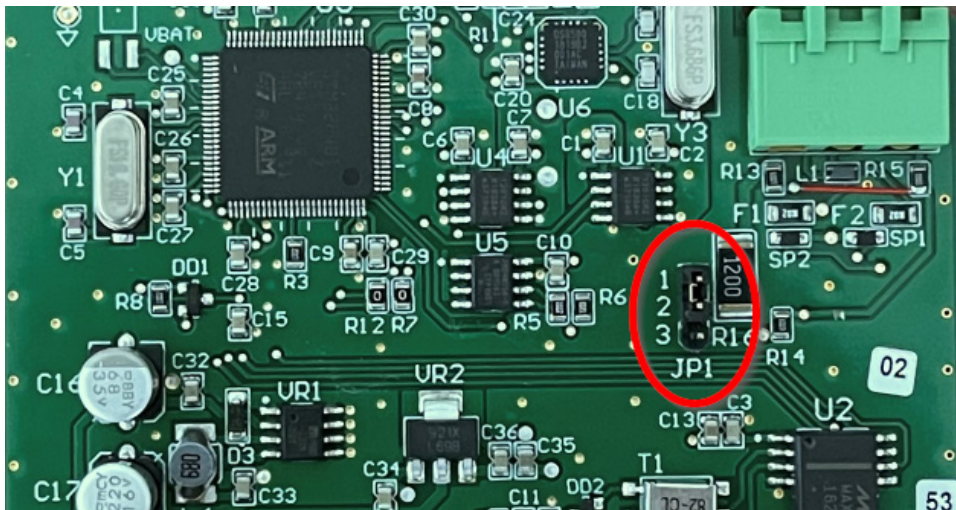

RS485 Output Card with Jumper JP1

**5.1 BACNET PROTOCOL IMPLEMENTATION CONFORMANCE STATEMENT**

|                                      |           |
|--------------------------------------|-----------|
| <b>Application Software Version:</b> | 1.26.2.14 |
| <b>Firmware Revision:</b>            | 001.023.0 |
| <b>BACnet Protocol Revision:</b>     | 10        |

**BACnet Standardized Device Profile (Annex L):**

BACnet Application Specific Controller (B-ASC)

**BACnet Interoperability Building Blocks Supported (Annex K):**

|                 |                 |                 |                 |                 |
|-----------------|-----------------|-----------------|-----------------|-----------------|
| <b>DS-RP-B</b>  | <b>DS-WP-B</b>  | <b>DM-DDB-B</b> | <b>DM-DCC-B</b> | <b>DM-UTC-B</b> |
| <b>DS-RPM-B</b> | <b>DS-WPM-B</b> | <b>DM-DOB-B</b> | <b>DM-TS-B</b>  |                 |

**Segmentation Capability:** Not supported

**Standard Object Types Supported:** (See Tables 1 – 8 on the following pages for optional & writable properties)

All objects:

- CreateObject Service: Not supported
- DeleteObject Service: Not supported

**Data Link Layer Options:**

MS/TP master (Clause 9), baud rate(s): 9600, 19200, 38400 & 76800

**Device Address Binding:**

Is static device binding supported  Yes  No

**Networking Options:** Not supported

**Character Sets Supported:**

ISO 10646 (UTF-8)

**Gateway Options:** Not supported

**Network Security Options:**

Non-secure Device – is capable of operating without BACnet Network Security



5.1 BACNET PROTOCOL IMPLEMENTATION CONFORMANCE STATEMENT (CONTINUED)

Table 1.

| <b>Device Object</b>                 |  |                 |                   |
|--------------------------------------|--|-----------------|-------------------|
| <b>Property</b>                      | <b>Default Value</b>   | <b>Writable</b> | <b>Comment</b>    |
| Object Identifier                    | 57017  | Yes             | 0 – 4,194,303     |
| Object Name                          | F-4300-XXXXXX  | Yes             | X = serial number |
| Object Type                          | Device   | No              |                   |
| System Status                        | Operational  | No              |                   |
| Vendor Name                          | ONICON Inc.  | No              |                   |
| Vendor Identifier                    | 206  | No              |                   |
| Model Name                           | F-4300   | No              |                   |
| Firmware Revision                    | 001.023.000  | No              |                   |
| Application Software Version         | 001.023.000  | No              |                   |
| Object List                          | (device, 1), (analog input, 1 – 4), (analog value, 1 – 4), (binary value, 1 – 3), (multi-state value, 1) | No              |                   |
| Max ADPU Length                      | 480  | No              |                   |
| Segmentation Supported               | No Segmentation  | No              |                   |
| APDU Timeout                         | 6000   | Yes             |                   |
| # of ADPU Retries                    | 3  | Yes             |                   |
| Device Address Binding               | {}   | No              |                   |
| Database Revision                    | 1  | No              |                   |
| Property list                        |  | No              |                   |
| <b>Optional Properties Supported</b> |  |                 |                   |
| Description                          | Customer Description   | Yes             | 32 char. Max.     |
| Local Time                           | Device current time  | Yes             |                   |
| Location                             | Customer location  | Yes             | 32 char. Max.     |
| Local Date                           | Device current date  | Yes             |                   |
| UTC Offset                           | -300   | Yes             |                   |
| Daylight Savings Status              | False  | Yes             |                   |
| Max Master                           | 127  | Yes             |                   |
| Max Info Frames                      | 1  | No              |                   |

5.1 BACNET PROTOCOL IMPLEMENTATION CONFORMANCE STATEMENT (CONTINUED)

Table 2.

| <b>Analog Input</b>                  |                      |                 |                |
|--------------------------------------|----------------------|-----------------|----------------|
| <b>Property</b>                      | <b>Default Value</b> | <b>Writable</b> | <b>Comment</b> |
| Object Identifier                    | Analog Input 1 – 10  | No              |                |
| Object Name                          | Various              | Yes             |                |
| Object Type                          | Analog input         | No              |                |
| Present Value                        | Real                 | No              | See note 1.    |
| Status Flags                         | F, F, F, F           | No              |                |
| Event State                          | Normal               | No              |                |
| Reliability                          | No-fault detected    | No              |                |
| Out of Service                       | FALSE                | No              |                |
| Units                                | Various              | No              |                |
| Property List                        |                      | No              |                |
| <b>Optional Properties Supported</b> |                      |                 |                |
| Description                          | Analog-input #, Name | Yes             |                |

Note 1. This property is commandable when the OUT\_OF\_SERVICE is true.

Table 2a.

| <b>Object Identifier</b> | <b>Object Name</b> | <b>Description</b>                |
|--------------------------|--------------------|-----------------------------------|
| Ai 1                     | Velocity Reading   | Velocity at the meter             |
| Ai 2                     | Flow Rate          | Volume flow rate at the meter     |
| Ai 3                     | Sonic Velocity     | Speed of sound through the liquid |
| Ai 4                     | Signal Strength    | Flow transducer signal strength   |

Table 3.

| <b>Analog Value</b>                  |  |                 |                |
|--------------------------------------|--|-----------------|----------------|
| <b>Property</b>                      | <b>Default Value</b>   | <b>Writable</b> | <b>Comment</b> |
| Object Identifier                    | Analog Value 1 through 24  | No              |                |
| Object Name                          | Various  | Yes             |                |
| Present Value                        | Real   | No              |                |
| Status Flags                         | F, F, F, F   | No              |                |
| Event State                          | Normal   | No              |                |
| Out of Service                       | FALSE  | No              |                |
| Units                                | Various  | No              |                |
| Property List                        |  | No              |                |
| <b>Optional Properties Supported</b> |  |                 |                |
| Description                          | Analog-value #, Name   | Yes             |                |
| Priority Array                       | {NULL, NULL, NULL, NULL, NULL, NULL, NULL, NULL, NULL, NULL, NULL, NULL, NULL, NULL, NULL, NULL} | No              |                |
| Relinquish Default                   |  | No              |                |

5.1 BACNET PROTOCOL IMPLEMENTATION CONFORMANCE STATEMENT (CONTINUED)

Table 3a.

| Object Identifier | Object Name            | Description                        |
|-------------------|------------------------|------------------------------------|
| AV 1              | Volume Total           | Total flow volume                  |
| AV 2              | Logging Used           | Log memory used                    |
| AV 3              | Previous Day Avg. Flow | Average flow rate for previous day |
| AV 4              | Previous Day Volume    | Volume total for previous day      |

Table 4.

| Binary Value                  |  |          |         |
|-------------------------------|--|----------|---------|
| Property                      | Default Value  | Writable | Comment |
| Object Identifier             | Binary Value 1 – 9   | No       |         |
| Object Name                   | Various  | Yes      |         |
| Present Value                 | 0  | Yes      |         |
| Status Flags                  | F, F, F, F   | No       |         |
| Event State                   | Normal   | No       |         |
| Out of Service                | FALSE  | No       |         |
| Property List                 |  | No       |         |
| Optional Properties Supported |  |          |         |
| Description                   | Binary-Value #, Name   | Yes      |         |
| Inactive Text                 | Various  | No       |         |
| Active Text                   | Various  | No       |         |
| Priority Array                | {NULL, NULL, NULL, NULL, NULL, NULL, NULL, NULL, NULL, NULL, NULL, NULL, NULL, NULL, NULL} | Yes      |         |
| Relinquish Default            |  | Yes      |         |

Table 4a.

| Object Identifier | Object Name        | Description                        |
|-------------------|--------------------|------------------------------------|
| BV 1              | Reset Volume Total | Reset volume total                 |
| BV 2              | Relay 1 State      | Indicates current state of relay 1 |
| BV 3              | Relay 2 State      | Indicates current state of relay 2 |

5.1 BACNET PROTOCOL IMPLEMENTATION CONFORMANCE STATEMENT (CONTINUED)

Table 5.

| <b>Multi-state Value</b>             |                      |                 |                |
|--------------------------------------|----------------------|-----------------|----------------|
| <b>Property</b>                      | <b>Default Value</b> | <b>Writable</b> | <b>Comment</b> |
| Object Identifier                    | Multi-state Value 1  | No              |                |
| Object Name                          | Various              | Yes             |                |
| Present Value                        | 0                    | No              |                |
| Status Flags                         | F, F, F, F           | No              |                |
| Event State                          | Normal               | No              |                |
| Out of Service                       | FALSE                | No              |                |
| Number of States                     | Varies               | No              |                |
| Property List                        |                      | No              |                |
| <b>Optional Properties Supported</b> |                      |                 |                |
| None                                 |                      |                 |                |

Table 5a.

| <b>Object Identifier</b> | <b>Object Name</b> | <b>Description</b>  |
|--------------------------|--------------------|---|
| MSV 1                    | Flow Sensor Status | Indicates flow sensor status<br>0 – sensor good<br>1 – low signal<br>2 – sensor open<br>3 – sensor short<br>4 – sensor check calibration<br>5 – sensor relay fault<br>6 – sensor system fault |

## SECTION 6.0: MODBUS

MODBUS serial interface connections are connected at the RS485 or TCP/IP card's terminal block.

### 6.1 MODBUS RTU RS485

Transceiver: 2-wire, half-duplex

Data format: 8 Data Bits, 1 or 2 Stop Bits (Default: 1 Stop Bits)

Parity: None, Odd, or Even (Default: Even)

MODBUS MAC address (device address) range: 1 - 255 (Default: 017)

Baud rate: 9600, 19200, 38400, or 76800 (Default: 38400)

Termination: 120 ohms or none (Default: none)

Jumper JP1 position 1 + 2 = OFF

Jumper JP1 position 2 + 3 = ON

Biasing: None

Flow control: None

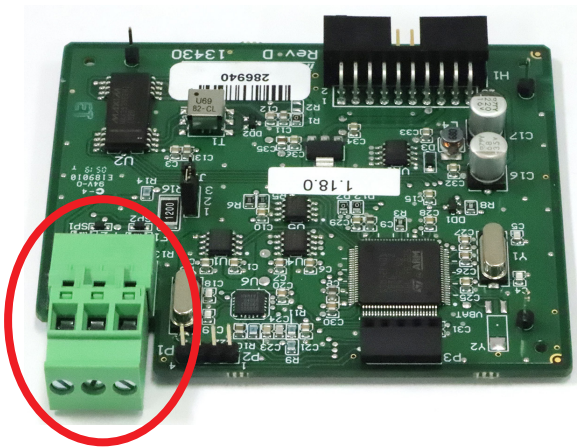

RS485 Output Terminal Block

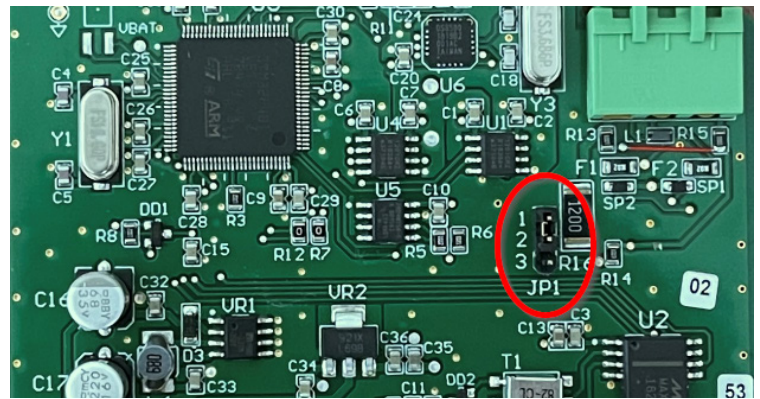

RS485 Output Card with Jumper JP1

### 6.2 MODBUS TCP/IP

Transceiver: 10/100 Base-TX and RJ45 connector

Port: 502

Parity: None

MODBUS MAC Address range: 1-255 (Default: 017)

Baud rate: 38400

IP Address: 192.168.255.1

Mask: 255.255.0.0

Gateway: 192.168.0.1

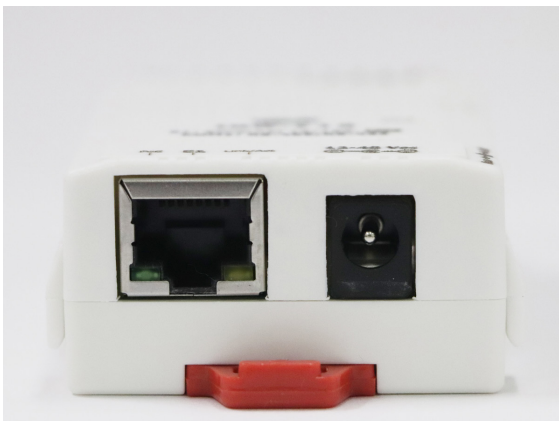

### 6.2.1 IP Address Setting (IPv4)

Changing the IP address of the F-4300 requires the use of a PC with an Ethernet card and an available port. The default IP configuration of the F-4300 is as follows:

IP Address 192.168.255.1  
 Mask 255.255.0.0  
 Gateway 192.168.0.1

The interface shown above is used to configure the IP settings on the F-4300. The Login Password is admin (case sensitive). Press Submit after entering the password, and the following page appears:

To change these IP address settings:

- Connect the Ethernet cable to the RJ45 jack on the TCP/IP card
- Change the adapter settings in your PC as shown:

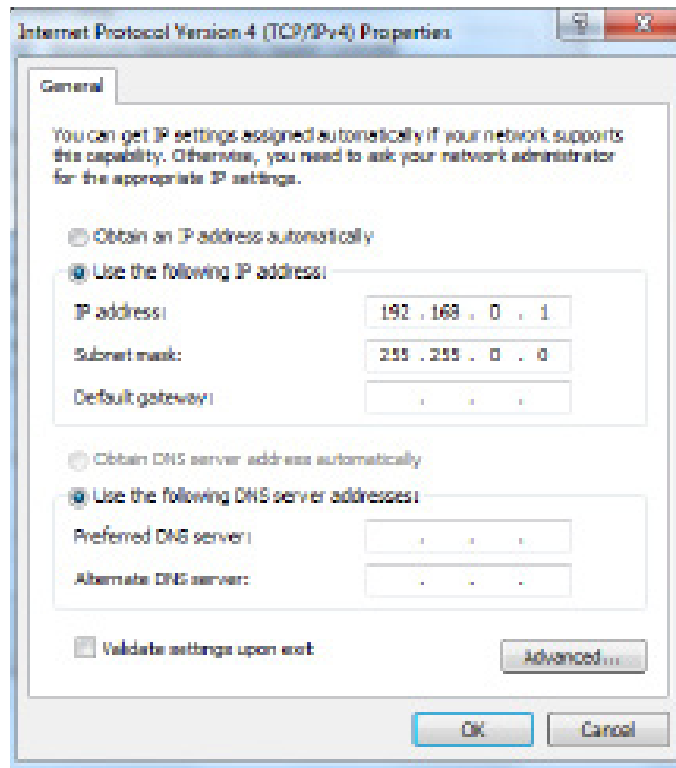

Next, open a web browser, and navigate to IP address 192.168.255.1. The following page will appear:

**The system is logged out.**  
 To enter the web configuration, please type password in the following field.

Login password

*Note: This web configuration requires JavaScript enabled in your browser (Firefox, IE...).*  
*If the web configuration does not work, please check the JavaScript settings first.*

*When using IE, please disable its cache as follows.*  
*Menu items: Tools / Internet Options... / General / Temporary Internet Files / Settings... / Every visit to the page*

### 6.2.1 IP Address Setting (IPv4) (Continued)

The interface shown above is used to configure the IP settings on the F-4300. The Login Password is admin (case sensitive). Press Submit after entering the password, and the following page appears:

| Status & Configuration |                       |   |                   |
|------------------------|-----------------------|---|-------------------|
| Model Name             | IGW-715               | Alias Name                                  | Tiny_R_And_D      |
| Firmware Version       | v1.4.6 [Aug 05, 2014] | MAC Address                                 | 00-0d-e0-80-41-33 |
| IP Address             | 192.168.255.1         | TCP Port Timeout (Socket Watchdog, Seconds) | 180               |
| Initial Switch         | OFF                   | System Timeout (Network Watchdog, Seconds)  | 300               |

**Current port settings:**

| Port Settings        | Port 1 |
|----------------------|--------|
| Baud Rate (bps)      | 38400  |
| Data Size (bits)     | 8      |
| Parity               | None   |
| Stop Bits (bits)     | 1      |
| Modbus Protocol      | RTU    |
| Slave Timeout (ms)   | 300    |
| Char Timeout (bytes) | 4      |
| Silent Time (ms)     | 0      |
| Read Cache (ms)      | 800    |

Seven pages are available from the main menu:

**Home** – The page you currently see. This page is not used to configure the IP address.

**Port1** – Not used.

**Network** – This page allows you to change the IP address settings.

**Filter** – Not used.

**Monitor** – Not used.

**Password** – This page can be used to change the password from the default admin.

**Logout** – Press this button to logout of the F-4300 IP configurator.

Press the Network button to arrive at the following page:

Within the IP Address Selection section, you can configure the IP settings for the F-4300’s MODBUS communications.

| Network and Miscellaneous Settings |                       |   |                   |
|------------------------------------|-----------------------|---|-------------------|
| Model Name                         | IGW-715               | Alias Name                                  | Tiny_R_And_D      |
| Firmware Version                   | v1.4.6 [Aug 05, 2014] | MAC Address                                 | 00-0d-e0-80-41-33 |
| IP Address                         | 192.168.255.1         | TCP Port Timeout (Socket Watchdog, Seconds) | 180               |
| Initial Switch                     | OFF                   | System Timeout (Network Watchdog, Seconds)  | 300               |

**IP Address Selection**

| Address Type   | Status    | IP   | Subnet | Gateway | MAC Address | Gateway Net ID |
|--|-----------|--|--------|---------|-------------|----------------|
| Static IP Address  | Static IP | 192  | 168    | 255     | 1           |                |
| Subnet Mask  |           | 255  | 255    | 0       | 0           |                |
| Default Gateway  |           | 192  | 168    | 0       | 1           |                |
| MAC Address  |           | 00-0d-e0-80-41-33 (Format FF-FF-FF-FF-FF-FF) |        |         |             |                |
| Gateway Net ID   |           | 255 (Default: 255)                           |        |         |             |                |
| Note: This is reserved for gateway, NOT for slave devices. |           |  |        |         |             |                |
| Update Settings  |           |  |        |         |             |                |

**Address Type** – Choose between Static IP, and DHCP. The Static IP Address, Subnet Mask, and Default Gateway will become un-editable if DHCP is selected.

After the configuration has been updated, press the **Update Settings** button to save the changes. Document the configuration chosen. After pressing the update button, if you need to access these settings again, you must go back into your PC’s IP setting page and change the IP address and subnet to match the network the F-4300 is set for.

After you are done making configuration changes, you are ready to connect the F-4300 to the MODBUS TCP/IP network.

### 6.2.2 IP Address Setting (IPv6)

The default meter IPv6 address is shown in the field highlighted in yellow below. This section is part of the web browser interface Network tab. Use the field outlined in red below to enter a new IPv6 address for the meter. Press **Update Settings** button to save the change.

#### IP Address Selection

|  |  |     |     |   |
|--|--|-----|-----|---|
| Address Type                                   | Static IP ▾                                    |     |     |   |
| Static IPv4 Address                            | 192  | 168 | 255 | 1 |
| Subnet Mask                                    | 255  | 255 | 0   | 0 |
| Default Gateway                                | 192  | 168 | 0   | 1 |
| MAC Address                                    | 00-0d-e0-81-42-eb (Format: FF-FF-FF-FF-FF-FF)  |     |     |   |
| IPv6 Link Local Address                        | fe80:0:0:20d:e0ff:fe81:42eb                    |     |     |   |
| IPv6 SLAAC Address                             | 0:0:0:0:0:0:0:0                                |     |     |   |
| SLAAC Timeout (SLAAC Watchdog)                 | 0 (30 ~ 65535 seconds, Default: 0, Disable: 0) |     |     |   |
| IPv6 User-defined Address                      | fc00:0:0:0:0:0:0:1                             |     |     |   |
| <input type="button" value="Update Settings"/> |  |     |     |   |

### 6.3 UNITS AND FUNCTIONS

| Engineering Units                                     | Abbreviation         | Engineering Units   | Abbreviation    |
|---|----------------------|---------------------|-----------------|
| <b>Volume Rate (Flow)</b>                             |                      | <b>Volume Total</b> |                 |
| Gallons per minute                                    | GPM                  | Gallons             | Gal             |
| Cubic meters per hour                                 | m <sup>3</sup> /hr   | Liters              | Liters          |
| Cubic feet per minute                                 | ft <sup>3</sup> /min | Cubic Feet          | ft <sup>3</sup> |
| Liters per second                                     | L/s                  | Cubic Meters        | m <sup>3</sup>  |
| Liters per minute                                     | L/m                  |                     |                 |
| <b>Velocity (Flow velocity, Fluid speed of sound)</b> |                      |                     |                 |
| Feet per second                                       | ft/s                 |                     |                 |
| Meters per second                                     | m/s                  |                     |                 |

| Function Codes Supported:     |
|-------------------------------|
| 01 - Read Coil(s)             |
| 02 - Read Discreet Input(s)   |
| 04 - Read Input Register(s)   |
| 05 - Write Single Coil        |
| 06 - Write Single Register    |
| 15 - Write Multiple Coils     |
| 16 - Write Multiple Registers |
| 17 - Report Slave ID          |



6.4 MODBUS MEMORY MAP

| Register Address | Description                   | Register Type | Data Range | Over Range | Read/Write | Comments   |
|------------------|-------------------------------|---------------|------------|------------|------------|--|
| 1                | Reset Volume Total            | Coil          | NA         | NA         | Read/Write | Turn coil ON (1) to reset total. Turn coil to OFF (0)once reset is complete.   |
| 2                | Reset User Energy Mode 1      | Coil          | NA         | NA         | Read/Write | Turn coil ON (1) to reset total. Turn coil to OFF (0)once reset is complete.   |
| 3                | Reset User Energy Mode 2      | Coil          | NA         | NA         | Read/Write | Turn coil ON (1) to reset total. Turn coil to OFF (0)once reset is complete.   |
| 4                | Reset User Volume Single Mode | Coil          | NA         | NA         | Read/Write | Turn coil ON (1) to reset total. Turn coil to OFF (0)once reset is complete.   |
| 5                | Reset User Volume Mode 1      | Coil          | NA         | NA         | Read/Write | Turn coil ON (1) to reset total. Turn coil to OFF (0)once reset is complete.   |
| 6                | Reset User Volume Mode 2      | Coil          | NA         | NA         | Read/Write | Turn coil ON (1) to reset total. Turn coil to OFF (0)once reset is complete.   |
| 7                | Reset Aux Input Count 1       | Coil          | NA         | NA         | Read/Write | Turn coil ON (1) to reset total. Turn coil to OFF (0)once reset is complete.   |
| 8                | Reset Aux Input Count 2       | Coil          | NA         | NA         | Read/Write | Turn coil ON (1) to reset total. Turn coil to OFF (0)once reset is complete.   |
| 9                | Reset Aux Input Count 3       | Coil          | NA         | NA         | Read/Write | Turn coil ON (1) to reset total. Turn coil to OFF (0)once reset is complete.   |
| 10               | Reset Aux Input Count All     | Coil          | NA         | NA         | Read/Write | Turn coil ON (1) to reset total. Turn coil to OFF (0)once reset is complete.   |
| 8                | Aux Output 1                  | Coil          | NA         | NA         | Read/Write | Turn coil ON (1) to latch Pulse/Relay # 1 closed. Turn coil to OFF (0) to latch Pulse/Relay # 1 open. Pulse/Relay # 1 must have been programmed for "MODBUS Coil" in the commissioning menu. |
| 9                | Aux Output 2                  | Coil          | NA         | NA         | Read/Write | Turn coil ON (1) to latch Pulse/Relay # 1 closed. Turn coil to OFF (0) to latch Pulse/Relay # 2 open. Pulse/Relay # 2 must have been programmed for "MODBUS Coil" in the commissioning menu. |
| 10               | Aux Output 3                  | Coil          | NA         | NA         | Read/Write | Turn coil ON (1) to latch Pulse/Relay # 1 closed. Turn coil to OFF (0) to latch Pulse/Relay # 3 open. Pulse/Relay # 3 must have been programmed for "MODBUS Coil" in the commissioning menu. |

6.4 MODBUS MEMORY MAP (CONTINUED)

| Register Address | Description                 | Register Type  | Data Range | Over Range | Read/Write | Comments  |
|------------------|-----------------------------|----------------|------------|------------|------------|---|
| 10001            | Pulse/Relay Output 1 Status | Discreet Input | 1-2        | NA         | Read Only  | 1-Indicates Pulse/Relay #1 is ON (Closed)<br>2-Indicates Pulse/Relay #2 is OFF (Open) |
| 10002            | Pulse/Relay Output 2 Status | Discreet Input | 1-2        | NA         | Read Only  | 1-Indicates Pulse/Relay #1 is ON (Closed)<br>2-Indicates Pulse/Relay #2 is OFF (Open) |
| 10003            | Pulse/Relay Output 3 Status | Discreet Input | 1-2        | NA         | Read Only  | 1-Indicates Pulse/Relay #1 is ON (Closed)<br>2-Indicates Pulse/Relay #2 is OFF (Open) |
| 10004            | Pulse/Relay Output 4 Status | Discreet Input | 1-2        | NA         | Read Only  | 1-Indicates Pulse/Relay #1 is ON (Closed)<br>2-Indicates Pulse/Relay #2 is OFF (Open) |
| 10005            | Pulse/Relay Output 5 Status | Discreet Input | 1-2        | NA         | Read Only  | 1-Indicates Pulse/Relay #1 is ON (Closed)<br>2-Indicates Pulse/Relay #2 is OFF (Open) |
| 10006            | Pulse/Relay Output 6 Status | Discreet Input | 1-2        | NA         | Read Only  | 1-Indicates Pulse/Relay #1 is ON (Closed)<br>2-Indicates Pulse/Relay #2 is OFF (Open) |

6.4 MODBUS MEMORY MAP (CONTINUED)

| Register Address | Description                      | Register Type  | Register Type                    | Comments |
|------------------|----------------------------------|----------------|----------------------------------|----------|
| 30001            | Flow Velocity - ft/s             | Input Register | Floating Point Register (1 of 2) |          |
| 30002            | Flow Velocity - ft/s             | Input Register | Floating Point Register (2 of 2) |          |
| 30003            | Flow Velocity - m/s              | Input Register | Floating Point Register (1 of 2) |          |
| 30004            | Flow Velocity - m/s              | Input Register | Floating Point Register (2 of 2) |          |
| 30101            | Flow Rate - GPM (USG/min)        | Input Register | Floating Point Register (1 of 2) |          |
| 30102            | Flow Rate - GPM (USG/min)        | Input Register | Floating Point Register (2 of 2) |          |
| 30103            | Flow Rate - L/sec                | Input Register | Floating Point Register (1 of 2) |          |
| 30104            | Flow Rate - L/ssec               | Input Register | Floating Point Register (2 of 2) |          |
| 30105            | Flow Rate - ft <sup>3</sup> /min | Input Register | Floating Point Register (1 of 2) |          |
| 30106            | Flow Rate - ft <sup>3</sup> /min | Input Register | Floating Point Register (2 of 2) |          |
| 30107            | Flow Rate - m <sup>3</sup> /hr   | Input Register | Floating Point Register (1 of 2) |          |
| 30108            | Flow Rate - m <sup>3</sup> /hr   | Input Register | Floating Point Register (2 of 2) |          |
| 30109            | Flow Rate - USG/sec              | Input Register | Floating Point Register (1 of 2) |          |
| 30110            | Flow Rate - USG/sec              | Input Register | Floating Point Register (2 of 2) |          |
| 30111            | Flow Rate - USG/hr               | Input Register | Floating Point Register (1 of 2) |          |
| 30112            | Flow Rate - USG/hr               | Input Register | Floating Point Register (2 of 2) |          |
| 30113            | Flow Rate - USG/day              | Input Register | Floating Point Register (1 of 2) |          |
| 30114            | Flow Rate - USG/day              | Input Register | Floating Point Register (2 of 2) |          |
| 30115            | Flow Rate - ft <sup>3</sup> /s   | Input Register | Floating Point Register (1 of 2) |          |
| 30116            | Flow Rate - ft <sup>3</sup> /s   | Input Register | Floating Point Register (2 of 2) |          |
| 30117            | Flow Rate - ft <sup>3</sup> /hr  | Input Register | Floating Point Register (1 of 2) |          |
| 30118            | Flow Rate - ft <sup>3</sup> /hr  | Input Register | Floating Point Register (2 of 2) |          |

6.4 MODBUS MEMORY MAP (CONTINUED)

| Register Address | Description   | Register Type  | Register Type                    | Comments                  |
|------------------|---|----------------|----------------------------------|---------------------------|
| 30119            | Flow Rate - ft <sup>3</sup> /day                      | Input Register | Floating Point Register (1 of 2) |                           |
| 30120            | Flow Rate - ft <sup>3</sup> /day                      | Input Register | Floating Point Register (2 of 2) |                           |
| 30121            | Flow Rate - USMG/sec                                  | Input Register | Floating Point Register (1 of 2) | USMG = US Million Gallons |
| 30122            | Flow Rate - USMG/sec                                  | Input Register | Floating Point Register (2 of 2) | USMG = US Million Gallons |
| 30123            | Flow Rate - USMG/min                                  | Input Register | Floating Point Register (1 of 2) | USMG = US Million Gallons |
| 30124            | Flow Rate - USMG/min                                  | Input Register | Floating Point Register (2 of 2) | USMG = US Million Gallons |
| 30125            | Flow Rate - USMG/hr                                   | Input Register | Floating Point Register (1 of 2) | USMG = US Million Gallons |
| 30126            | Flow Rate - USMG/hr                                   | Input Register | Floating Point Register (2 of 2) | USMG = US Million Gallons |
| 30127            | Flow Rate - USMG/day                                  | Input Register | Floating Point Register (1 of 2) | USMG = US Million Gallons |
| 30128            | Flow Rate - USMG/day                                  | Input Register | Floating Point Register (2 of 2) | USMG = US Million Gallons |
| 30129            | Flow Rate - L/min                                     | Input Register | Floating Point Register (1 of 2) |                           |
| 30130            | Flow Rate - L/min                                     | Input Register | Floating Point Register (2 of 2) |                           |
| 30131            | Last 24 Hour Average Flow Rate - GPM (USG/min)        | Input Register | Floating Point Register (1 of 2) |                           |
| 30132            | Last 24 Hour Average Flow Rate - GPM (USG/min)        | Input Register | Floating Point Register (2 of 2) |                           |
| 30133            | Last 24 Hour Average Flow Rate - L/sec                | Input Register | Floating Point Register (1 of 2) |                           |
| 30134            | Last 24 Hour Average Flow Rate - L/ssec               | Input Register | Floating Point Register (2 of 2) |                           |
| 30135            | Last 24 Hour Average Flow Rate - ft <sup>3</sup> /min | Input Register | Floating Point Register (1 of 2) |                           |
| 30136            | Last 24 Hour Average Flow Rate - ft <sup>3</sup> /min | Input Register | Floating Point Register (2 of 2) |                           |
| 30137            | Last 24 Hour Average Flow Rate - m <sup>3</sup> /hr   | Input Register | Floating Point Register (1 of 2) |                           |
| 30138            | Last 24 Hour Average Flow Rate - m <sup>3</sup> /hr   | Input Register | Floating Point Register (2 of 2) |                           |
| 30139            | Last 24 Hour Average Flow Rate - USG/sec              | Input Register | Floating Point Register (1 of 2) |                           |
| 30140            | Last 24 Hour Average Flow Rate - USG/sec              | Input Register | Floating Point Register (2 of 2) |                           |

6.4 MODBUS MEMORY MAP (CONTINUED)

| Register Address | Description   | Register Type  | Register Type                    | Comments                  |
|------------------|---|----------------|----------------------------------|---------------------------|
| 30141            | Last 24 Hour Average Flow Rate - USG/hr               | Input Register | Floating Point Register (1 of 2) |                           |
| 30142            | Last 24 Hour Average Flow Rate - USG/hr               | Input Register | Floating Point Register (2 of 2) |                           |
| 30143            | Last 24 Hour Average Flow Rate - USG/day              | Input Register | Floating Point Register (1 of 2) |                           |
| 30144            | Last 24 Hour Average Flow Rate - USG/day              | Input Register | Floating Point Register (2 of 2) |                           |
| 30145            | Last 24 Hour Average Flow Rate - ft <sup>3</sup> /s   | Input Register | Floating Point Register (1 of 2) |                           |
| 30146            | Last 24 Hour Average Flow Rate - ft <sup>3</sup> /s   | Input Register | Floating Point Register (2 of 2) |                           |
| 30147            | Last 24 Hour Average Flow Rate - ft <sup>3</sup> /hr  | Input Register | Floating Point Register (1 of 2) |                           |
| 30148            | Last 24 Hour Average Flow Rate - ft <sup>3</sup> /hr  | Input Register | Floating Point Register (2 of 2) |                           |
| 30149            | Last 24 Hour Average Flow Rate - ft <sup>3</sup> /day | Input Register | Floating Point Register (1 of 2) |                           |
| 30150            | Last 24 Hour Average Flow Rate - ft <sup>3</sup> /day | Input Register | Floating Point Register (2 of 2) |                           |
| 30151            | Last 24 Hour Average Flow Rate - USMG/sec             | Input Register | Floating Point Register (1 of 2) | USMG = US Million Gallons |
| 30152            | Last 24 Hour Average Flow Rate - USMG/sec             | Input Register | Floating Point Register (2 of 2) | USMG = US Million Gallons |
| 30153            | Last 24 Hour Average Flow Rate - USMG/min             | Input Register | Floating Point Register (1 of 2) | USMG = US Million Gallons |
| 30154            | Last 24 Hour Average Flow Rate - USMG/min             | Input Register | Floating Point Register (2 of 2) | USMG = US Million Gallons |
| 30155            | Last 24 Hour Average Flow Rate - USMG/hr              | Input Register | Floating Point Register (1 of 2) | USMG = US Million Gallons |
| 30156            | Last 24 Hour Average Flow Rate - USMG/hr              | Input Register | Floating Point Register (2 of 2) | USMG = US Million Gallons |
| 30157            | Last 24 Hour Average Flow Rate - USMG/day             | Input Register | Floating Point Register (1 of 2) | USMG = US Million Gallons |
| 30158            | Last 24 Hour Average Flow Rate - USMG/day             | Input Register | Floating Point Register (2 of 2) | USMG = US Million Gallons |
| 30159            | Last 24 Hour Average Flow Rate - L/min                | Input Register | Floating Point Register (1 of 2) |                           |
| 30160            | Last 24 Hour Average Flow Rate - L/min                | Input Register | Floating Point Register (2 of 2) |                           |
| 30301            | Volume Total - Gallons                                | Input Register | Floating Point Register (1 of 2) | Single mode for Onicon    |
| 30302            | Volume Total - Gallons                                | Input Register | Floating Point Register (2 of 2) |                           |

6.4 MODBUS MEMORY MAP (CONTINUED)

| Register Address | Description                      | Register Type  | Register Type                    | Comments   |
|------------------|----------------------------------|----------------|----------------------------------|--|
| 30303            | Volume Total - Liters            | Input Register | Floating Point Register (1 of 2) |  |
| 30304            | Volume Total - Liters            | Input Register | Floating Point Register (2 of 2) |  |
| 30305            | Volume Total - ft <sup>3</sup>   | Input Register | Floating Point Register (1 of 2) |  |
| 30306            | Volume Total - ft <sup>3</sup>   | Input Register | Floating Point Register (2 of 2) |  |
| 30307            | Volume Total - m <sup>3</sup>    | Input Register | Floating Point Register (1 of 2) |  |
| 30308            | Volume Total - m <sup>3</sup>    | Input Register | Floating Point Register (2 of 2) |  |
| 30901            | Signal Strength - %              | Input Register | Integer                          | 0-100  |
| 30902            | Sensor A Echo Confidence - %     | Input Register | Integer                          | 0-100  |
| 30903            | Sensor B Echo Confidence - %     | Input Register | Integer                          | 0-100  |
| 30902            | Run Hours                        | Input Register | Floating Point Register (1 of 2) | Resolution to tenths of an hour?   |
| 39003            | Run Hours                        | Input Register | Floating Point Register (2 of 2) | Resolution to tenths of an hour?   |
| 30919            | Adjusted Speed of Sound - ft/sec | Input Register | Floating Point Register (1 of 2) |  |
| 30920            | Adjusted Speed of Sound - ft/sec | Input Register | Floating Point Register (2 of 2) |  |
| 30921            | Adjusted Speed of Sound - m/sec  | Input Register | Floating Point Register (1 of 2) |  |
| 30922            | Adjusted Speed of Sound - m/sec  | Input Register | Floating Point Register (2 of 2) |  |
| 30923            | Sensor A Status                  | Input Register | Index (0-9)                      | Sensor Good<br>Sensor Echo Too Close<br>Sensor Echo Loss<br>Sensor Open<br>Sensor Short<br>Sensor Check Calib<br>Sensor Relay Fault<br>Sensor System Fault<br>Sensor Check Sensor (PSL)<br>Sensor Not Tracking (PSL) |

6.4 MODBUS MEMORY MAP (CONTINUED)

| Register Address | Description     | Register Type  | Register Type                    | Comments   |
|------------------|-----------------|----------------|----------------------------------|--|
| 30922            | Sensor B Status | Input Register | Index (0-9)                      | Sensor Good<br>Sensor Echo Too Close<br>Sensor Echo Loss<br>Sensor Open<br>Sensor Short<br>Sensor Check Calib<br>Sensor Relay Fault<br>Sensor System Fault<br>Sensor Check Sensor (PSL)<br>Sensor Not Tracking (PSL) |
| 30925            | Logging Status  | Input Register | Index (0-2)                      | Stopped<br>Active<br>Full  |
| 30926            | Logging Used    | Input Register | Floating Point Register (1 of 2) |  |
| 30927            | Logging Used    | Input Register | Floating Point Register (2 of 2) |  |
| 30947            | Velocity Units  | Input Register | Index (0 to 1)                   | ft/s<br>m/s<br>(ONICON Only)   |
| 30948            | Flow Units      | Input Register | Index (0 to 3)                   | GPM<br>L/s<br>ft <sup>3</sup> /m<br>m <sup>3</sup> /h<br>(ONICON Only)   |
| 30949            | Linear Units    | Input Register | Index (0 to 3)                   | Feet<br>Inches<br>Millimeters<br>Meters  |
| 30950            | Volume Units    | Input Register | Index (0 to 7)                   | Cubic Feet<br>US Gallons<br>US Million Gallons<br>Imperial Gallons<br>Imperial Million Gallons<br>Cubic Meters<br>Litre<br>Barrel  |
| 30951            | Time Units      | Input Register | Index (0 to 3)                   | Second<br>Minute<br>Hour<br>Day  |

**6.4 MODBUS MEMORY MAP (CONTINUED)**

| Register Address | Description       | Register Type    | Register Type              | Comments                              |
|------------------|-------------------|------------------|----------------------------|---------------------------------------|
| 40001            | Dampening - %     | Holding Register | Integer                    | 0-100                                 |
| 40002            | Min Flow (Cutoff) | Holding Register | Floating Point<br>(1 of 2) | Units match those programmed in meter |
| 40003            | Min Flow (Cutoff) | Holding Register | Floating Point<br>(2 of 2) | Units match those programmed in meter |
| 40004            | Signal Cutoff - % | Holding Register | Integer                    | 0-100                                 |
| 40005            | LOE Time          | Holding Register | Integer                    | 0-99                                  |

**6.5 REPORT SLAVE ID FUNCTION CODE**

The MODBUS implementation of the F-4300 supports the use of function code 17, Report Slave ID.

When a message is sent to the F-4300 requesting to report the slave ID, the following information is returned after converting the HEX meter response to ASCII:

“Transit-Time Flowmeter - XXXXXX” where XXXXXX = the serial number of the F-4300 being polled.



**SECTION 7.0: COMMISSIONING**

Please read all installation instructions carefully before proceeding. Wiring diagrams are located in an earlier section of this manual. Use the meter certificate of calibration to verify that the specified installation & operating parameters match the actual conditions at the location where the meter is installed. A worksheet for checking off these steps and recording measured values is located in section 7.3.

**7.1 HELPFUL HINTS FOR START-UP AND COMMISSIONING**

Please read these helpful hints before proceeding with the commissioning procedure on the next page.

1. ONICON flow meters are individually calibrated for a particular application. Be sure to verify the pipe size and location.
2. The ultrasonic flow sensing systems will not work with an empty pipe.
3. When measuring analog output signals, remember that current (mA) must be measured in series, while voltage is measured in parallel. If the 4-20 mA signal is already connected to a control system, you must break the connection and measure the signal in series.

**7.2 COMMISSIONING PROCEDURE**

Please read the entire procedure before proceeding. A worksheet for checking off the following steps and recording measured values provided in Section 7.3.

|    |  |  |
|----|--|--|
| 1. | Confirm that the flow meter is being installed in accordance with Sections 1.7 and 3.3 of this manual. | Confirm that the installation location is removed from any sources of strong electrical interference and that the enclosure is mounted on a vibration-free surface.<br>Confirm that the transducer signal cables are run in dedicated conduit without other signal or power cables.  |
| 2. | Confirm flow meter location.   | Confirm adequate straight pipe run to achieve desired results. Is the meter located in the correct location as required by the plans? Compare actual straight pipe upstream and downstream of the meter location to recommended distances identified in this manual. Contact ONICON to discuss specifics of your application. If straight pipe run is very short, consult ONICON PRIOR to commissioning the meter. |
| 3. | Confirm pipe size.   | Confirm that the meter is tagged for the pipe size in which it is installed. When in doubt, measure the circumference of the pipe. Pipe O.D. = (circumference / 3.14) – (insulation thickness x 2).  |
| 4. | Verify the type of fluid used in the piping system.  | Confirm that the fluid specified on the flow meter certificate of calibration matches the fluid flowing in the piping system.  |
| 5. | Confirm control system programming.  | Confirm that the control system input points are properly configured for the analog output range, pulse scale factor and/or relay output function identified on the calibration certificate & meter tag.   |
| 6. | Confirm connection to the correct ONICON display or BTU meter (if ordered).                            | Confirm that the flow meter serial number matches the ONICON display or BTU meter serial number (when ordered together).   |
| 7. | Verify output signal wiring.   | Verify that the wiring is correct as shown in this manual and/or the additional wiring diagram provided with the ONICON display or BTU meter. If in doubt, contact ONICON for assistance before proceeding further.  |
| 8. | Confirm correct supply voltage.  | Verify that the supply voltage is within specified limits. The F-4300 could have been ordered with a low voltage or high voltage board.  |

The following steps require flow in the pipe. Flow signal readings should be taken while holding the flow rate constant, if possible. Otherwise, take the various output readings as quickly as possible.

**7.2 COMMISSIONING PROCEDURE (Continued)**

|                                |  |   |
|--------------------------------|--|---|
| 9.                             | Record the information shown on the flow meter display.  | Record readings shown for: Flow rate and Flow total   |
| 10.                            | Measure and record analog or pulse outputs.<br><br>Current Output:<br><br>Scaled Relay Output:     | Refer to flow meter wiring diagram for the various outputs based on your particular installation. Use the following formulas to calculate flow rate from measured analog signals:<br><br>$\text{GPM} = \frac{(\text{measured current in mA} - 4) \times \text{Full Scale Analog Flow Rate}}{16}$ or,<br><br>$\text{GPM} = \frac{\text{measured voltage}}{5} \times \text{Full Scale Analog Flow Rate}$<br>Each contact closure = unit volume identified as "Scale Factor." (Measure and record time interval between contact closures.) |
| 11.                            | Compare various output signals to each other and to the flow rate displayed by the control system. | Compare the flow rate calculated in step 10 to meter display and to the flow rate indicated by the control system. Refer to the troubleshooting section of this manual when readings are inconsistent.  |
| End of standard commissioning. |  |   |

**7.3 COMMISSIONING WORKSHEET**

Please read all installation instructions carefully prior to proceeding with these steps. Use the following worksheet for checking off the commissioning steps and recording measured values. The following steps require flow in the pipe. Flow signal readings should be taken while holding the flow rate constant, if possible. Otherwise, take the various output readings as quickly as possible.

| STEP | TEST/MEASUREMENT  | S/N:   | S/N:   | S/N:   | S/N:   |
|------|---|--|--|--|--|
| 1.   | Site selection/<br>location OK:   |  |  |  |  |
| 2.   | Straight run OK:  |  |  |  |  |
| 3.   | Measured pipe size:   |  |  |  |  |
| 4.   | Record fluid type:  |  |  |  |  |
| 5.   | Control system<br>programming OK:   |  |  |  |  |
| 6.   | Record BTU meter /<br>display S/N:  |  |  |  |  |
| 7.   | Signal & transducer<br>wiring Ok:   |  |  |  |  |
| 8.   | Record measured<br>supply voltage:  |  |  |  |  |
| 9.   | Record the<br>displayed data:   | Rate _____<br>Total _____<br>Signal Strength _____ | Rate _____<br>Total _____<br>Signal Strength _____ | Rate _____<br>Total _____<br>Signal Strength _____ | Rate _____<br>Total _____<br>Signal Strength _____ |
| 10.  | Analog or pulse<br>output(s)<br>4-20 mA signal:<br>Scaled output interval:<br>Calculated flow rate: | _____ mA<br>_____ VDC<br>_____ GPM                 | _____ mA<br>_____ VDC<br>_____ GPM                 | _____ mA<br>_____ VDC<br>_____ GPM                 | _____ mA<br>_____ VDC<br>_____ GPM                 |
| 11.  | Flow rate displayed<br>by control system.   | _____ GPM  | _____ GPM  | _____ GPM  | _____ GPM  |

**SECTION 8.0: TROUBLESHOOTING**

| <b>POSSIBLE CAUSES:</b>  | <b>CORRECTIVE ACTION:</b>   |
|--|---|
| <b>METER READING WHEN THERE IS NO FLOW?</b>  |   |
| Erratic measurement (set damping to 0% to check) due to electrical noise or poor signal quality. | <ul style="list-style-type: none"> <li>• Set Calibration / Damping to 5% with zero flow use Setup / Tare function.</li> <li>• Ensure triax cable shield is properly connected to ground.</li> <li>• Ensure correct power input ground connection.</li> <li>• Double-check sensor separation distance and contact ONICON for further assistance.</li> <li>• Adjust Calibration Menu / Min Flow setting.</li> </ul> |
| Variable speed drive interference  | <ul style="list-style-type: none"> <li>• Follow drive manufacturers wiring and grounding instructions.</li> <li>• Relocate flow meter electronics, sensor and wiring away from VSD.</li> </ul>  |
| Sensor cable connections incorrect or loose  | <ul style="list-style-type: none"> <li>• Refer to connections diagram. Disconnect and reconnect sensor cables ensuring that cable is properly inserted into terminals and tightened.</li> </ul>   |
| <b>METER READING LOWER THAN EXPECTED?</b>  |   |
| Calibration Error  | <ul style="list-style-type: none"> <li>• Review calibration menu. Pipe dimensions and fluid selection/fluid velocity.</li> </ul>  |
| Lower flow rate than expected  | <ul style="list-style-type: none"> <li>• Investigate pump/valves. Compare velocity with alternate instrument.</li> </ul>  |
| Erratic measurement (set damping to 0% to check) due to electrical noise or poor signal quality. | <ul style="list-style-type: none"> <li>• Ensure triax cable sensor shield is properly grounded.</li> <li>• Ensure correct power input ground connection.</li> <li>• Double-check sensor separation distance and contact ONICON for further assistance.</li> </ul>   |
| <b>NO ECHO INDICATION ICON: NO ECHO</b>  |   |
| Sensor Connections   | <ul style="list-style-type: none"> <li>• Ensure triax cable sensor shield is properly grounded.</li> <li>• Ensure triax cable is connected to transducers.</li> </ul>   |
| Sensors not mounted to pipe or mounted improperly  | <ul style="list-style-type: none"> <li>• Apply coupling compound and mount sensors to pipe with proper sensor spacing.</li> </ul>   |
| Empty pipe or partially filled   | <ul style="list-style-type: none"> <li>• Pipe must be fluid filled and acoustically transparent in order to obtain echoes.</li> </ul>   |
| Coupling compound washed out, or sensor loose on pipe.   | <ul style="list-style-type: none"> <li>• Remount sensor.</li> <li>• Use acoustic coupling compound ultrasonic couplant.</li> </ul>  |
| <b>METER READING HIGHER THAN EXPECTED?</b>   |   |
| Calibration Error  | <ul style="list-style-type: none"> <li>• Review calibration menu. Pipe dimensions and fluid selection/fluid velocity.</li> </ul>  |
| Higher flow rate than expected   | <ul style="list-style-type: none"> <li>• Investigate pump/valves. Compare velocity with alternate instrument.</li> </ul>  |
| Erratic measurement (set damping to 0% to check) due to electrical noise or poor signal quality. | <ul style="list-style-type: none"> <li>• Ensure triax cable sensor shield is properly grounded.</li> <li>• Ensure correct power input ground connection.</li> <li>• Double-check sensor separation distance and contact ONICON for further assistance.</li> </ul>   |
| Pipe not full  | <ul style="list-style-type: none"> <li>• Verify pipe is full by mounting sensors at top of pipe and check echo icon. No echo if pipe is not full.</li> </ul>  |

**APPENDIX A - SPEED OF SOUND IN PURE WATER TABLE (IMPERIAL UNITS)**

| Sonic Velocity Relative to Temperature of Pure Water |         |               |         |         |               |         |         |               |
|--|---------|---------------|---------|---------|---------------|---------|---------|---------------|
| Temp °F  | Temp °C | Velocity ft/s | Temp °F | Temp °C | Velocity ft/s | Temp °F | Temp °C | Velocity ft/s |
| 0.0  | -17.8   | 4240          | 100.0   | 37.8    | 5003          | 200.0   | 93.3    | 5080          |
| 2.0  | -16.7   | 4267          | 102.0   | 38.9    | 5010          | 202.0   | 94.4    | 5077          |
| 4.0  | -15.6   | 4293          | 104.0   | 40.0    | 5016          | 204.0   | 95.6    | 5075          |
| 6.0  | -14.4   | 4319          | 106.0   | 41.1    | 5022          | 206.0   | 96.7    | 5077          |
| 8.0  | -13.3   | 4344          | 108.0   | 42.2    | 5028          | 208.0   | 97.8    | 5069          |
| 10.0   | -12.2   | 4368          | 110.0   | 43.3    | 5033          | 210.0   | 98.9    | 5066          |
| 12.0   | 11.0    | 4392          | 112.0   | 44.4    | 5038          | 212.0   | 100.0   | 5063          |
| 14.0   | 10.0    | 4416          | 114.0   | 45.6    | 5043          | 214.0   | 101.1   | 5059          |
| 16.0   | -8.9    | 4438          | 116.0   | 46.7    | 5048          | 216.0   | 102.2   | 5056          |
| 18.0   | -7.8    | 4460          | 118.0   | 47.8    | 5052          | 218.0   | 103.3   | 5052          |
| 20.0   | -6.7    | 4482          | 120.0   | 48.9    | 5057          | 220.0   | 104.4   | 5049          |
| 22.0   | -5.6    | 4503          | 122.0   | 50.0    | 5061          | 222.0   | 105.6   | 5045          |
| 24.0   | -4.4    | 4524          | 124.0   | 51.1    | 5065          | 224.0   | 106.7   | 5041          |
| 26.8   | -3.3    | 4544          | 126.0   | 52.2    | 5068          | 226.0   | 107.8   | 5037          |
| 28.0   | -2.2    | 4563          | 128.0   | 53.3    | 5072          | 228.0   | 108.9   | 5033          |
| 30.0   | -1.1    | 4582          | 130.0   | 54.4    | 5075          | 230.0   | 110.0   | 5029          |
| 32.0   | 0.0     | 4601          | 132.0   | 55.6    | 5078          | 232.0   | 111.1   | 5024          |
| 34.0   | 1.1     | 4619          | 134.0   | 56.7    | 5081          | 234.0   | 112.2   | 5020          |
| 36.0   | 2.2     | 4637          | 136.0   | 57.8    | 5084          | 236.0   | 113.3   | 5015          |
| 38.0   | 3.3     | 4654          | 138.0   | 58.9    | 5086          | 238.0   | 114.4   | 5011          |
| 40.0   | 4.4     | 4671          | 140.0   | 60.0    | 5089          | 240.0   | 115.6   | 5006          |
| 42.0   | 5.6     | 4687          | 142.0   | 61.1    | 5091          | 242.0   | 116.7   | 5001          |
| 44.0   | 6.7     | 4703          | 144.0   | 62.2    | 5093          | 244.0   | 117.8   | 4996          |
| 46.0   | 7.8     | 4719          | 146.0   | 63.3    | 5094          | 246.0   | 118.9   | 4991          |
| 48.0   | 8.9     | 4734          | 148.0   | 64.4    | 5096          | 248.0   | 120.0   | 4986          |
| 50.0   | 10.0    | 4748          | 150.0   | 65.6    | 5097          | 250.0   | 121.1   | 4981          |
| 52.0   | 11.1    | 4763          | 152.0   | 66.7    | 5098          | 260.0   | 126.7   | 4944          |
| 54.0   | 12.2    | 4776          | 154.0   | 67.8    | 5099          | 270.0   | 132.2   | 4911          |
| 56.0   | 13.3    | 4790          | 156.0   | 68.9    | 5100          | 280.0   | 137.8   | 4879          |
| 58.0   | 14.4    | 4803          | 158.0   | 70.0    | 5101          | 290.0   | 143.3   | 4843          |
| 60.0   | 15.56   | 4816          | 160.0   | 71.1    | 5102          | 300.0   | 148.9   | 4806          |
| 62.0   | 16.7    | 4828          | 162.0   | 72.2    | 5102          | 310.0   | 154.4   | 4767          |
| 64.0   | 17.9    | 4840          | 164.0   | 73.3    | 5102          | 320.0   | 160.0   | 4724          |
| 66.0   | 18.9    | 4852          | 166.0   | 74.4    | 5102          | 330.0   | 165.6   | 4678          |
| 68.0   | 20.0    | 4863          | 168.0   | 75.6    | 5102          | 340.0   | 171.1   | 4633          |
| 70.0   | 21.1    | 4874          | 170.0   | 76.7    | 5102          | 350.0   | 176.7   | 4587          |
| 72.0   | 22.2    | 4885          | 172.0   | 77.8    | 5101          | 360.0   | 182.2   | 4537          |
| 74.0   | 23.3    | 4895          | 174.0   | 78.9    | 5101          | 370.0   | 187.8   | 4488          |
| 76.0   | 24.4    | 4905          | 176.0   | 80.0    | 5100          | 380.0   | 193.3   | 4439          |
| 78.0   | 25.6    | 4915          | 178.0   | 81.1    | 5099          | 390.0   | 198.9   | 4386          |
| 80.0   | 26.7    | 4925          | 180.0   | 82.2    | 5098          | 400.0   | 204.4   | 4331          |
| 82.0   | 27.8    | 4934          | 182.0   | 83.3    | 5097          | 410.0   | 210.0   | 4272          |
| 84.0   | 28.9    | 4943          | 184.0   | 84.4    | 5096          | 420.0   | 215.6   | 4209          |
| 86.0   | 30.0    | 4951          | 186.0   | 85.6    | 5094          | 430.0   | 221.1   | 4147          |
| 88.0   | 31.1    | 4959          | 188.0   | 86.7    | 5093          | 440.0   | 226.7   | 4081          |
| 90.0   | 32.2    | 4967          | 190.0   | 87.8    | 5091          | 450.0   | 232.2   | 4003          |
| 92.0   | 33.3    | 4975          | 192.0   | 88.9    | 5089          | 460.0   | 237.8   | 3937          |
| 94.0   | 34.4    | 4983          | 194.0   | 90.0    | 5087          | 470.0   | 243.3   | 3871          |
| 96.0   | 35.6    | 4990          | 196.0   | 91.1    | 5085          | 480.0   | 248.9   | 3806          |
| 98.0   | 36.7    | 4997          | 198.0   | 92.2    | 5082          | 490.0   | 254.4   | 3740          |

**APPENDIX B - SPEED OF SOUND IN PURE WATER TABLE (SI UNITS)**

| Sonic Velocity Relative to Temperature of Pure Water |        |          |             |      |          |             |       |          |
|--|--------|----------|-------------|------|----------|-------------|-------|----------|
| Temperature  |        | Velocity | Temperature |      | Velocity | Temperature |       | Velocity |
| °F   | °C     | m/s      | °F          | °C   | m/s      | °F          | °C    | m/s      |
| 0.0  | -17.8  | 1292.45  | 100.0       | 37.8 | 1525.03  | 200.0       | 93.3  | 1548.38  |
| 2.0  | -16.67 | 1300.64  | 102.0       | 38.9 | 1526.99  | 202.0       | 94.4  | 1547.60  |
| 4.0  | -15.55 | 1308.63  | 104.0       | 40.0 | 1528.86  | 204.0       | 95.6  | 1546.78  |
| 6.0  | -14.44 | 1316.44  | 106.0       | 41.1 | 1530.67  | 206.0       | 96.7  | 1547.60  |
| 8.0  | -13.33 | 1324.06  | 108.0       | 42.2 | 1532.4   | 208.0       | 97.8  | 1545.02  |
| 10.0   | -12.22 | 1331.50  | 110.0       | 43.3 | 1534.06  | 210.0       | 98.9  | 1544.08  |
| 12.0   | -11.00 | 1338.77  | 112.0       | 44.4 | 1535.64  | 212.0       | 100.0 | 1543.11  |
| 14.0   | -10.0  | 1345.86  | 114.0       | 45.6 | 1537.16  | 214.0       | 101.1 | 1542.10  |
| 16.0   | -8.89  | 1352.78  | 116.0       | 46.7 | 1538.61  | 216.0       | 102.2 | 1541.05  |
| 18.0   | -7.78  | 1359.53  | 118.0       | 47.8 | 1539.99  | 218.0       | 103.3 | 1539.97  |
| 20.0   | -6.67  | 1366.12  | 120.0       | 48.9 | 1541.30  | 220.0       | 104.4 | 1538.85  |
| 22.0   | -5.56  | 1372.55  | 122.0       | 50.0 | 1542.55  | 222.0       | 105.6 | 1537.70  |
| 24.0   | -4.44  | 1378.82  | 124.0       | 51.1 | 1543.74  | 224.0       | 106.7 | 1536.51  |
| 26.8   | -3.33  | 1384.94  | 126.0       | 52.2 | 1544.86  | 226.0       | 107.8 | 1535.29  |
| 28.0   | -2.22  | 1390.90  | 128.0       | 53.3 | 1545.91  | 228.0       | 108.9 | 1534.03  |
| 30.0   | -1.11  | 1396.72  | 130.0       | 54.4 | 1546.91  | 230.0       | 110.0 | 1532.74  |
| 32.0   | 0.0    | 1402.39  | 132.0       | 55.6 | 1547.84  | 232.0       | 111.1 | 1531.42  |
| 34.0   | 1.11   | 1407.91  | 134.0       | 56.7 | 1548.72  | 234.0       | 112.2 | 1530.06  |
| 36.0   | 2.22   | 1413.30  | 136.0       | 57.8 | 1549.53  | 236.0       | 113.3 | 1528.67  |
| 38.0   | 3.33   | 1418.55  | 138.0       | 58.9 | 1550.29  | 238.0       | 114.4 | 1527.26  |
| 40.0   | 4.44   | 1423.66  | 140.0       | 60.0 | 1550.99  | 240.0       | 115.6 | 1525.81  |
| 42.0   | 5.56   | 1428.64  | 142.0       | 61.1 | 1551.63  | 242.0       | 116.7 | 1524.33  |
| 44.0   | 6.67   | 1433.48  | 144.0       | 62.2 | 1552.21  | 244.0       | 117.8 | 1522.83  |
| 46.0   | 7.78   | 1438.20  | 146.0       | 63.3 | 1552.74  | 246.0       | 118.9 | 1521.29  |
| 48.0   | 8.89   | 1442.80  | 148.0       | 64.4 | 1553.22  | 248.0       | 120.0 | 1519.73  |
| 50.0   | 10.0   | 1447.27  | 150.0       | 65.6 | 1553.64  | 250.0       | 121.1 | 1518.14  |
| 52.0   | 11.11  | 1451.62  | 152.0       | 66.7 | 1554.01  | 260.0       | 126.7 | 1507.00  |
| 54.0   | 12.22  | 1455.85  | 154.0       | 67.8 | 1554.32  | 270.0       | 132.2 | 1497.00  |
| 56.0   | 13.33  | 1459.97  | 156.0       | 68.9 | 1554.59  | 280.0       | 137.8 | 1487.00  |
| 58.0   | 14.44  | 1463.97  | 158.0       | 70.0 | 1554.80  | 290.0       | 143.3 | 1476.00  |
| 60.0   | 15.56  | 1467.86  | 160.0       | 71.1 | 1554.98  | 300.0       | 148.9 | 1465.00  |
| 62.0   | 16.67  | 1471.64  | 162.0       | 72.2 | 1555.07  | 310.0       | 154.4 | 1453.00  |
| 64.0   | 17.79  | 1475.31  | 164.0       | 73.3 | 1555.13  | 320.0       | 160.0 | 1440.00  |
| 66.0   | 18.89  | 1478.88  | 166.0       | 74.4 | 1555.15  | 330.0       | 165.6 | 1426.00  |
| 68.0   | 20.0   | 1482.34  | 168.0       | 75.6 | 1555.11  | 340.0       | 171.1 | 1412.00  |
| 70.0   | 21.1   | 1485.70  | 170.0       | 76.7 | 1555.03  | 350.0       | 176.7 | 1398.00  |
| 72.0   | 22.2   | 1488.96  | 172.0       | 77.8 | 1554.90  | 360.0       | 182.2 | 1383.00  |
| 74.0   | 23.3   | 1492.13  | 174.0       | 78.9 | 1554.72  | 370.0       | 187.8 | 1368.00  |
| 76.0   | 24.4   | 1495.19  | 176.0       | 80.0 | 1554.49  | 380.0       | 193.3 | 1353.00  |
| 78.0   | 25.6   | 1498.16  | 178.0       | 81.1 | 1554.22  | 390.0       | 198.9 | 1337.00  |
| 80.0   | 26.7   | 1501.04  | 180.0       | 82.2 | 1553.91  | 400.0       | 204.4 | 1320.00  |
| 82.0   | 27.8   | 1503.82  | 182.0       | 83.3 | 1553.55  | 410.0       | 210.0 | 1302.00  |
| 84.0   | 28.9   | 1506.52  | 184.0       | 84.4 | 1553.14  | 420.0       | 215.6 | 1283.00  |
| 86.0   | 30.0   | 1509.13  | 186.0       | 85.6 | 1552.70  | 430.0       | 221.1 | 1264.00  |
| 88.0   | 31.1   | 1511.65  | 188.0       | 86.7 | 1552.21  | 440.0       | 226.7 | 1244.00  |
| 90.0   | 32.2   | 1514.08  | 190.0       | 87.8 | 1551.67  | 450.0       | 232.2 | 1220.00  |
| 92.0   | 33.3   | 1516.44  | 192.0       | 88.9 | 1551.10  | 460.0       | 237.8 | 1200.00  |
| 94.0   | 34.4   | 1518.70  | 194.0       | 90.0 | 1550.48  | 470.0       | 243.3 | 1180.00  |
| 96.0   | 35.6   | 1520.89  | 196.0       | 91.1 | 1549.82  | 480.0       | 248.9 | 1160.00  |
| 98.0   | 36.7   | 1523.00  | 198.0       | 92.2 | 1549.12  | 490.0       | 254.4 | 1140.00  |

**APPENDIX C - SPEED OF SOUND IN GLYCOL WATER TABLE**

| GLYCOL TYPE      | PERCENT GLYCOL | SPEED OF SOUND (ft/s) | SPEED OF SOUND (m/s) |
|------------------|----------------|-----------------------|----------------------|
| PROPYLENE GLYCOL | 10             | 5052                  | 1540                 |
| PROPYLENE GLYCOL | 15             | 5167                  | 1575                 |
| PROPYLENE GLYCOL | 20             | 5282                  | 1610                 |
| PROPYLENE GLYCOL | 25             | 5364                  | 1635                 |
| PROPYLENE GLYCOL | 28             | 5413                  | 1650                 |
| PROPYLENE GLYCOL | 30             | 5446                  | 1660                 |
| PROPYLENE GLYCOL | 31             | 5449                  | 1661                 |
| PROPYLENE GLYCOL | 32             | 5456                  | 1663                 |
| PROPYLENE GLYCOL | 33             | 5463                  | 1665                 |
| PROPYLENE GLYCOL | 34             | 5466                  | 1666                 |
| PROPYLENE GLYCOL | 35             | 5472                  | 1668                 |
| PROPYLENE GLYCOL | 36             | 5476                  | 1669                 |
| PROPYLENE GLYCOL | 37             | 5482                  | 1671                 |
| PROPYLENE GLYCOL | 38             | 5485                  | 1672                 |
| PROPYLENE GLYCOL | 39             | 5492                  | 1674                 |
| PROPYLENE GLYCOL | 40             | 5495                  | 1675                 |
| PROPYLENE GLYCOL | 50             | 5545                  | 1690                 |
| ETHYLENE GLYCOL  | 10             | 5013                  | 1528                 |
| ETHYLENE GLYCOL  | 15             | 5089                  | 1551                 |
| ETHYLENE GLYCOL  | 20             | 5167                  | 1575                 |
| ETHYLENE GLYCOL  | 23             | 5236                  | 1596                 |
| ETHYLENE GLYCOL  | 25             | 5282                  | 1610                 |
| ETHYLENE GLYCOL  | 30             | 5348                  | 1630                 |
| ETHYLENE GLYCOL  | 31             | 5354                  | 1632                 |
| ETHYLENE GLYCOL  | 32             | 5361                  | 1634                 |
| ETHYLENE GLYCOL  | 33             | 5367                  | 1636                 |
| ETHYLENE GLYCOL  | 34             | 5374                  | 1638                 |
| ETHYLENE GLYCOL  | 35             | 5381                  | 1640                 |
| ETHYLENE GLYCOL  | 36             | 5394                  | 1644                 |
| ETHYLENE GLYCOL  | 37             | 5407                  | 1648                 |
| ETHYLENE GLYCOL  | 38             | 5420                  | 1652                 |
| ETHYLENE GLYCOL  | 39             | 5433                  | 1656                 |
| ETHYLENE GLYCOL  | 40             | 5446                  | 1660                 |
| ETHYLENE GLYCOL  | 50             | 5528                  | 1685                 |

APPENDIX D - PIPE CHARTS

**IMPORTANT NOTE**

Not all pipe types allowed in programming have charts below. Pipe dimensions will need to be acquired from pipe markings or the pipe manufacturer in such cases.

**Carbon Steel & PVC Pipe**

| Pipe Size | Pipe O.D. | Standard Schedule 40 |      | Extra Heavy Schedule 80 |      | Dbl. Extra Heavy |       | Schedule 10 |      | Schedule 20 |      | Schedule 30 |      | Schedule 40 |      |
|-----------|-----------|----------------------|------|-------------------------|------|------------------|-------|-------------|------|-------------|------|-------------|------|-------------|------|
|           |           | I.D.                 | WALL | I.D.                    | WALL | I.D.             | WALL  | I.D.        | WALL | I.D.        | WALL | I.D.        | WALL | I.D.        | WALL |
| 1/2       | .840      | .622                 | .109 | .546                    | .147 | .252             | .294  |             |      |             |      |             |      | .622        | .109 |
| 3/4       | 1.050     | .824                 | .113 | .742                    | .154 | .434             | .308  |             |      |             |      |             |      | .824        | .113 |
| 1         | 1.315     | 1.049                | .133 | .957                    | .179 | .599             | .358  |             |      |             |      |             |      | 1.049       | .133 |
| 1 1/4     | 1.660     | 1.380                | .140 | 1.278                   | .191 | .896             | .382  |             |      |             |      |             |      | 1.380       | .140 |
| 1 1/2     | 1.900     | 1.610                | .145 | 1.500                   | .200 | 1.100            | .400  |             |      |             |      |             |      | 1.610       | .145 |
| 2         | 2.375     | 2.067                | .154 | 1.939                   | .218 | 1.503            | .436  |             |      |             |      |             |      | 2.067       | .154 |
| 2 1/2     | 2.875     | 2.469                | .203 | 2.323                   | .276 | 1.771            | .552  |             |      |             |      |             |      | 2.469       | .203 |
| 3         | 3.500     | 3.068                | .216 | 2.900                   | .300 | 2.300            | .600  |             |      |             |      |             |      | 3.068       | .216 |
| 3 1/2     | 4.000     | 3.548                | .226 | 3.364                   | .318 | 2.728            | .636  |             |      |             |      |             |      | 3.548       | .226 |
| 4         | 4.500     | 4.026                | .237 | 3.826                   | .337 | 3.152            | .674  |             |      |             |      |             |      | 4.026       | .237 |
| 5         | 5.563     | 5.047                | .258 | 4.813                   | .375 | 4.063            | .750  |             |      |             |      |             |      | 5.047       | .258 |
| 6         | 6.625     | 6.065                | .280 | 5.761                   | .432 | 4.897            | .864  |             |      |             |      |             |      | 6.065       | .280 |
| 8         | 8.625     | 7.981                | .322 | 7.625                   | .500 | 6.875            | .875  |             |      | 8.125       | .250 | 8.071       | .277 | 7.981       | .322 |
| 10        | 10.750    | 10.020               | .365 | 9.750                   | .500 | 8.750            | 1.000 |             |      | 10.250      | .250 | 10.136      | .307 | 10.020      | .365 |
| 12        | 12.750    | 12.000               | .375 | 11.750                  | .500 | 10.750           | 1.000 |             |      | 12.250      | .250 | 12.090      | .330 | 11.938      | .406 |
| 14        | 14.000    | 13.250               | .375 | 13.000                  | .500 |                  |       | 13.500      | .250 | 13.376      | .312 | 13.250      | .375 | 13.124      | .438 |
| 16        | 16.000    | 15.250               | .375 | 15.000                  | .500 |                  |       | 15.500      | .250 | 15.376      | .312 | 15.250      | .375 | 15.000      | .500 |
| 18        | 18.000    | 17.250               | .375 | 17.000                  | .500 |                  |       | 17.500      | .250 | 17.376      | .312 | 17.124      | .438 | 16.876      | .562 |
| 20        | 20.000    | 19.250               | .375 | 19.000                  | .500 |                  |       | 19.500      | .250 | 19.250      | .375 | 19.000      | .500 | 18.814      | .593 |
| 22        | 22.000    | 21.250               | .375 | 21.000                  | .500 |                  |       | 21.500      | .250 | 21.250      | .375 | 21.000      | .500 |             |      |
| 24        | 24.000    | 23.250               | .375 | 23.000                  | .500 |                  |       | 23.500      | .250 | 23.250      | .375 | 22.876      | .562 | 22.626      | .687 |
| 26        | 26.000    | 25.250               | .375 | 25.000                  | .500 |                  |       | 25.376      | .312 | 25.000      | .500 |             |      |             |      |
| 28        | 28.000    | 27.250               | .375 | 27.000                  | .500 |                  |       | 27.376      | .312 | 27.000      | .500 | 26.750      | .625 |             |      |
| 30        | 30.000    | 29.250               | .375 | 29.000                  | .500 |                  |       | 29.376      | .312 | 29.000      | .500 | 28.750      | .625 |             |      |
| 32        | 32.000    | 31.250               | .375 | 31.000                  | .500 |                  |       | 31.376      | .312 | 31.000      | .500 | 30.750      | .625 |             |      |
| 34        | 34.000    | 33.250               | .375 | 33.000                  | .500 |                  |       | 33.376      | .312 | 33.000      | .500 | 32.750      | .625 |             |      |
| 36        | 36.000    | 35.250               | .375 | 35.000                  | .500 |                  |       | 35.376      | .312 | 35.000      | .500 | 34.750      | .625 |             |      |
| 42        | 42.000    | 41.250               | .375 | 41.000                  | .500 |                  |       |             |      | 41.000      | .500 | 40.750      | .625 |             |      |

**Ductile Iron Pipe - Standard Classes**

| Size INCH | OUTSIDE DIA. INCH | Class 50 |       | Class 51 |       | Class 52 |       | Class 53 |       | Class 54 |       | Class 55 |       | Class 56 |       | CEMENT LINING |           |
|-----------|-------------------|----------|-------|----------|-------|----------|-------|----------|-------|----------|-------|----------|-------|----------|-------|---------------|-----------|
|           |                   | WALL     | I.D.  | WALL     | I.D.  | WALL     | I.D.  | WALL     | I.D.  | WALL     | I.D.  | WALL     | I.D.  | WALL     | I.D.  | **STD         | **DOUBLE  |
|           |                   |          |       |          |       |          |       |          |       |          |       |          |       |          |       | THICKNESS     | THICKNESS |
| 3         | 3.96              |          |       | 0.25     | 3.46  | 0.28     | 3.40  | 0.31     | 3.34  | 0.34     | 3.28  | 0.37     | 3.22  | 0.41     | 3.14  |               |           |
| 4         | 4.80              |          |       | 0.26     | 4.28  | 0.29     | 4.22  | 0.32     | 4.16  | 0.35     | 4.10  | 0.38     | 4.04  | 0.44     | 3.93  |               |           |
| 6         | 6.90              | 0.25     | 6.40  | 0.28     | 6.34  | 0.31     | 6.28  | 0.34     | 6.22  | 0.37     | 6.16  | 0.40     | 6.10  | 0.43     | 6.04  | .125          | .250      |
| 8         | 9.05              | 0.27     | 8.51  | 0.30     | 8.45  | 0.33     | 8.39  | 0.36     | 8.33  | 0.39     | 8.27  | 0.42     | 8.21  | 0.45     | 8.15  |               |           |
| 10        | 11.10             | 0.39     | 10.32 | 0.32     | 10.46 | 0.35     | 10.40 | 0.38     | 10.34 | 0.41     | 10.28 | 0.44     | 10.22 | 0.47     | 10.16 |               |           |
| 12        | 13.20             | 0.31     | 12.58 | 0.34     | 12.52 | 0.37     | 12.46 | 0.40     | 12.40 | 0.43     | 12.34 | 0.46     | 12.28 | 0.49     | 12.22 |               |           |
| 14        | 15.30             | 0.33     | 14.64 | 0.36     | 14.58 | 0.39     | 14.52 | 0.42     | 14.46 | 0.45     | 14.40 | 0.48     | 14.34 | 0.51     | 14.28 |               |           |
| 16        | 17.40             | 0.34     | 16.72 | 0.37     | 16.66 | 0.40     | 16.60 | 0.43     | 16.54 | 0.46     | 16.48 | 0.49     | 16.42 | 0.52     | 16.36 |               |           |
| 18        | 19.50             | 0.35     | 18.80 | 0.38     | 18.74 | 0.41     | 18.68 | 0.44     | 18.62 | 0.47     | 18.56 | 0.50     | 18.50 | 0.53     | 18.44 | .1875         | .375      |
| 20        | 21.60             | 0.36     | 20.88 | 0.39     | 20.82 | 0.42     | 20.76 | 0.45     | 20.70 | 0.48     | 20.64 | 0.51     | 20.58 | 0.54     | 20.52 |               |           |
| 24        | 25.80             | 0.38     | 25.04 | 0.41     | 24.98 | 0.44     | 24.92 | 0.47     | 24.86 | 0.50     | 24.80 | 0.53     | 24.74 | 0.56     | 24.68 |               |           |
| 30        | 32.00             | 0.39     | 31.22 | 0.43     | 31.14 | 0.47     | 31.06 | 0.51     | 30.98 | 0.55     | 30.90 | 0.59     | 30.82 | 0.63     | 30.74 |               |           |
| 36        | 38.30             | 0.43     | 37.44 | 0.48     | 37.34 | 0.62     | 37.06 | 0.58     | 37.14 | 0.63     | 37.04 | 0.68     | 36.94 | 0.73     | 36.84 |               |           |
| 42        | 44.50             | 0.47     | 43.56 | 0.53     | 43.44 | 0.59     | 43.32 | 0.65     | 43.20 | 0.71     | 43.08 | 0.77     | 42.96 | 0.83     | 42.84 | .250          | .500      |
| 48        | 50.80             | 0.51     | 49.78 | 0.58     | 49.64 | 0.65     | 49.50 | 0.72     | 49.36 | 0.79     | 49.22 | 0.86     | 49.08 | 0.93     | 48.94 |               |           |
| 54        | 57.10             | 0.57     | 55.96 | 0.65     | 55.80 | 0.73     | 55.64 | 0.81     | 55.48 | 0.89     | 55.32 | 0.97     | 55.16 | 1.05     | 55.00 |               |           |

\*\*REDUCE I.D. BY DIMENSION SHOWN

APPENDIX D - PIPE CHARTS (Continued)

Stainless Steel, Hastelloy "C" & Titanium Pipe

| Pipe Size | Pipe O.D. | Schedule 5 S (a) |      | Schedule 10 S (a) |      | Schedule 40 S |      | Schedule 80 S |      |
|-----------|-----------|------------------|------|-------------------|------|---------------|------|---------------|------|
|           |           | I.D.             | WALL | I.D.              | WALL | I.D.          | WALL | I.D.          | WALL |
| ½         | .840      | .710             | .065 | .674              | .083 | .622          | .109 | .546          | .147 |
| ¾         | 1.050     | .920             | .065 | .884              | .083 | .824          | .113 | .742          | .154 |
| 1         | 1.315     | 1.185            | .065 | 1.097             | .109 | 1.049         | .133 | .957          | .179 |
| 1¼        | 1.660     | 1.530            | .065 | 1.442             | .109 | 1.380         | .140 | 1.278         | .191 |
| 1½        | 1.900     | 1.770            | .065 | 1.682             | .109 | 1.610         | .145 | 1.500         | .200 |
| 2         | 2.375     | 2.245            | .065 | 2.157             | .109 | 2.067         | .154 | 1.939         | .218 |
| 2½        | 2.875     | 2.709            | .083 | 2.635             | .120 | 2.469         | .203 | 2.323         | .276 |
| 3         | 3.500     | 3.334            | .083 | 3.260             | .120 | 3.068         | .216 | 2.900         | .300 |
| 3½        | 4.000     | 3.834            | .083 | 3.760             | .120 | 3.548         | .226 | 3.364         | .318 |
| 4         | 4.500     | 4.334            | .083 | 4.260             | .120 | 4.026         | .237 | 3.826         | .337 |
| 5         | 5.563     | 5.345            | .109 | 5.295             | .134 | 5.047         | .258 | 4.813         | .375 |
| 6         | 6.625     | 6.407            | .109 | 6.357             | .134 | 6.065         | .280 | 5.761         | .432 |
| 8         | 8.625     | 8.407            | .109 | 8.329             | .148 | 7.981         | .322 | 7.625         | .500 |
| 10        | 10.750    | 10.482           | .134 | 10.420            | .165 | 10.020        | .365 | 9.750         | .500 |
| 12        | 12.750    | 12.438           | .156 | 12.390            | .180 | 12.000        | .375 | 11.750        | .500 |
| 14        | 14.000    | 13.688           | .156 | 13.624            | .188 |               |      |               |      |
| 16        | 16.000    | 15.670           | .165 | 15.624            | .188 |               |      |               |      |
| 18        | 18.000    | 17.670           | .165 | 17.624            | .188 |               |      |               |      |
| 20        | 20.000    | 19.634           | .188 | 19.564            | .218 |               |      |               |      |
| 22        | 22.000    | 21.624           | .188 | 21.564            | .218 |               |      |               |      |
| 24        | 24.000    | 23.563           | .218 | 23.500            | .250 |               |      |               |      |

| Pipe Size | Pipe O.D. | Schedule 60 |      | Schedule 80 |       | Schedule 100 |       | Schedule 120 |       | Schedule 140 |       | Schedule 160 |       |
|-----------|-----------|-------------|------|-------------|-------|--------------|-------|--------------|-------|--------------|-------|--------------|-------|
|           |           | I.D.        | WALL | I.D.        | WALL  | I.D.         | WALL  | I.D.         | WALL  | I.D.         | WALL  | I.D.         | WALL  |
| ½         | .840      |             |      | .546        | .147  |              |       |              |       |              |       | .466         | .187  |
| ¾         | 1.050     |             |      | .742        | .154  |              |       |              |       |              |       | .614         | .218  |
| 1         | 1.315     |             |      | .957        | .179  |              |       |              |       |              |       | .815         | .250  |
| 1¼        | 1.660     |             |      | 1.278       | .191  |              |       |              |       |              |       | 1.160        | .250  |
| 1½        | 1.900     |             |      | 1.500       | .200  |              |       |              |       |              |       | 1.338        | .281  |
| 2         | 2.375     |             |      | 1.939       | .218  |              |       |              |       |              |       | 1.689        | .343  |
| 2½        | 2.875     |             |      | 2.323       | .276  |              |       |              |       |              |       | 2.125        | .375  |
| 3         | 3.500     |             |      | 2.900       | .300  |              |       |              |       |              |       | 2.624        | .438  |
| 3½        | 4.000     |             |      | 3.364       | .318  |              |       |              |       |              |       |              |       |
| 4         | 4.500     |             |      | 3.826       | .337  |              |       | 3.624        | .438  |              |       | 3.438        | .531  |
| 5         | 5.563     |             |      | 4.813       | .375  |              |       | 4.563        | .500  |              |       | 4.313        | .625  |
| 6         | 6.625     |             |      | 5.761       | .432  |              |       | 5.501        | .562  |              |       | 5.189        | .718  |
| 8         | 8.625     | 7.813       | .406 | 7.625       | .500  | 7.439        | .593  | 7.189        | .718  | 7.001        | .812  | 6.813        | .906  |
| 10        | 10.750    | 9.750       | .500 | 9.564       | .593  | 9.314        | .718  | 9.064        | .843  | 8.750        | 1.000 | 8.500        | 1.125 |
| 12        | 12.750    | 11.626      | .562 | 11.376      | .687  | 11.064       | .843  | 10.750       | 1.000 | 10.500       | 1.125 | 10.126       | 1.312 |
| 14        | 14.000    | 12.814      | .593 | 12.500      | .750  | 12.126       | .937  | 11.814       | 1.093 | 11.500       | 1.250 | 11.188       | 1.406 |
| 16        | 16.000    | 14.688      | .656 | 14.314      | .843  | 13.938       | 1.031 | 13.564       | 1.218 | 13.124       | 1.438 | 12.814       | 1.593 |
| 18        | 18.000    | 16.500      | .750 | 16.126      | .937  | 15.688       | 1.156 | 15.250       | 1.375 | 14.876       | 1.562 | 14.438       | 1.781 |
| 20        | 20.000    | 18.376      | .812 | 17.938      | 1.031 | 17.438       | 1.281 | 17.000       | 1.500 | 16.500       | 1.750 | 16.064       | 1.968 |
| 22        | 22.000    | 20.250      | .875 | 19.750      | 1.125 | 19.250       | 1.375 | 18.750       | 1.625 | 18.250       | 1.875 | 17.750       | 2.125 |
| 24        | 24.000    | 22.064      | .968 | 21.564      | 1.218 | 20.938       | 1.531 | 20.376       | 1.812 | 19.876       | 2.062 | 19.314       | 2.343 |



APPENDIX D - PIPE CHARTS (Continued)

Cast Iron Pipe - ASA Standard

| Pipe Size | Pipe O.D. | Class 50 |       | Class 100 |       | Class 150 |       | Class 200 |       | Class 250 |       | Class 300 |       | Class 350 |       |
|-----------|-----------|----------|-------|-----------|-------|-----------|-------|-----------|-------|-----------|-------|-----------|-------|-----------|-------|
|           |           | WALL     | I.D.  | WALL      | I.D.  | WALL      | I.D.  | WALL      | I.D.  | WALL      | I.D.  | WALL      | I.D.  | WALL      | I.D.  |
| 3         | 3.96      | 0.32     | 3.32  | 0.32      | 3.32  | 0.32      | 3.32  | 0.32      | 3.32  | 0.32      | 3.32  | 0.32      | 3.32  | 0.32      | 3.32  |
| 4         | 4.80      | 0.35     | 4.10  | 0.35      | 4.10  | 0.35      | 4.10  | 0.35      | 4.10  | 0.35      | 4.10  | 0.35      | 4.10  | 0.35      | 4.10  |
| 6         | 6.90      | 0.38     | 6.14  | 0.38      | 6.14  | 0.38      | 6.14  | 0.38      | 6.14  | 0.38      | 6.14  | 0.38      | 6.14  | 0.38      | 6.14  |
| 8         | 9.05      | 0.41     | 8.23  | 0.41      | 8.23  | 0.41      | 8.23  | 0.41      | 8.23  | 0.41      | 8.23  | 0.41      | 8.23  | 0.41      | 8.23  |
| 10        | 11.10     | 0.44     | 10.22 | 0.44      | 10.22 | 0.44      | 10.22 | 0.44      | 10.22 | 0.44      | 10.22 | 0.48      | 10.14 | 0.52      | 10.06 |
| 12        | 13.20     | 0.48     | 12.24 | 0.48      | 12.24 | 0.48      | 12.24 | 0.48      | 12.24 | 0.52      | 12.16 | 0.52      | 12.16 | 0.56      | 12.08 |
| 14        | 15.30     | 0.48     | 14.34 | 0.51      | 14.28 | 0.51      | 14.28 | 0.55      | 14.20 | 0.59      | 14.12 | 0.59      | 14.12 | 0.64      | 14.02 |
| 16        | 17.40     | 0.54     | 16.32 | 0.54      | 16.32 | 0.54      | 16.32 | 0.58      | 16.24 | 0.63      | 16.14 | 0.68      | 16.04 | 0.68      | 16.04 |
| 18        | 19.50     | 0.54     | 18.42 | 0.58      | 18.34 | 0.58      | 18.34 | 0.63      | 18.24 | 0.68      | 18.14 | 0.73      | 18.04 | 0.79      | 17.92 |
| 20        | 21.60     | 0.57     | 20.46 | 0.62      | 20.36 | 0.62      | 20.36 | 0.67      | 20.26 | 0.72      | 20.16 | 0.78      | 20.04 | 0.84      | 19.92 |
| 24        | 25.80     | 0.63     | 24.54 | 0.68      | 24.44 | 0.73      | 24.34 | 0.79      | 24.22 | 0.79      | 24.22 | 0.85      | 24.10 | 0.92      | 23.96 |

Cast Iron Pipe - AWWA Standard

| Pipe Size | Class A<br>100 Ft. 43 PSIG |      |       | Class B<br>200 Ft. 86 PSIG |      |       | Class C<br>300 Ft. 130 PSIG |      |       | Class D<br>400 Ft. 173 PSIG |      |       |
|-----------|----------------------------|------|-------|----------------------------|------|-------|-----------------------------|------|-------|-----------------------------|------|-------|
|           | O.D.                       | WALL | I.D.  | O.D.                       | WALL | I.D.  | O.D.                        | WALL | I.D.  | O.D.                        | WALL | I.D.  |
| 3         | 3.80                       | 0.39 | 3.02  | 3.96                       | 0.42 | 3.12  | 3.96                        | 0.45 | 3.06  | 3.96                        | 0.48 | 3.00  |
| 4         | 4.80                       | 0.42 | 3.96  | 5.00                       | 0.45 | 4.10  | 5.00                        | 0.48 | 4.04  | 5.00                        | 0.52 | 3.96  |
| 6         | 6.90                       | 0.44 | 6.02  | 7.10                       | 0.48 | 6.14  | 7.10                        | 0.51 | 6.08  | 7.10                        | 0.55 | 6.00  |
| 8         | 9.05                       | 0.46 | 8.13  | 9.05                       | 0.51 | 8.03  | 9.30                        | 0.56 | 8.18  | 9.30                        | 0.60 | 8.10  |
| 10        | 11.10                      | 0.50 | 10.10 | 11.10                      | 0.57 | 9.96  | 11.40                       | 0.62 | 10.16 | 11.40                       | 0.68 | 10.04 |
| 12        | 13.20                      | 0.54 | 12.12 | 13.20                      | 0.62 | 11.96 | 13.50                       | 0.68 | 12.14 | 13.50                       | 0.75 | 12.00 |
| 14        | 15.30                      | 0.57 | 14.16 | 15.30                      | 0.66 | 13.98 | 15.65                       | 0.74 | 14.17 | 15.65                       | 0.82 | 14.01 |
| 16        | 17.40                      | 0.60 | 16.20 | 17.40                      | 0.70 | 16.00 | 17.80                       | 0.80 | 16.20 | 17.80                       | 0.89 | 16.02 |
| 18        | 19.50                      | 0.64 | 18.22 | 19.50                      | 0.75 | 18.00 | 19.92                       | 0.87 | 18.18 | 19.92                       | 0.96 | 18.00 |
| 20        | 21.60                      | 0.67 | 20.26 | 21.60                      | 0.80 | 20.00 | 22.06                       | 0.92 | 20.22 | 22.06                       | 1.03 | 20.00 |
| 24        | 25.80                      | 0.76 | 24.28 | 25.80                      | 0.89 | 24.02 | 26.32                       | 1.04 | 24.22 | 26.32                       | 1.16 | 24.00 |
| 30        | 31.74                      | 0.88 | 29.98 | 32.00                      | 1.03 | 29.94 | 32.40                       | 1.20 | 30.00 | 32.74                       | 1.37 | 30.00 |
| 36        | 37.96                      | 0.99 | 35.98 | 38.30                      | 1.15 | 36.00 | 38.70                       | 1.36 | 39.98 | 39.16                       | 1.58 | 36.00 |
| 42        | 44.20                      | 1.10 | 42.00 | 44.50                      | 1.28 | 41.94 | 45.10                       | 1.54 | 42.02 | 45.58                       | 1.78 | 42.02 |
| 48        | 50.50                      | 1.26 | 47.98 | 50.80                      | 1.42 | 47.96 | 51.40                       | 1.71 | 47.98 | 51.98                       | 1.96 | 48.06 |
| 54        | 56.66                      | 1.35 | 53.96 | 57.10                      | 1.55 | 54.00 | 57.80                       | 1.90 | 54.00 | 58.40                       | 2.23 | 53.94 |
| 60        | 62.80                      | 1.39 | 60.02 | 63.40                      | 1.67 | 60.06 | 64.20                       | 2.00 | 60.20 | 64.82                       | 2.38 | 60.06 |
| 72        | 75.34                      | 1.62 | 72.10 | 76.00                      | 1.95 | 72.10 | 76.88                       | 2.39 | 72.10 |                             |      |       |
| 84        | 87.54                      | 1.72 | 84.10 | 88.54                      | 2.22 | 84.10 |                             |      |       |                             |      |       |

| Pipe Size | Class E<br>500 Ft. 217 PSIG |      |       | Class F<br>600 Ft. 260 PSIG |      |       | Class G<br>700 Ft. 304 PSIG |      |       | Class H<br>800 Ft. 347 PSIG |      |       |
|-----------|-----------------------------|------|-------|-----------------------------|------|-------|-----------------------------|------|-------|-----------------------------|------|-------|
|           | O.D.                        | WALL | I.D.  | O.D.                        | WALL | I.D.  | O.D.                        | WALL | I.D.  | O.D.                        | WALL | I.D.  |
| 6         | 7.22                        | 0.58 | 6.06  | 7.22                        | 0.61 | 6.00  | 7.38                        | 0.65 | 6.08  | 7.38                        | 0.69 | 6.00  |
| 8         | 9.42                        | 0.66 | 8.10  | 9.42                        | 0.71 | 8.00  | 9.60                        | 0.75 | 8.10  | 9.60                        | 0.80 | 8.00  |
| 10        | 11.60                       | 0.74 | 10.12 | 11.60                       | 0.80 | 10.00 | 11.84                       | 0.86 | 10.12 | 11.84                       | 0.92 | 10.00 |
| 12        | 13.78                       | 0.82 | 12.14 | 13.78                       | 0.89 | 12.00 | 14.08                       | 0.97 | 12.14 | 14.08                       | 1.04 | 12.00 |
| 14        | 15.98                       | 0.90 | 14.18 | 15.98                       | 0.99 | 14.00 | 16.32                       | 1.07 | 14.18 | 16.32                       | 1.16 | 14.00 |
| 16        | 18.16                       | 0.98 | 16.20 | 18.16                       | 1.08 | 16.00 | 18.54                       | 1.18 | 16.18 | 18.54                       | 1.27 | 16.00 |
| 18        | 20.34                       | 1.07 | 18.20 | 20.34                       | 1.17 | 18.00 | 20.78                       | 1.28 | 18.22 | 20.78                       | 1.39 | 18.00 |
| 20        | 22.54                       | 1.15 | 20.24 | 22.54                       | 1.27 | 20.00 | 23.02                       | 1.39 | 20.24 | 23.02                       | 1.51 | 20.00 |
| 24        | 26.90                       | 1.31 | 24.28 | 26.90                       | 1.45 | 24.00 | 27.76                       | 1.75 | 24.26 | 27.76                       | 1.88 | 24.00 |
| 30        | 33.10                       | 1.55 | 30.00 | 33.46                       | 1.73 | 30.00 |                             |      |       |                             |      |       |
| 36        | 39.60                       | 1.80 | 36.00 | 40.04                       | 2.02 | 36.00 |                             |      |       |                             |      |       |

APPENDIX D - PIPE CHARTS (Continued)

Copper Tubing

| Pipe Size | K      |        |       | L      |        |       | M      |        |       | Copper & Brass Pipe |       |       | Aluminum |       |       |
|-----------|--------|--------|-------|--------|--------|-------|--------|--------|-------|---------------------|-------|-------|----------|-------|-------|
|           | O.D.   | I.D.   | WALL  | O.D.   | I.D.   | WALL  | O.D.   | I.D.   | WALL  | O.D.                | I.D.  | WALL  | O.D.     | I.D.  | WALL  |
| ½         | 0.625  | 0.527  | 0.049 | 0.625  | 0.545  | 0.040 | 0.625  | 0.569  | 0.028 | 0.840               | 0.625 | 0.108 |          |       |       |
| ⅝         | 0.750  | 0.652  | 0.049 | 0.750  | 0.666  | 0.042 | 0.750  | 0.690  | 0.030 |                     |       |       |          |       |       |
| ¾         | 0.875  | 0.745  | 0.065 | 0.875  | 0.785  | 0.045 | 0.875  | 0.811  | 0.032 | 1.050               | 0.822 | 0.114 |          |       |       |
| 1         | 1.125  | 0.995  | 0.065 | 1.125  | 1.025  | 0.050 | 1.125  | 1.055  | 0.035 | 1.315               | 1.062 | 0.127 |          |       |       |
| 1 ¼       | 1.375  | 1.245  | 0.065 | 1.375  | 1.265  | 0.055 | 1.375  | 1.291  | 0.042 | 1.660               | 1.368 | 0.146 |          |       |       |
| 1 ½       | 1.625  | 1.481  | 0.072 | 1.625  | 1.505  | 0.060 | 1.625  | 1.527  | 0.049 | 1.900               | 1.600 | 0.150 |          |       |       |
| 2         | 2.125  | 1.959  | 0.083 | 2.125  | 1.985  | 0.070 | 2.125  | 2.009  | 0.058 | 2.375               | 2.062 | 0.157 |          |       |       |
| 2 ½       | 2.625  | 2.435  | 0.095 | 2.625  | 2.465  | 0.080 | 2.625  | 2.495  | 0.065 | 2.875               | 2.500 | 0.188 | 2.500    | 2.400 | 0.050 |
| 3         | 3.125  | 2.907  | 0.109 | 3.125  | 2.945  | 0.090 | 3.125  | 2.981  | 0.072 | 3.500               | 3.062 | 0.219 | 3.000    | 2.900 | 0.050 |
| 3 ½       | 3.625  | 3.385  | 0.120 | 3.625  | 3.425  | 0.100 | 3.625  | 3.459  | 0.083 | 4.000               | 3.500 | 0.250 |          |       |       |
| 4         | 4.125  | 3.857  | 0.134 | 4.125  | 3.905  | 0.110 | 4.125  | 3.935  | 0.095 | 4.500               | 3.935 | 0.095 | 4.000    | 4.000 | 0.250 |
| 4 ½       |        |        |       |        |        |       |        |        |       |                     |       |       | 5.000    | 4.500 | 0.250 |
| 5         | 5.125  | 4.805  | 0.160 | 5.125  | 4.875  | 0.125 | 5.125  | 4.907  | 0.109 | 5.563               | 5.063 | 0.250 | 5.000    | 4.874 | 0.063 |
| 6         | 6.125  | 5.741  | 0.192 | 6.125  | 5.845  | 0.140 | 6.125  | 5.881  | 0.122 | 6.625               | 6.125 | 0.250 | 6.000    | 5.874 | 0.063 |
| 7         |        |        |       |        |        |       |        |        |       | 7.625               | 7.062 | 0.282 | 7.000    | 6.844 | 0.078 |
| 8         | 8.125  | 7.583  | 0.271 | 8.125  | 7.725  | 0.200 | 8.125  | 7.785  | 0.170 | 8.625               | 8.000 | 0.313 | 8.000    | 7.812 | 0.094 |
| 10        | 10.125 | 9.449  | 0.338 | 10.125 | 9.625  | 0.250 | 10.125 | 9.701  | 0.212 | 10.000              | 9.812 | 0.094 |          |       |       |
| 12        | 12.125 | 11.315 | 0.405 | 12.125 | 11.565 | 0.280 | 12.125 | 11.617 | 0.254 |                     |       |       |          |       |       |



---

ONICON Incorporated • 11451 Belcher Road South • Largo, FL 33773 • USA  
(P) 727.447.6140 • (F) 727.442.5699 • [onicon.com](http://onicon.com)