

1. Extruded aluminum (6063-T5) damper frame is not less than 0.080" (2.03 mm) in thickness. Damper frame is 4" (101.6 mm) deep x 1" (25.4 mm), with mounting flanges on both sides of frame. Damper frame has a 2" (50.8 mm) mounting flange on the rear of the damper, when ordered as Extended Rear Flange install type.
2. Blades are maximum 6" (152.4 mm) deep extruded aluminum (6063-T5) air-foil profiles. All blades are symmetrically pivoted.
3. Blade seals are extruded EPDM. Frame seals are extruded silicone. Seals are secured in an integral slot within the aluminum extrusions. Blade and frame seals are mechanically fastened to prevent shrinkage and movement over the life of the damper.
4. Bearings are composed of a Celcon inner bearing - fixed around a 7/16" (11.11 mm) aluminum hexagon blade pivot pin - rotating within a polycarbonate outer bearing inserted in the frame. This eliminates action between metal-to-metal or metal-to-plastic riding surfaces.
5. Adjustable 7/16" (11.11 mm) hexagonal drive rod, U-bolt fastener, and hexagonal retaining nuts are zinc-plated steel. These provide a positive connection to blades and linkage.
6. Aluminum and corrosion-resistant zinc-plated steel linkage hardware is installed in the frame side, complete with cup-point trunnion screws for a slip-proof grip.
7. Linkage between face and bypass sections is uninterrupted, so transmission of torque (stroke) is direct and without losses, and there is no mechanism that will loosen or fail.
8. Dampers are designed for operation in temperatures ranging from -40°F (-40°C) to 212°F (100°C).
9. Leakage does not exceed 3 cfm/ft² (15.2 l/s/m²) against 1 in w.g. (0.25 kPa) static pressure differential. Tested in accordance with ANSI/AMCA Standard 500-D.
10. Dampers are custom made to required size, without blanking off free area. The blade stop is set at a fixed height and is a continuous and integral part of the top and bottom frames.
11. Dampers are available with either opposed blade action or parallel blade action.
12. Dampers are available in three install types: Installed In Duct, Flanged to Duct, and Extended Rear Flange. (See *Install Type* pages for details.)
13. Installation of dampers must be in accordance with TAMCO's current on-line installation guidelines. (Printed installation guidelines are provided with each damper shipment, however all technical information available on TAMCO's web site at www.tamcodampers.com supersedes information contained within printed versions.)
14. Intermediate structural support is required to resist applied pressure loads for dampers that consist of two or more sections in both height and width. (See *TAMCO Aluminum Damper Installation Guidelines*.)

OPTIONS FOR SP - STANDARD PROFILE:

For each option listed, replace the lines above with their corresponding lines below.

ET - ELEVATED TEMPERATURE OPTION:

(This is not a UL approved product. For UL Approved Smoke Dampers refer to Series 1000 SM Submittal Data.)

3. Blade and frame seals are extruded silicone, secured in an integral slot within the aluminum extrusions. Seals are mechanically fastened to prevent shrinkage and movement over the life of the damper.
4. Bearings are composed of a bronze oilite inner bearing - fixed around a 7/16" (11.11 mm) aluminum hexagon blade pivot pin - rotating within a bronze oilite outer bearing inserted in the frame.
6. Aluminum and corrosion-resistant zinc-plated steel linkage hardware is installed in the frame side, complete with cup-point trunnion screws for a slip-proof grip. Trunnion bearing is bronze oilite.
8. Dampers are designed for operation in temperatures ranging from -40°F (-40°C) to 300°F (149°C).

MR - MOISTURE RESISTANCE OPTION:

1. Extruded aluminum (6063-T5) damper frame is not less than 0.080" (2.03 mm) in thickness. Damper frame is 4" (101.6 mm) deep x 1" (25.4 mm), with mounting flanges on both sides of frame. Damper frame has a 2" (50.8 mm) mounting flange on the rear of the damper, when ordered as Extended Rear Flange install type. Frame is assembled using stainless steel screws.
5. Adjustable 7/16" (11.11 mm) hexagonal drive rod, U-bolt fastener, and hexagonal retaining nuts are stainless steel. These provide a positive connection to blades and linkage.
6. Aluminum and stainless steel linkage hardware is installed in the frame side, complete with cup-point trunnion screws for a slip-proof grip.

SW - SALT WATER RESISTANCE OPTION:

1. Extruded aluminum (6063-T5) damper frame is not less than 0.080" (2.03 mm) in thickness. Damper frame is 4" (101.6 mm) deep x 1" (25.4 mm), with mounting flanges on both sides of frame. Damper frame has a 2" (50.8 mm) mounting flange on the rear of the damper, when ordered as Extended Rear Flange install type. Aluminum frame is clear anodized to a minimum depth of 0.7 mil (18 microns). Frame is assembled using stainless steel screws.
2. Blades are maximum 6" (152.4 mm) deep extruded aluminum (6063-T5) air-foil profiles, clear anodized to a minimum depth of 0.7 mil (18 microns). All blades are symmetrically pivoted.
3. Blade and frame seals are extruded silicone, secured in an integral slot within the aluminum extrusions. Seals are mechanically fastened to prevent shrinkage and movement over the life of the damper.
5. Adjustable 7/16" (11.11 mm) hexagonal drive rod, U-bolt fastener, and hexagonal retaining nuts are stainless steel. These provide a positive connection to blades and linkage.
6. Clear anodized aluminum and stainless steel linkage hardware is installed in the frame side, complete with cup-point trunnion screws for a slip-proof grip.

VELOCITY VS. PRESSURE DROP

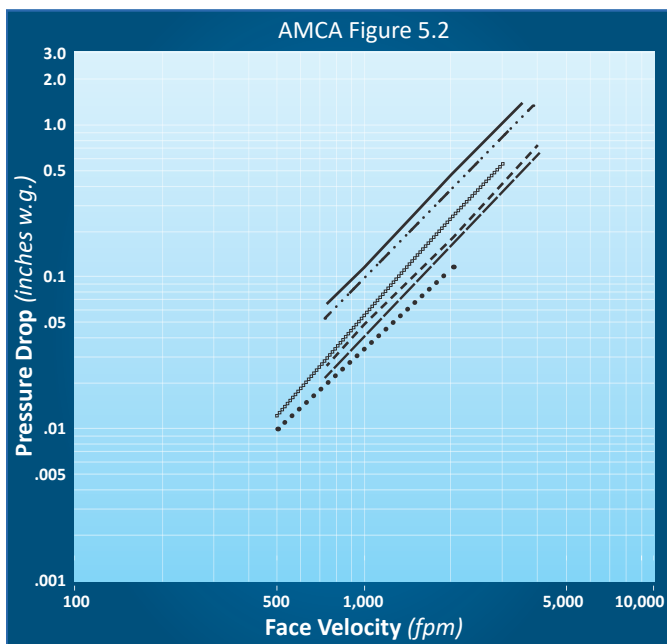

LEGEND:

12" x 12" ——— (305 mm x 305 mm)	12" x 24" - - - - - (305 mm x 610 mm)	24" x 24" - - - - (610 mm x 610 mm)
12" x 48" ——— (305 mm x 1220 mm)	36" x 36" ••••• (915 mm x 915 mm)	48" x 12" - · - · - (1220 mm x 305 mm)

FIG. 5.2 Test damper is located at the end of 5 diameters of a duct run, exhausting into an open area. Both duct and test damper are downstream from air supply.

Pressure drop values are based on Flanged to Duct install type. Pressure drop will be greater for In Duct install type dampers.

NOTE:

- > To reduce pressure drop, use Flanged to Duct or Extended Rear Flange install types for sizes under 9 ft² (83 m²).
- > Suitable for operation in breathable air environments within stated temperature range.
- > SP dampers sized for duct openings exceeding 37³/₄" (959 mm) in height are equipped with a brace at mid-height to strengthen and maintain air leakage tolerances.

BLADE DESIGN PRESSURE LIMITATIONS

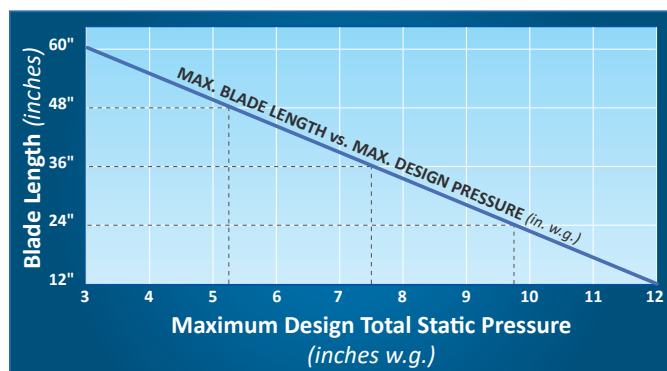

Series 1000 FB dampers with SP – Standard Profile, whose blade length exceeds the maximum design pressure, may be reconfigured to maintain a blade length compatible with the required system pressure by increasing the number of sections per damper and thereby reducing each damper section's blade length. Appropriate intermediate structural support will be required for all multiple-section damper assemblies. (Refer to line 14 of the Submittal Data and to TAMCO's Aluminum Damper Installation Guidelines.)

Example:

A single-section damper of 60" w x 36" h (1524 mm x 915 mm) at 5 in. w.g. (1.24 kPa) would need to be built in two sections of 30" w x 36" h (762 mm x 915 mm).

For additional information, refer to:

- > Series 1000, 1500 Free Area Charts
- > Face & Bypass Damper Standard Configurations
- > Aluminum Damper Torque Requirements
- > Single-Section Horizontal Jackshafts
- > Multiple-Section Horizontal Jackshafts
- > Multiple-Section Damper Jumpers
- > TAMCO Aluminum Damper Installation Guidelines

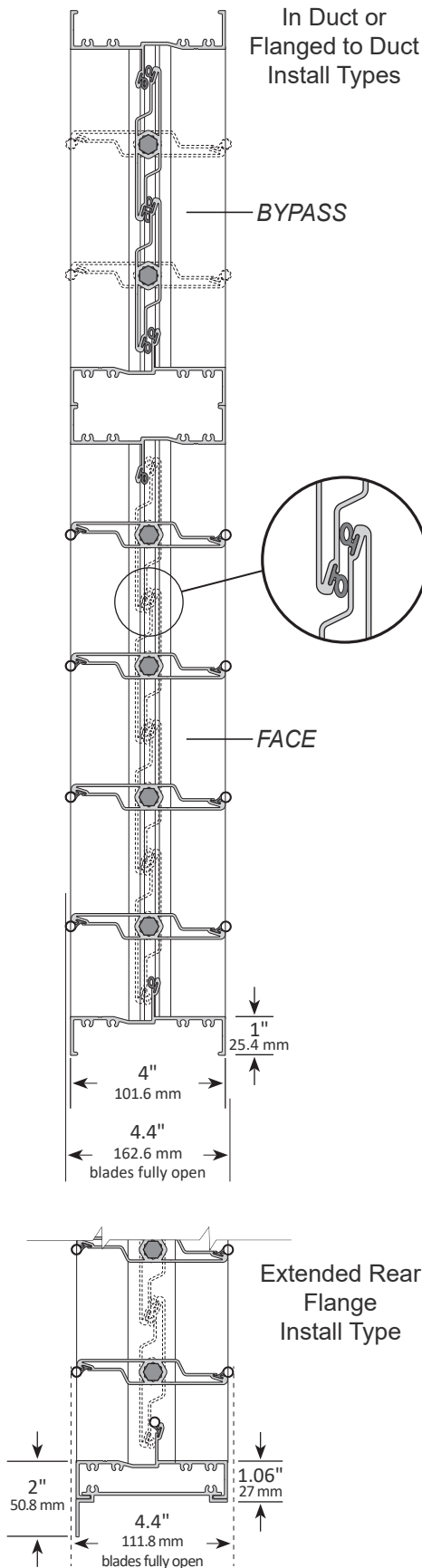

1. Extruded aluminum (6063-T5) damper frame is not less than 0.080" (2.03 mm) in thickness. Damper frame is 4" (101.6 mm) deep x 1" (25.4 mm), with mounting flanges on both sides of frame. Damper frame has a 2" (50.8 mm) mounting flange on the rear of the damper, when ordered as Extended Rear Flange install type.
2. Blades are 4" (101.6 mm) deep extruded aluminum (6063-T5) air-foil profiles, and each blade seal extends only 0.2" (5.1 mm) beyond the frame when in the full open position. All blades are symmetrically pivoted.
3. Blade seals are extruded EPDM. Frame seals are extruded silicone. Seals are secured in an integral slot within the aluminum extrusions. Blade and frame seals are mechanically fastened to prevent shrinkage and movement over the life of the damper.
4. Bearings are composed of a Celcon inner bearing - fixed around a 7/16" (11.11 mm) aluminum hexagon blade pivot pin - rotating within a polycarbonate outer bearing inserted in the frame. This eliminates action between metal-to-metal or metal-to-plastic riding surfaces.
5. Adjustable 7/16" (11.11 mm) hexagonal drive rod, U-bolt fastener, and hexagonal retaining nuts are zinc-plated steel. These provide a positive connection to blades and linkage.
6. Aluminum and corrosion-resistant zinc-plated steel linkage hardware is installed in the frame side, complete with cup-point trunnion screws for a slip-proof grip.
7. Linkage between face and bypass sections is uninterrupted, so transmission of torque (stroke) is direct and without losses, and there is no mechanism that will loosen or fail.
8. Dampers are designed for operation in temperatures ranging from -40°F (-40°C) to 212°F (100°C).
9. Leakage does not exceed 3 cfm/ft² (15.2 l/s/m²) against 1 in w.g. (0.25 kPa) static pressure differential. Tested in accordance with ANSI/AMCA Standard 500-D.
10. Dampers are custom made to required size, without blanking off free area. The blade stop is set at a fixed height and is a continuous and integral part of the top and bottom frames.
11. Dampers are available with either opposed blade action or parallel blade action.
12. Dampers are available in three install types: Installed In Duct, Flanged to Duct, and Extended Rear Flange. (See Install Type pages for details.)
13. Installation of dampers must be in accordance with TAMCO's current on-line installation guidelines. (Printed installation guidelines are provided with each damper shipment, however all technical information available on TAMCO's web site at www.tamcodampers.com supersedes information contained within printed versions.)
14. Intermediate structural support is required to resist applied pressure loads for dampers that consist of two or more sections in both height and width. (See TAMCO Aluminum Damper Installation Guidelines.)

OPTIONS FOR NP – NARROW PROFILE:

For each option listed, replace the lines above with their corresponding lines below.

ET - ELEVATED TEMPERATURE OPTION:

(This is not a UL approved product. For UL Approved Smoke Dampers refer to Series 1000 SM Submittal Data.)

3. Blade and frame seals are extruded silicone, secured in an integral slot within the aluminum extrusions. Seals are mechanically fastened to prevent shrinkage and movement over the life of the damper.
4. Bearings are composed of a bronze oilite inner bearing - fixed around a 7/16" (11.11 mm) aluminum hexagon blade pivot pin - rotating within a bronze oilite outer bearing inserted in the frame.
6. Aluminum and corrosion-resistant zinc-plated steel linkage hardware is installed in the frame side, complete with cup-point trunnion screws for a slip-proof grip. Trunnion bearing is bronze oilite.
8. Dampers are designed for operation in temperatures ranging from -40°F (-40°C) to 300°F (149°C).

MR - MOISTURE RESISTANCE OPTION:

1. Extruded aluminum (6063-T5) damper frame is not less than 0.080" (2.03 mm) in thickness. Damper frame is 4" (101.6 mm) deep x 1" (25.4 mm), with mounting flanges on both sides of frame. Damper frame has a 2" (50.8 mm) mounting flange on the rear of the damper, when ordered as Extended Rear Flange install type. Frame is assembled using stainless steel screws.
5. Adjustable 7/16" (11.11 mm) hexagonal drive rod, U-bolt fastener, and hexagonal retaining nuts are stainless steel. These provide a positive connection to blades and linkage.
6. Aluminum and stainless steel linkage hardware is installed in the frame side, complete with cup-point trunnion screws for a slip-proof grip.

SW - SALT WATER RESISTANCE OPTION:

1. Extruded aluminum (6063-T5) damper frame is not less than 0.080" (2.03 mm) in thickness. Damper frame is 4" (101.6 mm) deep x 1" (25.4 mm), with mounting flanges on both sides of frame. Damper frame has a 2" (50.8 mm) mounting flange on the rear of the damper, when ordered as Extended Rear Flange install type. Aluminum frame is clear anodized to a minimum depth of 0.7 mil (18 microns). Frame is assembled using stainless steel screws.
2. Blades are 4" (101.6 mm) deep extruded aluminum (6063-T5) air-foil profiles, clear anodized to a minimum depth of 0.7 mil (18 microns). Each blade seal extends only 0.2" (5.1 mm) beyond the frame when in the full open position. All blades are symmetrically pivoted.
3. Blade and frame seals are extruded silicone, secured in an integral slot within the aluminum extrusions. Seals are mechanically fastened to prevent shrinkage and movement over the life of the damper.
5. Adjustable 7/16" (11.11 mm) hexagonal drive rod, U-bolt fastener, and hexagonal retaining nuts are stainless steel. These provide a positive connection to blades and linkage.
6. Clear anodized aluminum and stainless steel linkage hardware is installed in the frame side, complete with cup-point trunnion screws for a slip-proof grip.

VELOCITY VS. PRESSURE DROP

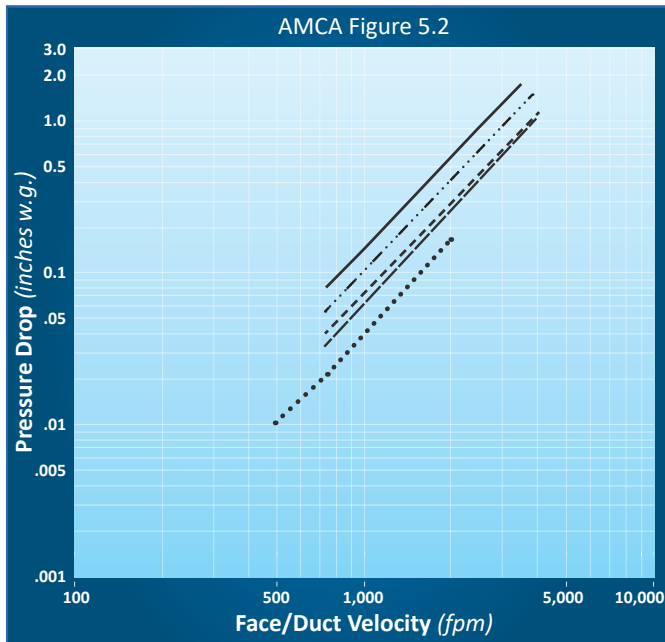

LEGEND:

12" x 12" ——— (305 mm x 305 mm)	24" x 24" - - - - (610 mm x 610 mm)	48" x 12" - · - · - (1220 mm x 305 mm)
12" x 48" ——— (305 mm x 1220 mm)	36" x 36" · · · · (915 mm x 915 mm)	

FIG. 5.2 Test damper is located at the end of 5 diameters of a duct run, exhausting into an open area. Both duct and test damper are downstream from air supply.

Pressure drop values are based on Flanged to Duct install type. Pressure drop will be greater for In Duct install type dampers.

NOTE:

- > To reduce pressure drop, use Flanged to Duct or Extended Rear Flange install types for sizes under 9 ft² (83 m²).
- > Suitable for operation in breathable air environments within stated temperature range.
- > NP dampers sized for duct openings exceeding 35³/₄" (908 mm) in height are equipped with a brace at mid-height to strengthen and maintain air leakage tolerances.

BLADE DESIGN PRESSURE LIMITATIONS

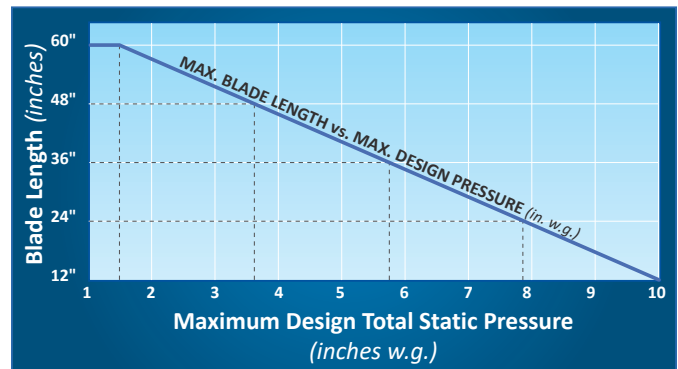

Series 1000 FB dampers NP – Narrow Profile, whose blade length exceeds the maximum design pressure, may be reconfigured to maintain a blade length compatible with the required system pressure by increasing the number of sections per damper and thereby reducing each damper section's blade length. Appropriate intermediate structural support will be required for all multiple-section damper assemblies. (Refer to line 14 of the Submittal Data and to TAMCO's Aluminum Damper Installation Guidelines.)

Example:

A single-section damper of 60" w x 36" h (1524 mm x 915 mm) at 5 in. w.g. (1.24 kPa) would need to be built in two sections of 30" w x 36" h (762 mm x 915 mm).

For additional information, refer to:

- > Series 1000, 1500 Free Area Charts
- > Face & Bypass Damper Standard Configurations
- > Aluminum Damper Torque Requirements
- > Single-Section Horizontal Jackshafts
- > Multiple-Section Horizontal Jackshafts
- > Multiple-Section Damper Jumpers
- > TAMCO Aluminum Damper Installation Guidelines

Always provide the following dimensions when ordering:

- > Opening width (A) - always parallel to blades.
- > Opening height (B) - always perpendicular to blades.
- > Face height (C2) and bypass height (C1).

INSTALLED IN DUCT TYPE ▼

- > Finished damper O.D. is $\frac{1}{2}$ " (12.7 mm) less than opening width and height dimensions.

MINIMUM SECTION SIZE:

7.5"w x 12.5"h (191 mm x 318 mm)

MAXIMUM SECTION SIZE:

25 ft² (2.3 m²)

60"w x 60"h or (1524 mm x 1524 mm) or

48"w x 75"h (1220 mm x 1905 mm)

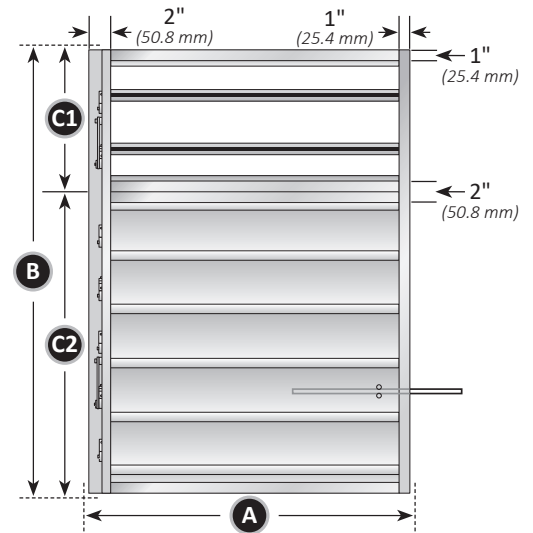

FLANGED TO DUCT TYPE ▼

- > Finished damper O.D. is 2 (50.8 mm) greater than opening width and height dimensions.
- > Linkage extends up to 1.31" (33.3 mm) beyond the outer edge of the frame for single-section wide dampers.

MINIMUM SECTION SIZE:

6"w x 10.5"h (153 mm x 267 mm)

MAXIMUM SECTION SIZE:

25 ft² (2.3 m²)

60"w x 60"h or (1524 mm x 1524 mm) or

48"w x 75"h (1220 mm x 1905 mm)

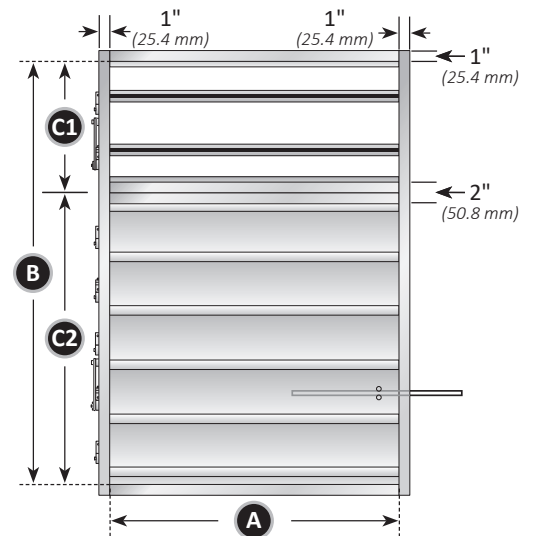

EXTENDED REAR FLANGE TYPE ▼

- > Finished damper O.D. is 4" (101.6 mm) greater than opening width and height dimensions.

MINIMUM SECTION SIZE:

6"w x 10.5"h (153 mm x 267 mm)

MAXIMUM SECTION SIZE:

25 ft² (2.3 m²)

60"w x 60"h or (1524 mm x 1524 mm) or

48"w x 75"h (1220 mm x 1905 mm)

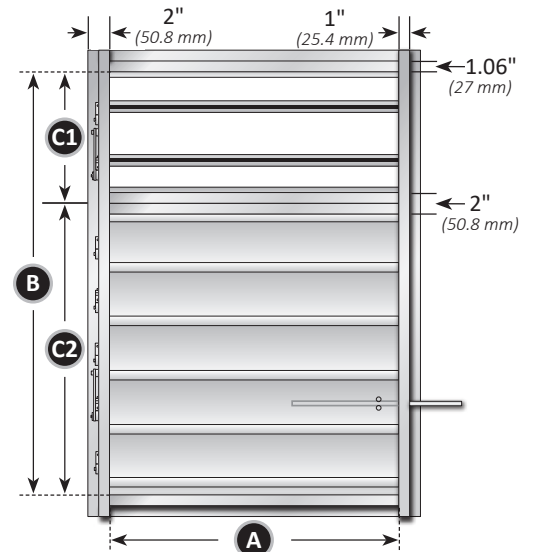

- > Extended Rear Flange install type dampers are not designed so that the front of the damper may be inserted into an opening, as the side frame members extend to the full height of the rear flange.