

In Duct or Flanged to Duct Install Types

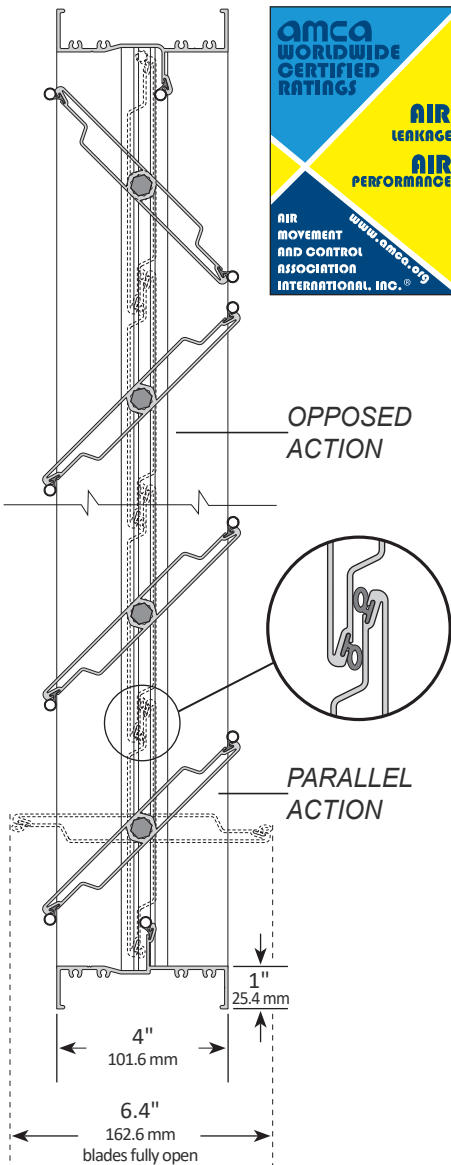

Extended Rear Flange Install Type

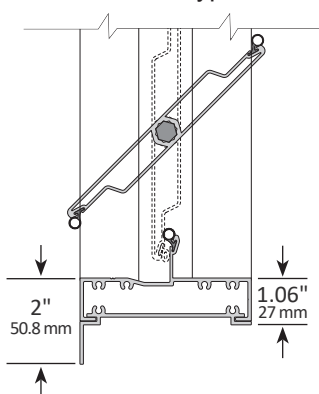

1. Extruded aluminum (6063-T5) damper frame is not less than 0.080" (2.03 mm) in thickness. Damper frame is 4" (101.6 mm) deep x 1" (25.4 mm), with mounting flanges on both sides of frame. Damper frame has a 2" (50.8 mm) mounting flange on the rear of the damper, when ordered as Extended Rear Flange install type.
2. Blades are maximum 6" (152.4 mm) deep extruded aluminum (6063-T5) air-foil profiles. All blades are symmetrically pivoted. Aluminum end caps are press fitted to blade ends in order to seal hollow interior and reduce air leakage rates.
3. Blade and frame seals are extruded silicone, secured in an integral slot within the aluminum extrusions. Seals are mechanically fastened to prevent shrinkage and movement over the life of the damper.
4. Bearings are composed of a Celcon inner bearing - fixed around a 7/16" (11.11 mm) aluminum hexagon blade pivot pin - rotating within a polycarbonate outer bearing inserted in the frame. This eliminates action between metal-to-metal or metal-to-plastic riding surfaces.
5. Adjustable 7/16" (11.11 mm) hexagonal drive rod, U-bolt fastener, and hexagonal retaining nuts are zinc-plated steel. These provide a positive connection to blades and linkage.
6. Aluminum and corrosion-resistant zinc-plated steel linkage hardware is installed in the frame side, complete with cup-point trunnion screws for a slip-proof grip.
7. Dampers are designed for operation in temperatures ranging from -40°F (-40°C) to 212°F (100°C).
8. Leakage Class 1A at 1 in. w.g. (0.25 kPa) static pressure differential. Standard air leakage data is certified under the AMCA Certified Ratings Program.
9. Dampers are custom made to required size, without blanking off free area. The blade stop is set at a fixed height and is a continuous and integral part of the top and bottom frames.
10. Dampers are available with either opposed blade action or parallel blade action.
11. Dampers are available in four install types: Installed In Duct, Flanged to Duct, Extended Rear Flange, and Square to Round Transition. (See *Install Types* pages for details.)
12. Installation of dampers must be in accordance with TAMCO's current on-line installation guidelines. (Printed installation guidelines are provided with each damper shipment, however all technical information available on TAMCO's web site at www.tamcodampers.com supersedes information contained within printed versions.)
13. Intermediate structural support is required to resist applied pressure loads for dampers that consist of two or more sections in both height and width. (See *TAMCO Aluminum Damper Installation Guidelines*.)

OPTIONS FOR SP - STANDARD PROFILE:

For each option listed, replace the lines above with their corresponding lines below.

ET - ELEVATED TEMPERATURE OPTION:

(This is not a UL/ULC approved product. For UL/ULC Approved Smoke Dampers refer to Series 1000 SM or 1000 SM-M Submittal Data.)

4. Bearings are composed of a bronze oilite inner bearing - fixed around a 7/16" (11.11 mm) aluminum hexagon blade pivot pin - rotating within a bronze oilite outer bearing inserted in the frame.
6. Aluminum and corrosion-resistant zinc-plated steel linkage hardware is installed in the frame side, complete with cup-point trunnion screws for a slip-proof grip. Trunnion bearing is bronze oilite.
7. Dampers are designed for operation in temperatures ranging from -40°F (-40°C) to 300°F (149°C).

MR - MOISTURE RESISTANCE OPTION:

1. Extruded aluminum (6063-T5) damper frame is not less than 0.080" (2.03 mm) in thickness. Damper frame is 4" (101.6 mm) deep x 1" (25.4 mm), with mounting flanges on both sides of frame. Damper frame has a 2" (50.8 mm) mounting flange on the rear of the damper, when ordered as Extended Rear Flange install type. Frame is assembled using stainless steel screws.
5. Adjustable 7/16" (11.11 mm) hexagonal drive rod, U-bolt fastener, and hexagonal retaining nuts are stainless steel. These provide a positive connection to blades and linkage.
6. Aluminum and stainless steel linkage hardware is installed in the frame side, complete with stainless steel cup-point trunnion screws for a slip-proof grip.

SW - SALT WATER RESISTANCE OPTION:

1. Extruded aluminum (6063-T5) damper frame is not less than 0.080" (2.03 mm) in thickness. Damper frame is 4" (101.6 mm) deep x 1" (25.4 mm), with mounting flanges on both sides of frame. Damper frame has a 2" (50.8 mm) mounting flange on the rear of the damper, when ordered as Extended Rear Flange install type. Aluminum frame is clear anodized to a minimum depth of 0.7 mil (18 microns). Frame is assembled using stainless steel screws.
2. Blades are maximum 6" (152.4 mm) deep extruded aluminum (6063-T5) air-foil profiles, clear anodized to a minimum depth of 0.7 mil (18 microns). All blades are symmetrically pivoted. Aluminum end caps are press fitted to blade ends in order to seal hollow interior and reduce air leakage rates. End caps are clear anodized.
5. Adjustable 7/16" (11.11 mm) hexagonal drive rod, U-bolt fastener, and hexagonal retaining nuts are stainless steel. These provide a positive connection to blades and linkage.
6. Clear anodized aluminum and stainless steel linkage hardware is installed in the frame side, complete with stainless steel cup-point trunnion screws for a slip-proof grip.

VELOCITY VS. PRESSURE DROP

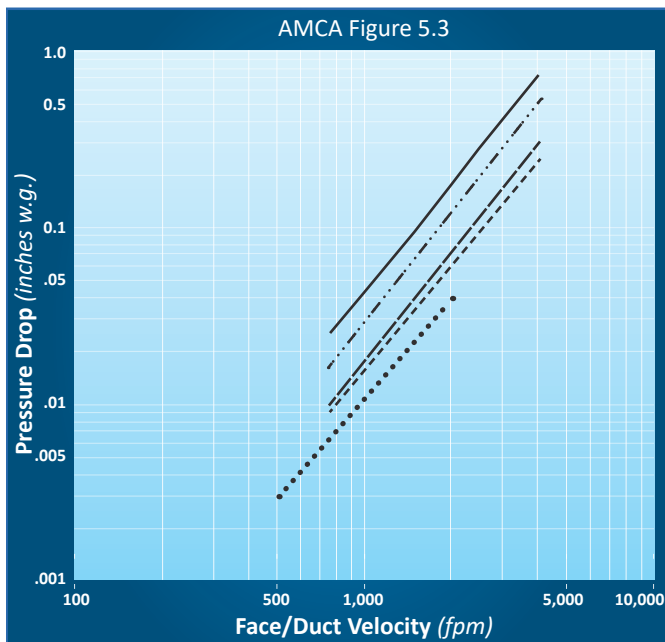

LEGEND:

12" x 12" ——— (305 mm x 305 mm)	24" x 24" - - - - (610 mm x 610 mm)	48" x 12" - · - · (1220 mm x 305 mm)
12" x 48" ——— (305 mm x 1220 mm)	36" x 36" · · · · (915 mm x 915 mm)	

BLADE DESIGN PRESSURE LIMITATIONS

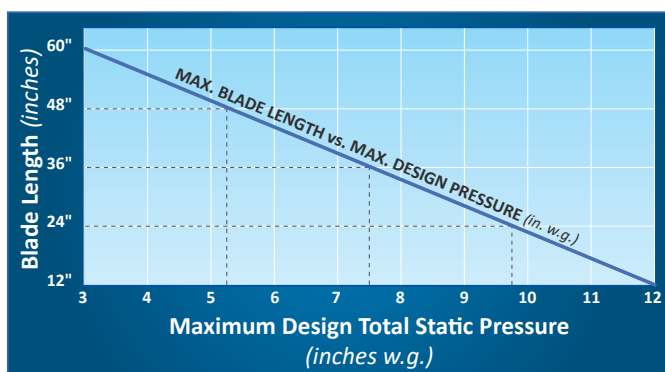

Series 1500 dampers with SP – Standard Profile, whose blade length exceeds the maximum design pressure, may be reconfigured to maintain a blade length compatible with the required system pressure by increasing the number of sections per damper and thereby reducing each damper section's blade length. Appropriate intermediate structural support will be required for all multiple-section damper assemblies. (Refer to line 13 of the Submittal Data and to TAMCO's Aluminum Damper Installation Guidelines.)

Example:

A single-section damper of 60" w x 36" h (1524 mm x 915 mm) at 5 in. w.g. (1.24 kPa) would need to be built in two sections of 30" w x 36" h (762 mm x 915 mm).

T.A. Morrison & Co. Inc. certifies that the TAMCO Series 1500 Enhanced Air-Foil Control Damper with SP – Standard Profile shown herein is licensed to bear the AMCA Seal. The ratings shown are based on tests and procedures performed in accordance with AMCA Publication 511 and comply with the requirements of the AMCA Certified Ratings Program. The AMCA Certified Ratings Seal applies to air leakage and air performance ratings.



FIG. 5.3 Test damper is fully ducted with a 5 diameter duct run upstream, and a 6 diameter duct run downstream.

Pressure drop values are based on Flanged to Duct install type. Pressure drop will be greater for In Duct install type dampers.

TAMCO LEAKAGE RATING

Damper Width inches (mm)	1 in. w.g. 0.25 kPa	4 in. w.g. 1.0 kPa	6 in. w.g. 1.5 kPa	8 in. w.g. 2.0 kPa
0.0 to 12.0 (0 to 305)	1A	1	1	1
12.1 to 36.0 (306 to 915)	1A	1	1	1
36.1 to 48.0 (916 to 1220)	1A	1	n/a	n/a
48.1 to 60.0 (1221 to 1524)	1A	1	n/a	n/a

Leakage testing was conducted in accordance with ANSI/AMCA Standard 500-D. Holding torque applied was 5.2 in-lb/ft² (6.3 N-m/m²). ANSI/AMCA Standard 500-D states that air leakage is based on operation between 32°F (0°C) and 120°F (49°C). All tests were performed with 120 in-lb (145.9 N-m/m²) of torque.

The following sizes of TAMCO Series 1500 dampers with SP – Standard Profile were tested:

12" x 48" (305 mm x 1220 mm), 36" x 36" (915 mm x 915 mm), 60" x 36" (1524 mm x 915 mm).

AMCA LEAKAGE CLASS DEFINITIONS

Pressure	MAXIMUM ALLOWABLE LEAKAGE			
	CFM/ft ² (l/s/m ²)			
Class	1 in. w.g. 0.25 kPa	4 in. w.g. 1.0 kPa	6 in. w.g. 1.5 kPa	8 in. w.g. 2.0 kPa
1A	3 (15.2)	n/a	n/a	n/a
1	4 (20.3)	8 (40.6)	9.8 (49.8)	11.3 (57.4)
2	10 (50.8)	20 (102)	24.5 (125)	28.3 (144)
3	40 (203)	80 (406)	98 (498)	113 (574)

***NOTE:** TAMCO Leakage Class Rating is not provided for dampers measuring more than 36" (915 mm) wide at 6 in. w.g. (1.5 kPa) and at 8 in. w.g. (2.0 kPa), as the recommended blade length is exceeded at these static pressures. (Refer to the Blade Design Pressure Limitations Chart.)

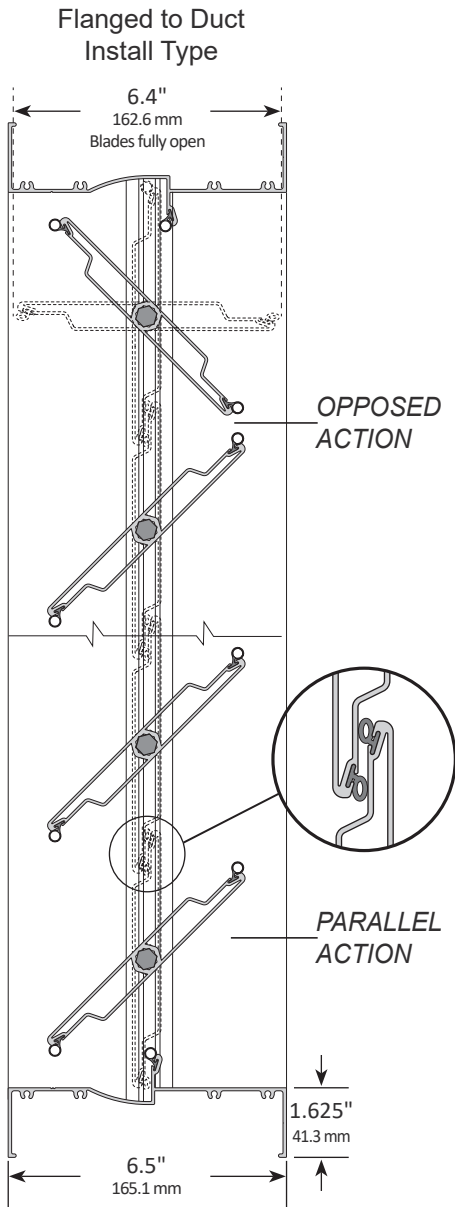

1. Extruded aluminum (6063-T5) damper frame is not less than 0.080" (2.03 mm) in thickness. Damper frame is 6.5" (165.1 mm) deep x 1.625" (41.3 mm), with mounting flanges on both sides of frame.
2. Blades are maximum 6" (152.4 mm) deep extruded aluminum (6063-T5) air-foil profiles. All blades are symmetrically pivoted. Aluminum end caps are press fitted to blade ends in order to seal hollow interior and reduce air leakage rates.
3. Blade and frame seals are extruded silicone, secured in an integral slot within the aluminum extrusions. Seals are mechanically fastened to prevent shrinkage and movement over the life of the damper.
4. Bearings are composed of a Celcon inner bearing - fixed around a 7/16" (11.11 mm) aluminum hexagon blade pivot pin - rotating within a polycarbonate outer bearing inserted in the frame. This eliminates action between metal-to-metal or metal-to-plastic riding surfaces.
5. Adjustable 7/16" (11.11 mm) hexagonal drive rod, U-bolt fastener, and hexagonal retaining nuts are zinc-plated steel. These provide a positive connection to blades and linkage.
6. Aluminum and corrosion-resistant zinc-plated steel linkage hardware is installed in the frame side, complete with cup-point trunnion screws for a slip-proof grip.
7. Dampers are designed for operation in temperatures ranging from -40°F (-40°C) to 212°F (100°C).
8. Leakage rate through a 48" x 36" (1220 mm x 915 mm) does not exceed 1.2 cfm/ft² (6.1 l/s/m²) against 1 in. w.g. (0.25 kPa) differential static pressure. Tested in accordance with ANSI/AMCA Standard 500 D.
9. Dampers are custom made to required size, without blanking off free area. The blade stop is set at a fixed height and is a continuous and integral part of the top and bottom frames.
10. Dampers are available with either opposed blade action or parallel blade action.
11. Dampers are available as Flanged to Duct Install Type only. (See Install Types pages for details.)
12. Installation of dampers must be in accordance with TAMCO's current on-line installation guidelines. (Printed installation guidelines are provided with each damper shipment, however all technical information available on TAMCO's web site at www.tamcodampers.com supersedes information contained within printed versions.)
13. Intermediate structural support is required to resist applied pressure loads for dampers that consist of two or more sections in both height and width. (See TAMCO Aluminum Damper Installation Guidelines.)

OPTIONS FOR WP – WIDE PROFILE:

For each option listed, replace the lines above with their corresponding lines below.

ET - ELEVATED TEMPERATURE OPTION:

(This is not a UL/ULC approved product. For UL/ULC Approved Smoke Dampers refer to Series 1000 SM or 1000 SM-M Submittal Data.)

4. Bearings are composed of a bronze oilite inner bearing - fixed around a 7/16" (11.11 mm) aluminum hexagon blade pivot pin - rotating within a bronze oilite outer bearing inserted in the frame.
6. Aluminum and corrosion-resistant zinc-plated steel linkage hardware is installed in the frame side, complete with cup-point trunnion screws for a slip-proof grip. Trunnion bearing is bronze oilite.
7. Dampers are designed for operation in temperatures ranging from -40°F (-40°C) to 300°F (149°C).

MR - MOISTURE RESISTANCE OPTION:

1. Extruded aluminum (6063-T5) damper frame is not less than 0.080" (2.03 mm) in thickness. Damper frame is 6.5" (165.1 mm) deep x 1.625" (41.3 mm), with mounting flanges on both sides of frame. Frame is assembled using stainless steel screws.
5. Adjustable 7/16" (11.11 mm) hexagonal drive rod, U-bolt fastener, and hexagonal retaining nuts are stainless steel. These provide a positive connection to blades and linkage.
6. Aluminum and stainless steel linkage hardware is installed in the frame side, complete with stainless steel cup-point trunnion screws for a slip-proof grip.

SW - SALT WATER RESISTANCE OPTION:

1. Extruded aluminum (6063-T5) damper frame is not less than 0.080" (2.03 mm) in thickness. Damper frame is 6.5" (165.1 mm) deep x 1.625" (41.3 mm), with mounting flanges on both sides of frame. Aluminum frame is clear anodized to a minimum depth of 0.7 mil (18 microns). Frame is assembled using stainless steel screws.
2. Blades are maximum 6" (152.4 mm) deep extruded aluminum (6063-T5) air-foil profiles, clear anodized to a minimum depth of 0.7 mil (18 microns). All blades are symmetrically pivoted. Aluminum end caps are press fitted to blade ends in order to seal hollow interior and reduce air leakage rates. End caps are clear anodized.
5. Adjustable 7/16" (11.11 mm) hexagonal drive rod, U-bolt fastener, and hexagonal retaining nuts are stainless steel. These provide a positive connection to blades and linkage.
6. Clear anodized aluminum and stainless steel linkage hardware is installed in the frame side, complete with stainless steel cup-point trunnion screws for a slip-proof grip.

VELOCITY VS. PRESSURE DROP

SIZE inches	VELOCITY fpm	PRESSURE DROP (inches w.g.)					
		AMCA Fig. 5.4 (Intake)			AMCA Fig. 5.5 (Exhaust)		
		DAMPER & SYSTEM	SYSTEM ONLY	DAMPER ONLY	DAMPER & SYSTEM	SYSTEM ONLY	DAMPER ONLY
12 X 48	1000	0.157	0.166	-0.008	0.143	0.155	-0.012
	2000	0.625	0.654	-0.029	0.596	0.638	-0.042
	3000	1.388	1.482	-0.094	1.332	1.458	-0.126
24 X 24	1000	0.154	0.164	-0.010	0.155	0.159	-0.004
	2000	0.615	0.658	-0.043	0.650	0.653	-0.003
	3000	1.408	1.478	-0.069	1.459	1.471	-0.012
36 X 36	1000	0.157	0.172	-0.015	0.152	0.157	-0.005
	2000	0.628	0.685	-0.057	0.614	0.634	-0.020
	3000	1.401	1.547	-0.146	1.382	1.427	-0.045
48 X 12	1000	0.140	0.166	-0.025	0.133	0.155	-0.023
	2000	0.547	0.654	-0.107	0.546	0.638	-0.092
	3000	1.211	1.482	-0.271	1.233	1.458	-0.225
48 X 48	1000	0.163	0.169	-0.006	0.146	0.155	-0.009
	2000	0.646	0.673	-0.027	0.588	0.613	-0.025
	3000	1.461	1.520	-0.058	1.296	1.394	-0.098

FIG. 5.4 Test damper is located at the entrance of a plenum.

FIG. 5.5 Test damper is located at the exit of a plenum.

Air Performance testing was conducted in accordance with ANSI/AMCA Standard 500-D.

Pressure drop values are based on Flanged to Duct install type. Pressure drop will be greater for In Duct install type dampers.

The table above shows AMCA Figure 5.4 (intake) and Figure 5.5 (exhaust) pressure drop test results for a range of opening sizes. Pressure drop tests were conducted for each of the following:

- > System Only. (No damper installed in the opening.)
- > Damper & System. (TAMCO damper installed in the opening.)

The third column (Damper Only) under each AMCA Figure shows what effect the TAMCO WP dampers have on the airflow through each opening size. This is calculated by subtracting the Damper and System results from the System Only results. The pressure drop for WP TAMCO dampers is less than the pressure drop of the opening alone.

BLADE DESIGN PRESSURE LIMITATIONS

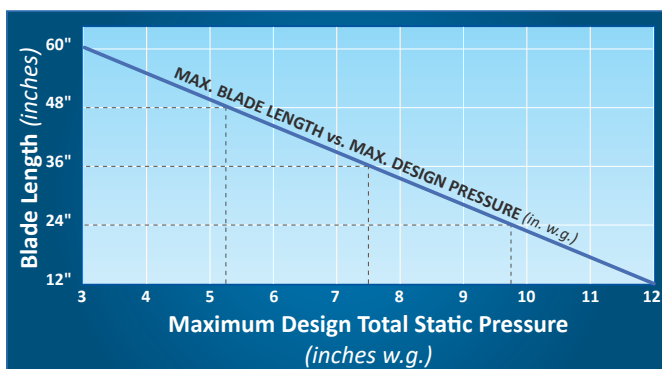

Series 1500 dampers with WP – Wide Profile, whose blade length exceeds the maximum design pressure, may be reconfigured to maintain a blade length compatible with the required system pressure by increasing the number of sections per damper and thereby reducing each damper section's blade length. Appropriate intermediate structural support will be required for all multiple-section damper assemblies. (Refer to line 13 of the Submittal Data and to TAMCO's Aluminum Damper Installation Guidelines.)

Example:

A single-section damper of 60" w x 36" h (1524 mm x 915 mm) at 5 in. w.g. (1.24 kPa) would need to be built in two sections of 30" w x 36" h (762 mm x 915 mm).

Enhanced Air-Foil Control Damper

- > Always provide opening width and height dimensions, when ordering.
- > Width dimension is always parallel to blades.
- > Height dimension is always perpendicular to blades.

INSTALLED IN DUCT TYPE ▼

- > Applies to SP Profiles only. Not available for WP Profile.
- > Finished damper O.D. is $\frac{1}{2}$ " (12.7 mm) less than opening width and height dimensions.

MINIMUM SECTION SIZE:

6½" w x 6¾" h (166 mm x 172 mm)

MAXIMUM SECTION SIZE:

25 ft² (2.3 m²)

60" w x 60" h or (1524 mm x 1524 mm) or

48" w x 75" h (1220 mm x 1905 mm)

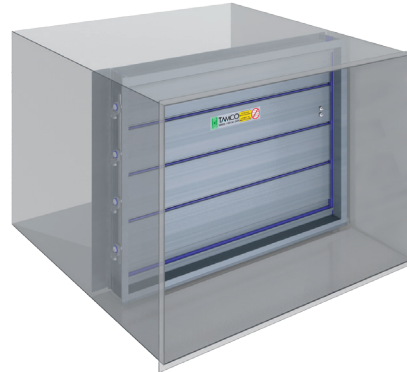

FLANGED TO DUCT TYPE ▼

- > For SP Profile, finished damper O.D. is 2" (50.8 mm) greater than opening width and height dimensions.
- > For WP Profile, finished damper O.D. is 3.25" (82.6 mm) greater than opening width and height dimensions.

MINIMUM SECTION SIZE:

4½" w x 4¾" h (115 mm x 108 mm)

MAXIMUM SECTION SIZE:

25 ft² (2.3 m²)

60" w x 60" h or (1524 mm x 1524 mm) or

48" w x 75" h (1220 mm x 1905 mm)

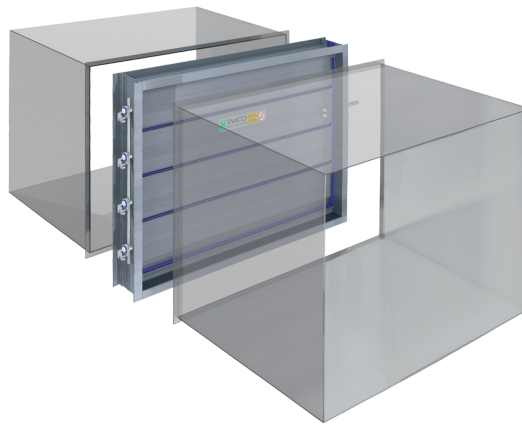

EXTENDED REAR FLANGE TYPE ▼

- > Applies to SP Profiles only. Not available for WP Profile.
- > Finished damper O.D. is 4" (101.6 mm) greater than opening width and height dimensions.

MINIMUM SECTION SIZE:

4½" w x 4¾" h (115 mm x 108 mm)

MAXIMUM SECTION SIZE:

25 ft² (2.3 m²)

60" w x 60" h or (1524 mm x 1524 mm) or

48" w x 75" h (1220 mm x 1905 mm)

- > Extended Rear Flange install type dampers are not designed so that the front of the damper may be inserted into an opening, as the side frame members extend to the full height of the rear flange.



SQUARE TO ROUND TRANSITION ▼

- > Applies to SP Profile only. Not available for WP Profile.
- > Always provide duct diameter dimension when ordering.
- > If using TAMCO Connect software to submit orders, enter duct diameter dimension in both the width and height fields.
- > Transition pieces are a minimum of 18 ga. galvanized steel when Series 1500 dampers are ordered with no option or with the ET Option.
- > Transition pieces are 304 stainless steel, when Series 1500 dampers are ordered with the MR or SW Options.
- > Transition pieces and damper are sealed together.
- > Dampers are built 4" (102 mm) larger than specified duct diameter. (*Dampers are fabricated square.*)
- > Finished transition diameter is $\frac{1}{4}$ " (6.35 mm) less than specified duct diameter, providing clearance for mating duct which slides over round transition. This ensures free movement of damper blades.

MINIMUM DUCT DIAMETER:	
4"	(102 mm)
MAXIMUM DUCT DIAMETER:	
58"	(1474 mm)
MAXIMUM SECTION SIZE:	
25 ft ²	(2.3 m ²)
MAXIMUM FINISHED OD:	
62" w x 62" h	(1575 mm x 1575 mm)

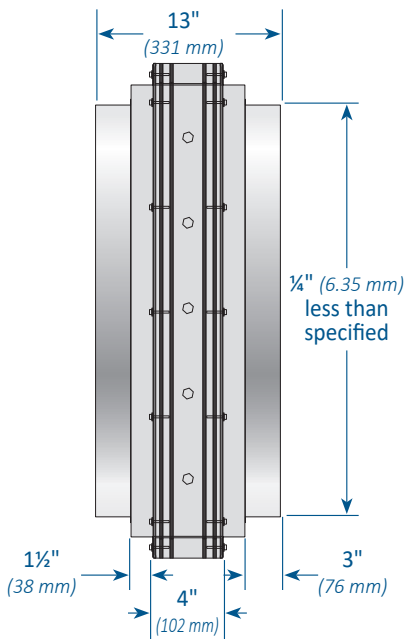
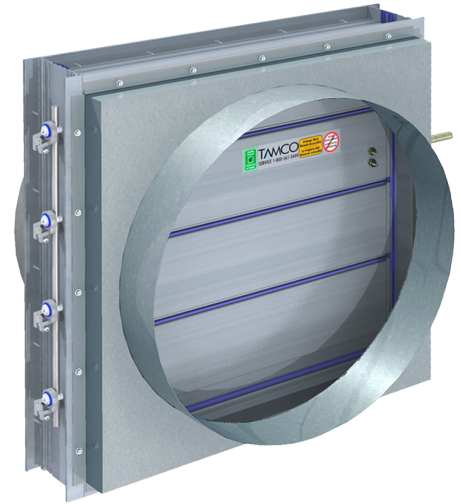

Linkage extends up to $1\frac{5}{16}$ " (33.3 mm) beyond the outer edge of the transition.

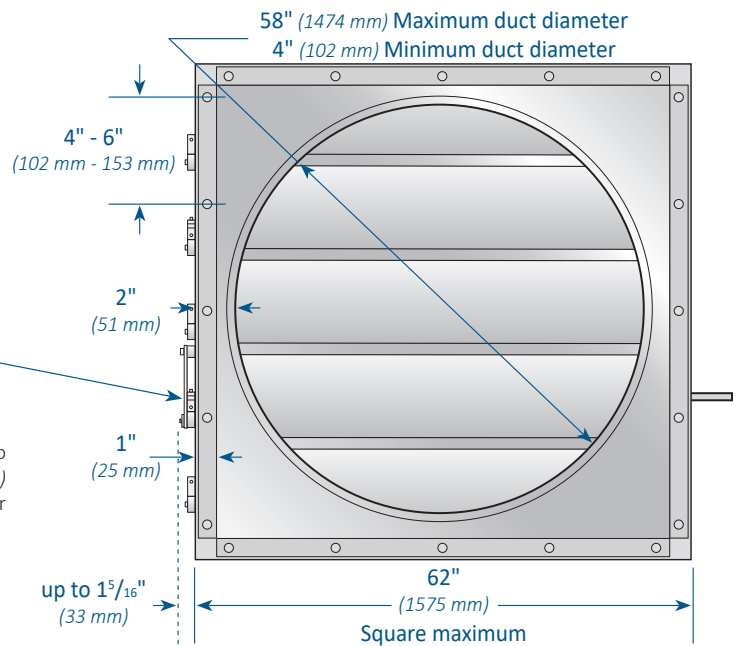

NOTE:

- > To reduce pressure drop, use Flanged to Duct or Extended Rear Flange install types for sizes under 9 ft² (.83 m²).
- > Suitable for operation in breathable air environments within stated temperature range.
- > SP and WP dampers sized for duct openings exceeding 37 $\frac{3}{4}$ " (959 mm) in height are equipped with a brace at mid-height to strengthen and maintain air leakage tolerances.

For additional information, refer to:

- > Series 1000, 1500 Free Area Charts
- > Aluminum Damper Standard Configurations
- > Aluminum Damper Torque Requirements
- > Single-Section Horizontal Jackshafts
- > Multiple-Section Horizontal Jackshafts
- > Configurations Using Vertical Jackshafts
- > Multiple-Section Damper Jumpers
- > TAMCO Aluminum Damper Installation Guidelines