

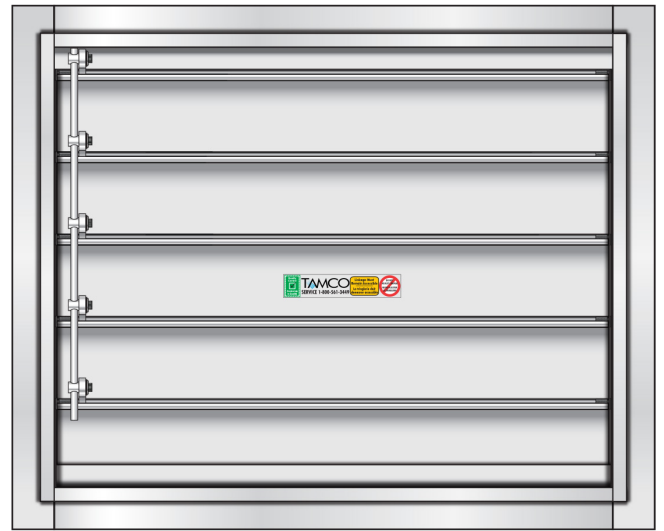

FRONT VIEW



BACK VIEW

GENERAL INSTALLATION NOTES ▼

- > Backdraft dampers must be kept clean and dry. Store indoors to protect from dirt, dust and weather. Do not store at temperatures in excess of 100°F (38°C).
- > Do not stack backdraft dampers on top of or against each other.
- > Backdraft dampers are to be handled and lifted by the frames only. Do not use the blades or linkage to lift backdraft dampers.
- > Do not drop, drag or twist.
- > Multiple-section assemblies will require sufficient people and appropriate rigging to lift units safely and without causing damage.
- > Ensure that the opening or duct work is free of any obstructions and is adequately supported, so that damper operation is not adversely affected.
- > The system must support the damper. The damper cannot support the system. Do not use the damper to square up duct. The opening must be plumb, straight, level, square, and sized correctly for the backdraft damper.
- > The backdraft damper must not be twisted, compressed or stretched to fit the opening. Once installed, the blades must be free to move without binding. Use shims between the damper frame and the opening to prevent distortion or stretching of the backdraft damper.
- > When installing fasteners (provided by others), they should be located so as not to interfere with linkage parts or blade operation.
- > Consult engineering plans prior to installation to confirm airflow direction.
- > TAMCO recommends that backdraft dampers be installed at a minimum distance of one (1) fan diameter away from the fan, for custom air handler exhaust applications. AMCA 200 and AMCA 201 recommend a distance of one (1) duct diameter for each 1000 fpm in order to achieve uniform air at the backdraft damper. The type of fan and distance allowed between the fan and the damper will determine the air velocity profile the backdraft damper will be subjected to.
- > When backdraft dampers are installed in the vertical plane, blades must always be horizontal.
- > Series 7000, 7000 WT, and 7000 CW Backdraft Dampers can be installed in the vertical plane (Airflow Horizontal), or in the horizontal plane (Airflow Up).
- > Only Series 7000 CW Counterweighted Backdraft Dampers can be installed in the horizontal plane with Airflow Down.

TAMCO's all-aluminum backdraft dampers are constructed with maintenance-free bearing and linkage components.

Caution: Never use any lubricants, such as grease or silicone, on TAMCO backdraft dampers.

In applications where the humidity level is unusually elevated, or where there are extremely high levels of dust and dirt particles, TAMCO recommends that the damper linkage and bearing system should be cleaned once a year. This can be done by blowing away dust using compressed air. If needed, a domestic-strength steam cleaner can be used to loosen dirt, which can then be blown out with compressed air, along with any remaining water droplets

Note that all technical information available on TAMCO's website at www.tamcodampers.com supersedes and takes precedence over all information contained within the printed catalog.

CALL TAMCO CUSTOMER SERVICE WITH ANY QUESTIONS CONCERNING TAMCO BACKDRAFT DAMPERS

1-800-561-3449

**DO NOT ADJUST LINKAGE MECHANISM. IF PROBLEM STILL EXISTS
AFTER VERIFICATION AND CORRECT ACTION,
CALL TAMCO CUSTOMER SERVICE.**

- ✓ Before installing, inspect backdraft damper for possible damage caused in shipping, and that it has not been racked or twisted. Measure the damper from corner to corner to verify that it is square.
- ✓ If minor damage has occurred to frame corners or flanges, correct by bending or hammering back into position. Ensure correct realignment of repair, as bent or twisted frames might not mate properly with mounting angles, or additional backdraft damper sections.
- ✓ Do not install backdraft damper if damage is more than superficial.
- ✓ If uncertain as to extent of damage, or if damper does not operate correctly, call TAMCO Customer Service at 1-800-561-3449.
- ✓ Compare items listed on packing list with materials received to ensure all parts of the shipment are accounted for.

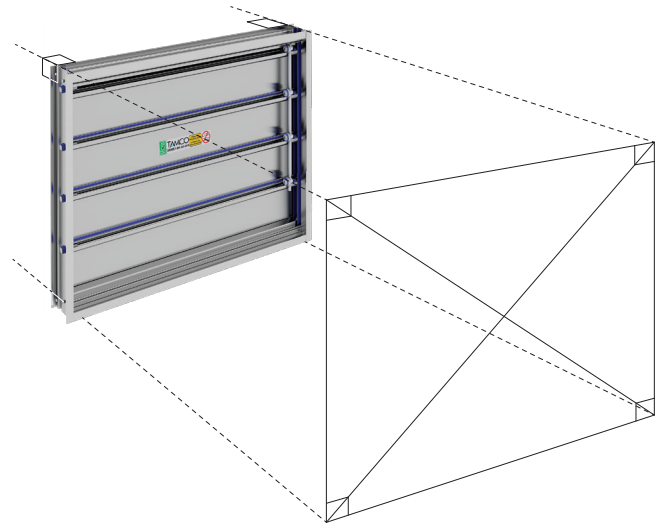

INSTALLATION OF DAMPER TYPES ▼

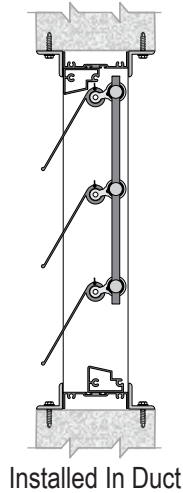

INSTALLED IN DUCT TYPE

- > Verify that backdraft damper is square.
- > Backdraft damper is manufactured so that finished O.D. is $\frac{1}{4}$ " (6.4 mm) smaller than opening width and height dimensions.
- > Ensure that duct is square and/or large enough to allow backdraft damper to be installed square.
- > Insert entire backdraft damper into opening. Bottom of damper frame must sit flat on floor of duct to prevent twisting, sagging, or bowing.
- > Install single-section units using mounting clips or angles. Arrange clips (angles) snugly against the perimeters of the front and back damper frames, securing clips (angles) to duct work. (TAMCO recommends that the clips (angles) should be fastened to the duct work only, and not to the backdraft damper. This will prevent the fasteners from binding or twisting the damper.)
- > If access to both sides of the backdraft damper is limited, install clips (angles) to the duct work around the perimeter of either the front or the back frames. Then secure the clips (angles) to the damper frame.
- > TAMCO recommends that a minimum of two fasteners per frame length be used (top, bottom, left and right). Fasteners should be spaced at 12" (305 mm) to 15" (381 mm) oc.
- > Caulk all connections/joints between damper frame and duct to minimize installation leakage.

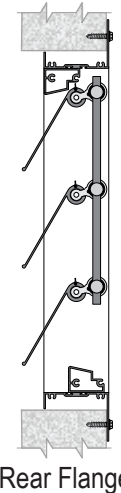
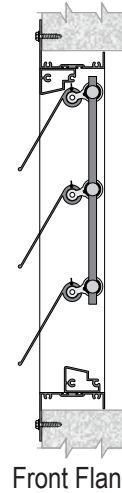

FRONT OR REAR FLANGE INSTALL TYPES

- > Verify that backdraft damper is square.
- > Inserted portion of backdraft damper is approximately $\frac{1}{4}$ " (6.4 mm) smaller than specified duct size.
- > Ensure that the substrate the backdraft damper will be attached to is flat and level.
- > Pre-drill fastener holes in the backdraft damper flange, before placing over opening, to reduce twisting and binding.
- > Place single-section units directly on wall or floor. Secure backdraft damper's flange to substrate using appropriate fasteners.
- > TAMCO recommends that a minimum of two fasteners per frame length be used (top, bottom, left and right). Fasteners should be spaced at 12" (305 mm) to 15" (381 mm) oc.
- > Do not overtighten fasteners to substrate. Doing so may damage or twist the backdraft damper, which will increase air leakage.
- > Caulk all connections/joints between damper frame and duct to minimize installation leakage.

MULTI-SECTION BACKDRAFT DAMPER ASSEMBLIES ▼

- > Sections may be installed in or over its own field-supplied support structure individually, or they may be field-assembled prior to installation.
- > If field-assembly is required before installation, lay dampers on a flat surface (such as a floor) with TAMCO label facing upwards to assemble sections.

Note: T-Bars provided by TAMCO to interconnect damper sections, are for alignment purposes only and may not be considered as structural supports.

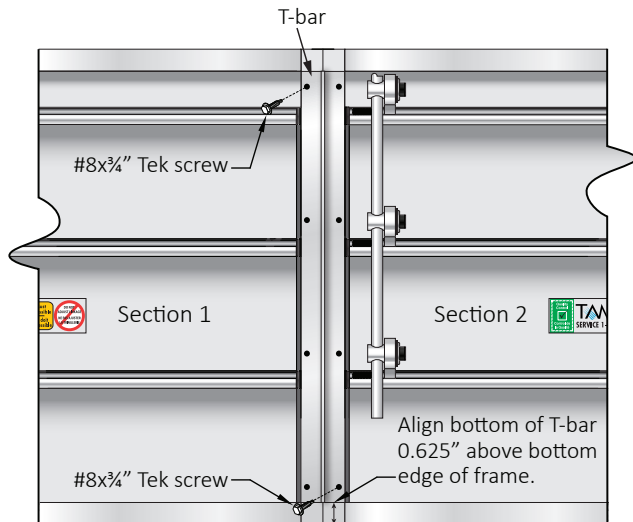

STRUCTURAL SUPPORT REQUIREMENTS ▼

- > Field-supplied, intermediate structural support is required to resist applied velocity and pressure loads for backdraft dampers that are two or more sections high or wide.
- > Angle bracing installed at multi-section joints will prevent bowing and twisting of backdraft damper units.
- > TAMCO Series 7000 Backdraft Dampers weigh approximately 2 lbs/ft² (9.76 kg/m²). TAMCO Series 7000 WT and 7000 CW Backdraft Dampers weigh approximately 3 lbs/ft² (14.65 kg/m²).

TWO OR MORE SECTIONS WIDE

1. Ensure that all backdraft damper sections are straight, even, and aligned with each other.
2. T-bars are to be installed on the back (sticker) side of the damper.
3. To pierce alignment holes in the damper frames where the two section meet, apply the T-bar extrusion so that it sits 0.625" (16 mm) above the bottom edge of the vertical frames where backdraft damper sections meet. Verify that the T-bar sits flat against each damper frame and is flush to the side of each frame member, so it does not interfere with blade operation.
4. Secure the T-bar to Section 2 through the lowest right hole in the T-bar, using a #8x³/₄" Tek screw. Next secure the T-bar to the Section 1 through the uppermost left hole in the T-bar, using a #8x³/₄" Tek screw. This will ensure proper alignment of two horizontally joining sections, once the T-bar is fully installed.
5. If leakage is a concern, now remove the T-Bar and apply a bead of silicone caulk along the joint where the two damper frames meet. Then, replace the T-Bar and the two screws, using the alignment holes made in Step 3.
6. Finish securing the T-Bar to the damper frames by inserting #8x³/₄" Tek screws into the rest of the holes located on the T-Bar.
7. Repeat Steps 1-6 for any additional horizontally connected sections.

MULTIPLE SECTIONS WIDE BY MULTIPLE SECTIONS HIGH

1. Ensure that all backdraft damper sections are straight, even, and aligned with each other.
2. Install the bottommost sections of the backdraft damper assembly first.
3. T-bars are to be installed on the back (sticker) side of the damper. Each T-bar will be shorter than the height of a single section. This is to ensure that a full T-bar piece can be centered across the intersection where four damper sections meet.
4. To pierce alignment holes in the damper frames where the two section meet, apply the T-bar extrusion so that it sits 0.625" (16 mm) above the bottommost edge of the vertical frames where backdraft damper sections meet. Verify that the T-bar sits flat against each damper frame and is flush to the side of each frame member, so it does not interfere with blade operation.
5. Secure the T-bar to Section 2 through the lowest right hole in the T-bar, using a #8x³/₄" Tek screw. Next secure the T-bar to the Section 1 through the uppermost left hole in the T-bar, using a #8x³/₄" Tek screw. This will ensure proper alignment of two horizontally joining sections, once the T-bar is fully installed.
6. If leakage is a concern, now remove the T-Bar and apply a bead of silicone caulk along the joint where the two damper frames meet. Then, replace the T-Bar and the two screws, using the alignment holes made in Step 4.
7. Finish securing the T-Bar to the damper frames by inserting #8x³/₄" Tek screws into the rest of the holes located on the T-Bar.
8. Repeat Steps 1-7 for any additional horizontally connected sections.
9. Install the next row of dampers. Stack the next T-Bar directly above the previously fastened one, and repeat steps 1-8 for all subsequent backdraft damper sections, until the full height of the damper is connected with T-Bars.

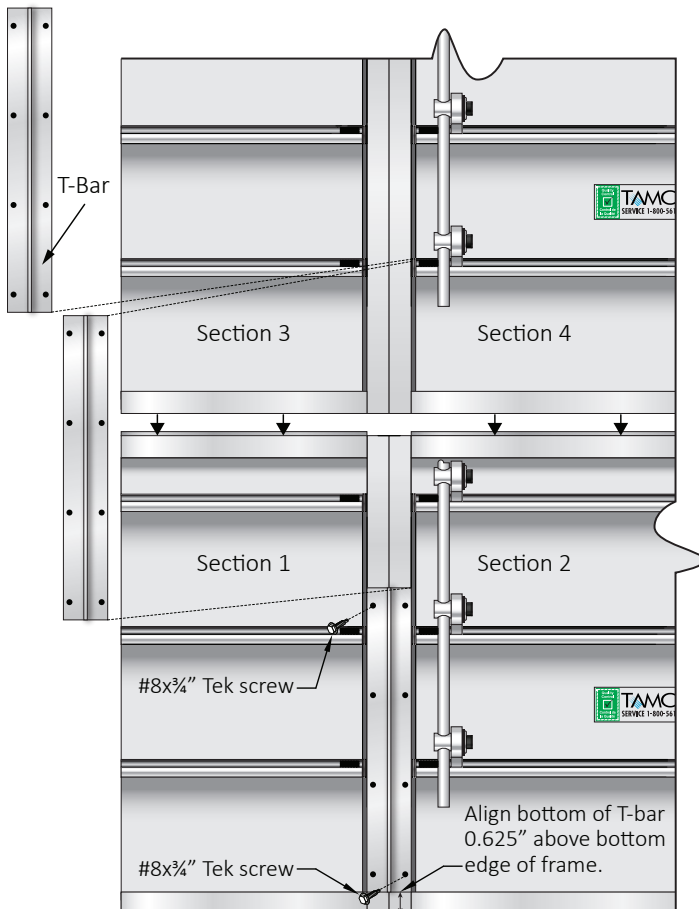

SERIES 7000 WT ▼

- > Series 7000 WT Weighted Backdraft Dampers have a round, adjustable weight and a threaded post secured to the center of each blade. A zert nut on the back of the blade is used to lock the threaded post in place.
- > Each cylindrical, steel weight measures 1¼" (32 mm) in diameter.
- > Weights are supplied, so that the required resistance to the opening of the blade against airflow can be achieved.
- > The cylinder can be adjusted away from or towards the blade, as far as the threaded post will allow.
- > Moving the weight away from the blade will increase the amount of additional pressure and airflow required to open the backdraft damper blades.
- > Moving the weight closer to the blade will decrease the amount of additional air pressure and airflow required to open the backdraft damper blades.
- > Additional weights may be added to increase the desired pressure build-up before the backdraft damper begins to open.
- > Adjust weight placement until desired pressure build-up is achieved. *(Several re-adjustments may be necessary for desired operation.)*
- > Once adjustment is completed, tighten the weight locking nut to prevent weight from moving out of position.

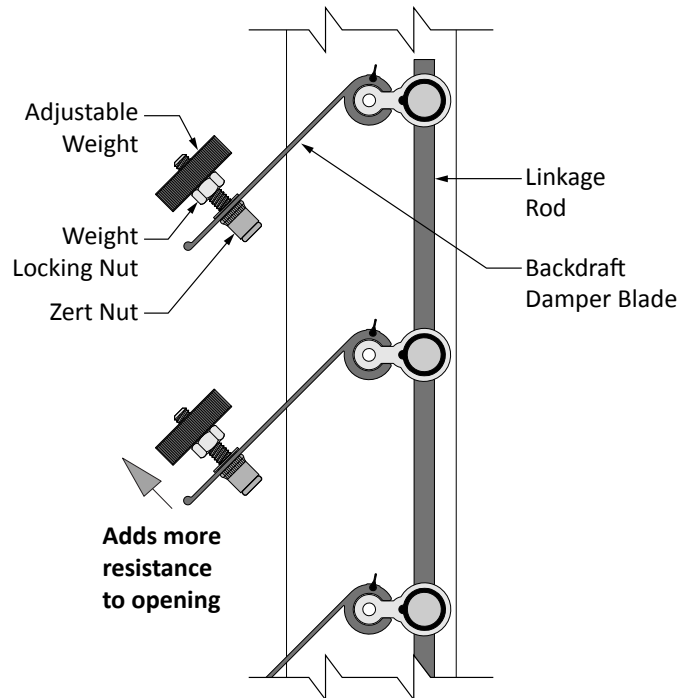

SERIES 7000 CW ▼

- > Series 7000 CW Counterweighted Backdraft Dampers have an adjustable ¾" wide (19 mm) aluminum, counterweight bar attached to the back of the blades *(with the exception of the top blade)*.
- > The aluminum bar bracket is centered along the length of the blade. This is designed to apply even pressure across each blade. Do not move the bar bracket away from the factory-aligned center of the blade.
- > Counterweights can be set to relieve air pressure differentials less than .01 in. w.g. (3 Pa).
- > To accelerate blade opening, move the aluminum counterweight bar further away from the blade.
- > To delay blade opening, move the aluminum counterweight bar closer to the blade.
- > To move the aluminum counterweight bar, first loosen the two socket head cap screws with a ⅜" (4.8 mm) Allen/Hex wrench. Do not remove the screws. *(The socket head cap screws secure the aluminum counterweight bar in place, through the washer and the aluminum bar bracket.)*
- > Slide the aluminum counterweight bar in the direction required to achieve desired blade operation. The counterweight bars should be adjusted to the same location on each blade, to ensure that even pressure is applied across the entire backdraft damper. *(Several re-adjustments may be necessary. Keep in mind that depending on external conditions and damper size, moving the aluminum bar to the furthest point away from the blade might prevent the backdraft damper from closing.)*
- > Once adjustment is completed, re-tighten socket head cap screws.

